

Ethernet system for the acquisition of dynamic signals

8 or 2 SE/diff. inputs, 24-bit, simultaneous acquisition

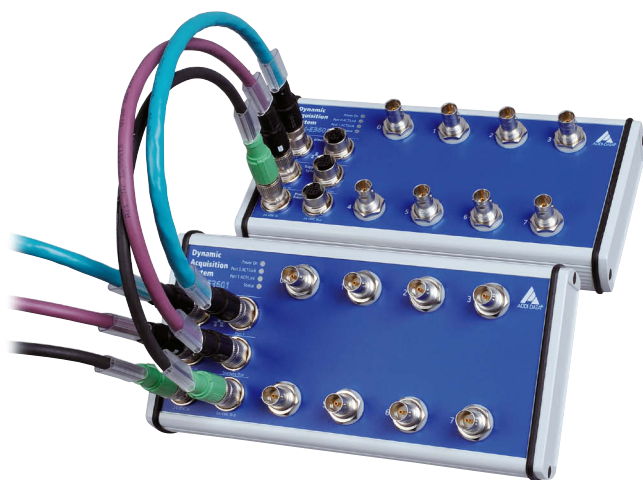

MSX-E3601 / MSX-E3601-2

8 or 2 SE/diff. inputs, 24-bit

Simultaneous acquisition

8 or 2 current sources for ICP® or IEPE sensors

Onboard calibration

24 V digital trigger input

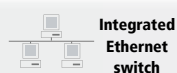

Integrated Ethernet switch



*Operating temperature



ARM®9 Technology

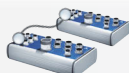

Cascadable, can be synchronised in the μ s range



on request



DatabaseConnect see page 114



More information on www.addi-data.com

Features

- 24 V digital trigger input
- ARM®9 32-bit processor
- 64 MB onboard SDRAM for storing data
- Robust standardized metal housing
- Power Save Mode: Reduced power consumption when no acquisition runs

Analog inputs

- 8 or 2 SE or diff. inputs, 24-bit, AC/DC coupling
- One A/D converter per channel: simultaneous acquisition on all analog inputs
- Sampling rate up to 128 kHz
- Antialiasing filter
- BNC female connector:
 - inner conductor for positive input
 - outer conductor for negative input (diff) or GND (SE)
- Gain x1, x10, x100

Current sources

- 8 or 2 current sources for the direct connection of ICP® sensors (integrated circuit piezoelectric) or IEPE sensors (integrated electronics piezoelectric)
- 4 mA typ., 24 V max.

Safety features

- Status LEDs for fast error diagnostics
- Optical isolation
- Input filters
- Overvoltage protection ± 40 V
- Internal temperature monitoring

Interfaces

- Fast 24 V trigger input
- Ethernet switch with 2 ports
- Synchronisation/trigger In/Out
- Line in for 24 V supply and cascading

Communication interfaces

- Web server (configuration and monitoring)
- Command server SOAP for transferring commands
- Data server (TCP/IP or UDP socket) for sending acquisition data
- Event server (TCP/IP socket) for sending system events (Diagnostics such as temperature, short-circuits ...)

Synchronisation/time stamp

Time stamp

Several MSX-E systems can be synchronised with one another in the μ s range through a synchro connection. This allows to start a synchronous data acquisition, to generate trigger events and to synchronise the time on several MSX-E systems. Furthermore, the systems have a time stamp that logs the point in time at which the data was acquired by the system.

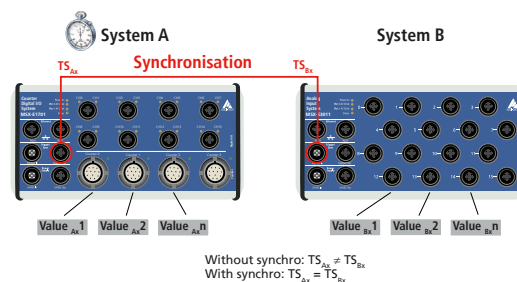

The combination of synchronisation and time stamp (TS) allows the clear allocation of signals that were captured by several systems.

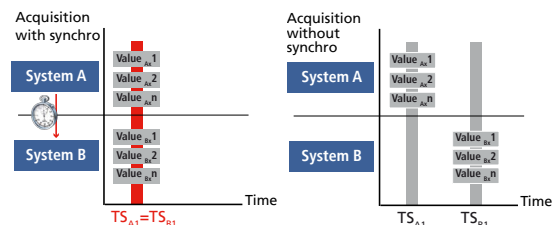

MSX-E3601-2





Acquisition modes

Sequence mode

In sequence mode, a list of channels is acquired. Thereby, the single measurement rows are stored one after another. The client receives the acquired values asynchronously to the acquisition through a socket connection. In the sequence mode, the measurement values are read in chronological order, this means the oldest values are read first. The acquisition can be effected continuously, with or without delay or in combination with a hardware or synchro trigger.

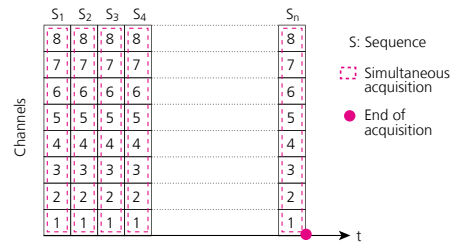

Acquisition triggered through trigger or synchro input

Example: A measurement process is to be started through an external trigger impulse. For each trigger, 10 sequences are to be acquired. After the acquisition of the 10 sequences they are to be sent to the client.



Reading data from a MSX-E system

MSX-E systems are multi-client capable, this means several clients (e. g. PC, server, PLC, ...) can read the measurement values of one MSX-E system at the same time. For this, each client establishes a socket connection to the data server of the MSX-E system (port 8989). As soon as the measurement values are available on the data server, the MSX-E system transfers them to the clients.

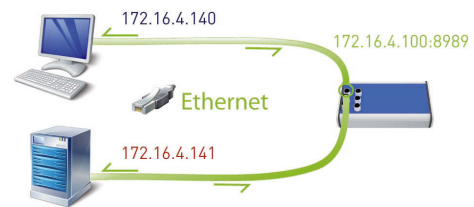

Onboard programming / stand-alone operation

Development mode

With the Development mode of the MSX-E systems you can customise your measurement, control and regulation applications to fit your requirements. The programs run directly on the MSX-E systems, which has two advantages: external PCs are relieved and you can process data freely according to your requirements. This helps you to improve the efficiency of your processes and to secure your investments.

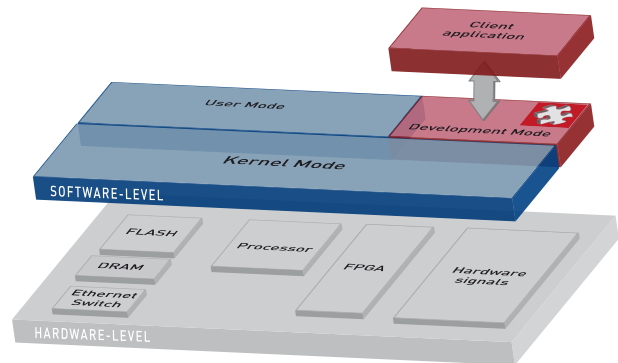

Anti-aliasing filter

Low-pass filters are used before or during digitising in order to remove all frequency components which are higher than the Nyquist frequency. This is to make sure that the digitised value or result does not contain any unwanted frequencies (aliasing frequencies). According to the Nyquist criterion, in order to obtain the full signal information, the sampling rate must be at least 2 x the signal band width.

Firmware and software adaptation

Because MSX-E systems are very flexible, the MSX-E3601 firmware can be easily extended. Thus, calculations such as RMS or limit values etc. can be integrated. Using the Development Mode, it is possible to create self-sufficient intelligent nodes.

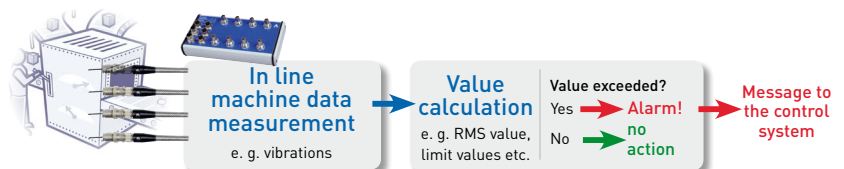

ConfigTools

The **ConfigTools** program allows an easy administration of the MSX-E systems. These are automatically detected in the network. **ConfigTools** consists of common and specific functions. In addition, with **ConfigTools**, the complete configuration of a MSX-E system can be saved and transferred to another system of the same type (clone function).

ConfigTools is included in the delivery.

ConfigTools functions for MSX-E3601 / MSX-E3601-2:

- Change of IP address
- Display of web interface
- Firmware update
- Save/load system configuration
- Save/load channel configuration

Very easy use through the „ConfigTools“ program; The MSX-E system is automatically detected in the network.

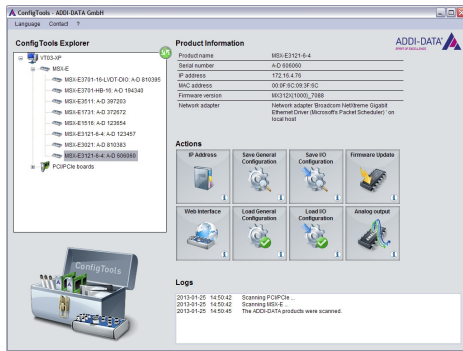

Features

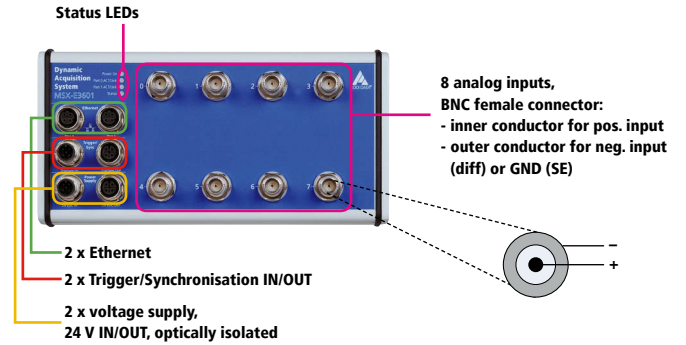

Simplified block diagram

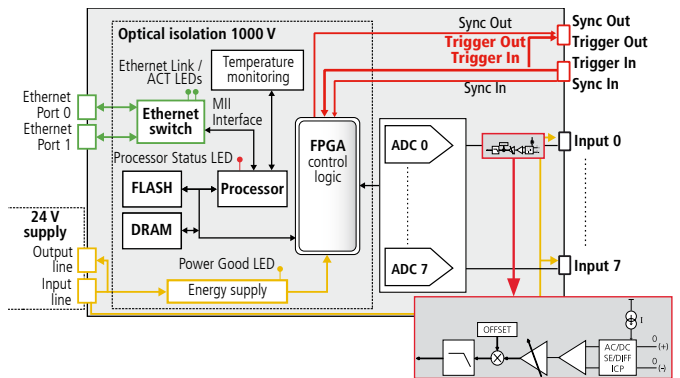

Cascading

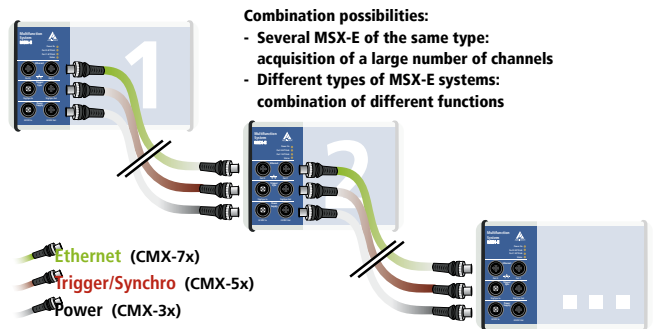

ADDI-DATA connection technology

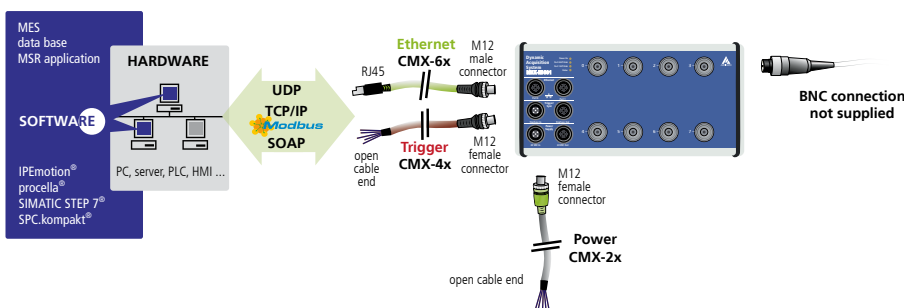

5V digital	24V digital	B _K E NPN 24 V dig. input	A B incremental
PWM	A Sin 1 V _{pp}	B Cos 11 μA _{pp}	ICP sensor
EnDat 2.2	SSI	I current	thermocouple element
U voltage	NTC temperature	Pt100	VLDT inductive transducer
DMS	HB inductive transducer	LVDT inductive transducer	TTY serial
RS232 serial	RS422 serial	RS485 serial	



Specifications

Analog inputs

Number of inputs:	MSX-E3601: 8, 1 AD converter per channel MSX-E3601-2: 2, simultaneous acquisition, 1 AD converter per channel
Coupling:	DC, AC (software-configurable)
Input type:	single-ended or differential (software-configurable)
Input ranges	SE Diff.
Gain x1:	± 10 V single-ended ± 5 V differential
Gain x10:	± 1 V single-ended ± 0.5 V differential
Gain x100:	± 0.1 V single-ended ± 0.05 V differential
ADC-Type:	Oversampled SAR with linear phase FIR antialiasing digital filter
Resolution:	24-bit
Sampling rate f_s :	up to 128 kHz
Selectable frequencies f_s :	128000.00 100000.00 80000.00 66666.67 64000.00 50000.00 40000.00 33333.33 32000.00 25000.00 20000.00 16666.67 16000.00 13333.33 12800.00 12500.00 10000.00 8000.00 6666.67 6400.00 6250.00 5000.00 4000.00 3333.33 3200.00 3125.00 2500.00 2000.00 1666.67 1600.00 1562.50 1280.00 1000.00
Oversampling:	8 x f_s
Frequency accuracy:	± 50 ppm
Input stage characteristics	
Input impedance:	1 M Ω // 300 pF typ., DC coupled
AC cutoff frequency (-3 dB):	0.48 Hz typ.
Overvoltage protection:	Positive input +27 V/-14 V, ± 100 mA Max. continuous current Negative input ± 14 V, ± 100 mA Max. continuous current
Filter response	
Passband:	DC up to 0.453 x f_s typ.
Passband ripple:	+/-0.01 dB max. DC up to 0.453 x f_s
Bandwidth (-3 dB):	0.49 x f_s typ.
Stop band:	0.547 x f_s typ.
Stop band attenuation:	100 dB min.
Group delay:	37/ f_s (μ s) typ.
Settling time (latency):	74/ f_s (μ s) complete settling
Dynamic characteristics	
Signal-to-noise ration (SNR):	FSR, f_{in} = 1 kHz ≥ 95 dB Gain x1 ≥ 94 dB Gain x10 ≥ 75 dB Gain x100
Total Harmonic Distortion (THD):	FSR, f_{in} = 1 kHz ≥ 100 dB Gain x1 ≥ 100 dB Gain x10 ≥ 90 dB Gain x100
Dynamic range:	Shorted inputs ≥ 105 dB Gain x1 ≥ 100 dB Gain x10 ≥ 85 dB Gain x100

Crosstalk:	Between channels 0-1, 2-3, 4-5, 6-7, with gain x1 ≥ 104 dB short input, f_{in} = 100 Hz ≥ 100 dB short input, f_{in} = 1 kHz ≥ 104 dB 50 Ω input, f_{in} = 100 Hz ≥ 100 dB 50 Ω input, f_{in} = 1 kHz
Phase mismatch:	Between channels 1-2, 3-4, 5-6, 7-8, with gain x1 ± 0.001° f_{in} < 100 Hz ± 0.01° f_{in} < 1 kHz ± 0.1° f_{in} < 10 kHz
Amplitude accuracy:	± 0.009 dB max. at f_{in} = 1 kHz sine signal, Gain x1, x10, x100
CMRR:	> 110 dB typ. at DC > 90 dB typ. at f_{in} < 1000 Hz
Offset error:	± 90 μ V after calibration at 25 °C
Onboard DC calibration:	Software-configurable
Calibration voltage:	5 V typ. Gain x1 900 mV typ. Gain x10 90 mV typ. Gain x100
Temperature drift:	± 8 ppm/°C typ.
Sensor supply voltage	
Number of channels:	8 (MSXE-3601) or 2 (MSX-E3601-2) positive input
Current source:	4 mA typ. to 24 V max.
Coupling:	AC (positive input) GND (negative input)
Recording duration:	TBD max. at 128 kHz sampling rate on 8 channels

Current sources

Number:	8 or 2 constant current sources for the supply of the ICP® or IEPE sensors, 4 mA typ., 24 V max.
---------	--

Voltage supply, Ethernet, Trigger, Synchro

The specifications for the voltage supply, Ethernet, Trigger, Synchronisation and Electromagnetic Compatibility apply to all MSX-E systems. See page 31.

EMC – Electromagnetic compatibility

The product complies with the European EMC directive. The tests were carried out by a certified EMC laboratory in accordance with the norm from the EN 61326 series (IEC 61326). The limit values as set out by the European EMC directive for an industrial environment are complied with. The respective EMC test report is available on request.

System features

Interface:	Ethernet acc. to specification IEEE802.3
Dimensions:	215 x 110 x 52 mm
Weight:	860 g
Degree of protection:	IP 65
Current consumption at 24 V:	350 mA typ.
Operating temperature:	-40 °C to +85 °C
Connectors for sensors	
for analog inputs:	8 x BNC female connector (MSX-E3601) 2 x BNC female connector (MSX-E3601-2)

Ordering information

MSX-E3601 / MSX-E3601-2

Ethernet system for the acquisition of dynamic signals, 8 or 2 SE/diff. inputs, 24-bit, simultaneous acquisition. Incl. technical description, software drivers and ConfigTools.

Versions

MSX-E3601:	8 SE/diff. inputs
MSX-E3601-2:	2 SE/diff. inputs

Connection cables

Voltage supply

CMX-2x:	Shielded cable, M12 5-pin female connector/open end, IP 65
CMX-3x:	For cascading, shielded cable, M12 5-pin female connector/male connector IP 65

Trigger/Synchro

CMX-4x:	Shielded cable, M12 5-pin female connector/open end, IP 65
CMX-5x:	For cascading, shielded cable, M12 5-pin female connector/male connector IP 65

Ethernet

CMX-6x:	CAT5E cable, M12 D-coded male connector/RJ45 connector
CMX-7x:	For cascading, CAT5E cable, 2 x M12 D-coded male connector

Options

S7 Modbus TCP Client Library for S7:	Easy use of the Ethernet systems MSX-E with PLCs
MSX-E 5V-Trigger:	Level change of the trigger inputs and outputs to 5 V
MX-Clip, MX-Rail	(please specify when ordering!),
MX-Screw, PCMX-1x	