



- Construction en Acier Inoxydable
- Haute précision
- Degré de protection IP60
- Mesure de traction et compression
- Grande stabilité à long terme
- *Stainless steel construction*
- *High accuracy*
- *Level protection IP60*
- *Tension and compression force*
- *High longlife testing machines*

Câblage - Wiring

+ alim.	+ signal	- signal	- alim.	Cran de calibration*	Masse
+ excit.	+ signal	- signal	- excit.	Calibration control*	Shield
borne 2	borne 4	borne 5	borne 1	borne 6	borne 3
pin 2	pin 4	pin 5	pin 1	pin 6	pin 3

\* option

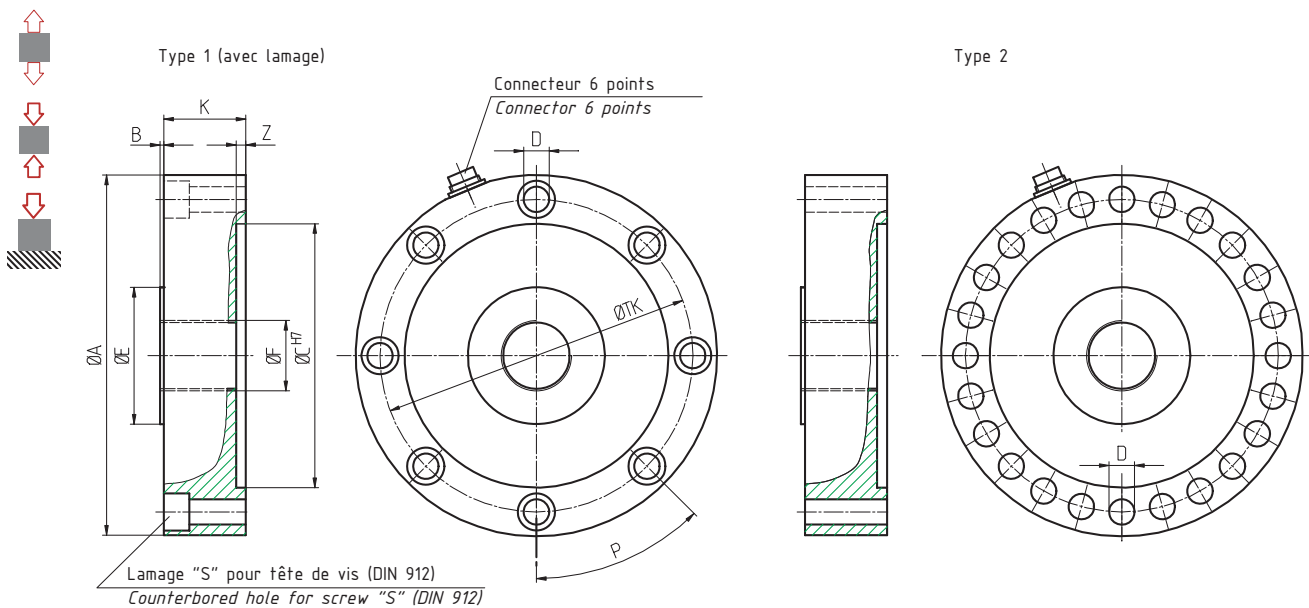

Toutes dimensions en mm. Dimensions et spécifications non contractuelles.  
Dessins techniques disponibles sur demande.  
All dimensions in mm. Dimensions and specifications do not constitute any liability whatsoever.  
Technical drawings are available on request.

Charge Nominale (Cn) Nominal Force [kN]	Dimensions - Dimension [mm]											Couple de serrage Tightening torque [Nm]	
	Ø A	B	Ø C	Ø D	Ø E	Ø F	K	Ø TK	P	Z	S		Type
0.5, 1, 2, 5, 10	90	2	60	6.6	25	M12x1.75	32	75	4 x 90°	2	M6	1	M6-14
20, 50	150	2	105	11	55	M24x2	38	130	8 x 45°	2	M10	1	M10-70
100, 200	185	2	135	13	70	M36x3	42	160	8 x 45°	3	M12	1	M12-125
500	240	2	160	17	90	M45 x 3	60	200	12 x 30°	3	M16	1	M16-300
1 000	295	5	200	21	130	M80 x 4	95	250	12 x 30°	4	M20	2	M20-590
2 000	390	3	270	26	190	M120 x 4	117	330	24 x 15°	4	M24	2	M24-1020

# K11

0 ... 0.5 kN à 0 ... 2 000 kN

## Caractéristiques - Specifications

MÉCANIQUES	MECHANICAL		
Charge Nominale (Cn)	Nominal Force (Cn)	Voir page 1 - See page 1	kN
Force de travail admissible	Service load	130	% Cn
Force max. sans détérioration	Limit load		% Cn
Force ultime avant rupture	Ultimate load	> 300	% Cn
Déflexion sous force nominale	Position feedback at nominal load	≤ 0.12	mm
PRÉCISIONS	ACCURACY		
Répétabilité	Repeatability	≤ ±0.3	% Cn
Hystérésis	Hysteresis	≤ ±0.3	% Cn
Erreur de linéarité en traction <b>OU</b> compression	Linearity error for tension <b>OR</b> compression	≤ ±0.05*	% Cn
Erreur de linéarité en traction <b>ET</b> compression	Combined error for tension <b>AND</b> compression	≤ ±0.15*	% Cn
ÉLECTRIQUES	ELECTRICAL		
Tension d'alimentation	Supply voltage	2 ... 12	Vcc
Tension d'alimentation max.	Max. supply voltage	15	Vcc
Signal de sortie	Output signal	2.00	mV/V ±0.2 %
Impédance du pont	Bridge resistance	350	Ω
Résistance d'isolement	Insulation resistance	> 2 x 10 <sup>9</sup>	Ω
GÉNÉRALES	GENERAL		
Plage de température compensée	Nominal temperature range	-10 ... +70	°C
Plage de température opérationnelle	Service temperature range	-30 ... +80	°C
Dérive thermique du signal	Temperature coefficient of sensitivity	< ±0.005	% Cn/°C
Dérive thermique de zéro	Temperature coefficient of zero signal	< ±0.003	% Cn/°C
Degré de protection (DIN EN 60529)	Level of protection (DIN EN 60529)	IP60	
Matériau	Material	Acier inoxydable - Stainless steel	
Connexion	Connection	Connecteur - Connector	6 points

\* Attention : Cn = 1 000 kN : 0.2 % Cn ; Cn = 2 000 kN : 0.4 % Cn

## Options - Options

Cran de calibration	Calibration control	100 % Cn
Plage de température compensée	Nominal temperature range compensated	-30 ... + 100 (Cn ≥ 2kN : -40 ... +150)

## Accessoires - Accessories

Cn [kN]	ØD	A	B	C	SW	R	T
0.5 ... 10	22	12	24	M12x1.75	18	60	1
20, 50	52	15	30	M24x2	45	230	1.5
100, 200	65	15	30	M36x3	45	295	1.8
500	85	20	40	M45x3	50	450	2.0
1 000	125	50	90	M80x4	95	780	2.5
2 000	190	70	120	M120x4	170	1000	4.5

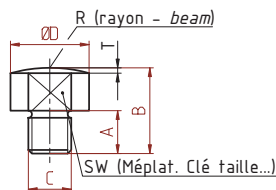

Bouton de charge E2 Load adapter



CPJ



PAX