



8B34

Linearized 2- or 3-Wire RTD Input Modules

Description

8B modules are an optimal solution for monitoring real-world process signals and providing high-level signals to a data acquisition system. Each 8B34 input module isolates, filters, amplifies, and linearizes a single channel of temperature input from an RTD and provides an analog voltage output (Figure 1).

RTD excitation is provided from the module using two matched current sources. When using a 3-wire connection, this method allows equal currents to flow through the sensor leads, canceling the effects of lead resistances. The excitation currents are small (0.25mA) which minimizes self-heating of the RTD.

Signal filtering is accomplished with a 3-pole filter optimized for time and frequency response which provides 70dB of normal-mode rejection at 60Hz. One pole of this filter is on the field side of the isolation barrier for anti-aliasing, and the other two are on the system side.

A special input circuit on the the 8B34 module provides protection against accidental connection of power-line voltages up to 240VAC. Clamp circuits on the I/O and power terminals protect against harmful transients.

The modules are designed for installation in Class I, Division 2 hazardous locations and have a high level of immunity to environmental noise.

► Features

- Interfaces to 100Ω Platinum RTDs
- Linearizes RTD Signal
- High-Level Voltage Outputs
- 1500Vrms Isolation
- ANSI/IEEE C37.90.1 Transient Protection
- Input Protection to 240VAC Continuous
- 120dB CMR
- 70dB NMR at 60Hz
- Low Drift with Ambient Temperature
- C-UL-US Listed
- CE Compliant
- ATEX Compliance Pending
- Mix and Match Module Types on Backpanel

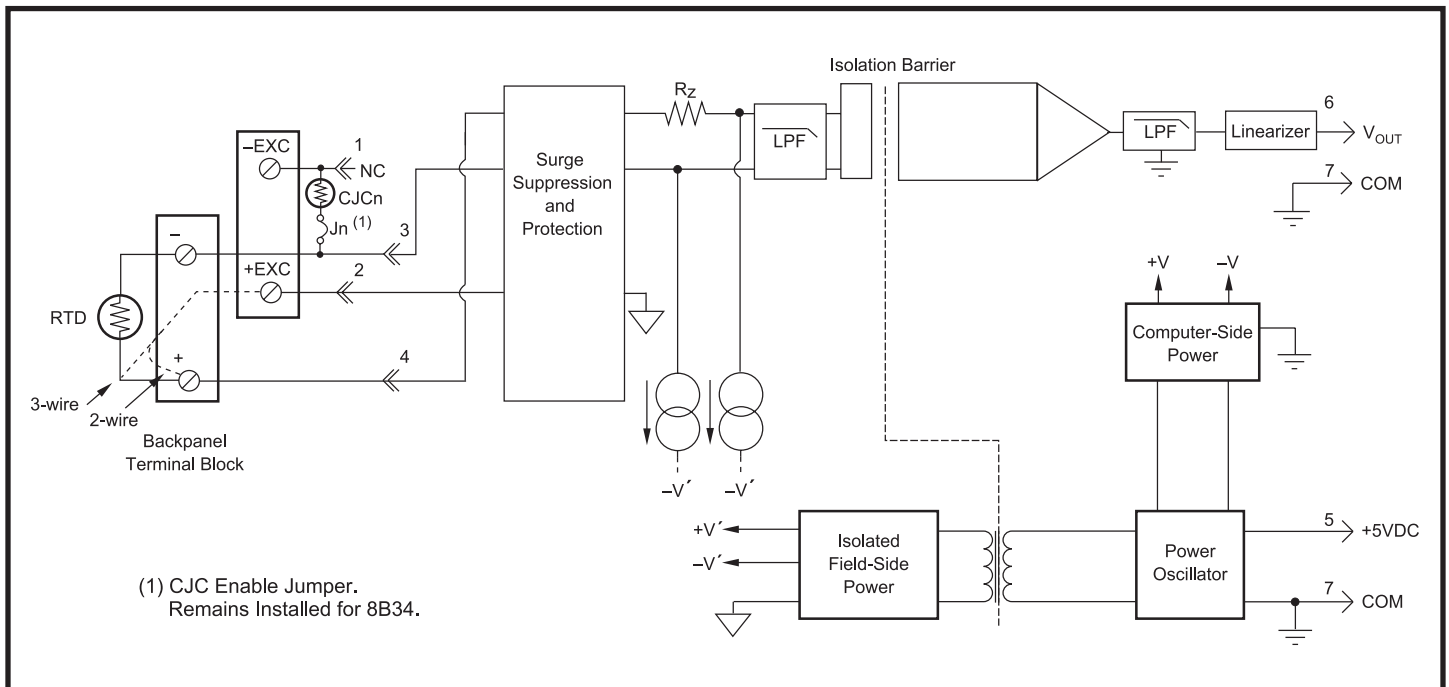

Figure 1: 8B34 Block Diagram

Specifications Typical* at T_A=+25°C and +5VDC power

Module	8B34
Input Range Limits	-200°C to +850°C (100Ω Pt)
Input Resistance	
Normal	50MΩ
Power Off	200kΩ
Overload	200kΩ
Input Protection	
Continuous ⁽¹⁾	240VAC
Transient	ANSI/IEEE C37.90.1
Sensor Excitation Current	0.25mA
Lead Resistance Effect	±0.02°C/Ω ⁽²⁾
CMV, Input to Output	1500Vrms max
Transient, Input to Output	ANSI/IEEE C37.90.1
CMR (50 or 60Hz)	120dB
NMR	70dB at 60Hz
Accuracy	See Ordering Information
Stability	
Offset	±20ppm/°C
Gain	±50ppm/°C
Noise	
Output, 100kHz	200μVrms
Bandwidth, -3dB	3Hz
Response Time, 90% Span	150ms
Output Range	See Ordering Information
Output Protection	Continuous Short to Ground
Transient	ANSI/IEEE C37.90.1
Open Input Response	Downscale
Open Input Detection Time	1s
Power Supply Voltage	+5VDC ±5%
Power Supply Current	25mA
Power Supply Sensitivity	±75ppm/%
Mechanical Dimensions (h)(w)(d)	1.11" x 1.65" x 0.40" (28.1mm x 41.9mm x 10.2mm)
Environmental	
Operating Temperature Range	-40°C to +85°C
Storage Temperature Range	-40°C to +85°C
Relative Humidity	0 to 95% Noncondensing
Emissions EN61000-6-4	ISM, Group 1
Radiated, Conducted	Class A
Immunity EN61000-6-2	ISM, Group 1
RF	Performance A ±0.5% Span Error
ESD, EFT	Performance B

NOTES:

- * Contact factory or your local Dataforth sales office for maximum values.
 (1) 240VAC between +Input terminal and -Input, +EXC, or -EXC terminals.
 120VAC between -Input and +EXC or -EXC terminals.
 120VAC between +EXC and -EXC terminals.
 (2) "Ω" refers to the resistance in one lead.
 (3) Includes conformity, hysteresis and repeatability.

Ordering Information

Model	Input Range	Output Range	Accuracy ⁽³⁾
100Ω Pt **			
8B34-01	-100°C to +100°C (-148°F to +212°F)	0V to +5V	±0.20°C
8B34-02	0°C to +100°C (+32°F to +212°F)	0V to +5V	±0.10°C
8B34-03	0°C to +200°C (+32°F to +392°F)	0V to +5V	±0.20°C
8B34-04	0°C to +600°C (+32°F to +1112°F)	0V to +5V	±0.45°C

****RTD Standards**

Type	Alpha Coefficient	DIN	JIS	IEC
100Ω Pt	0.00385	DIN 43760	JIS C 1604-1989	IEC 751