

# Digital I/O board, 32 isolated channels, 24 V

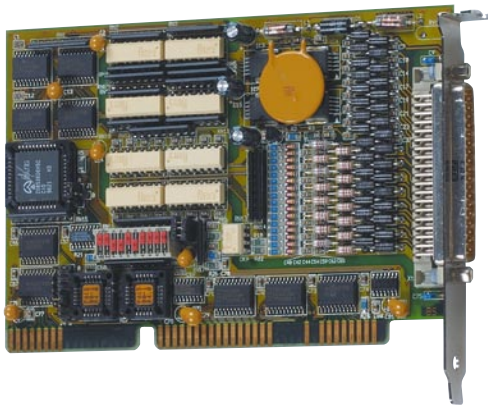

LabVIEW™



LabWindows/CVI™

## Features

### Inputs

- 16 isolated inputs, 24 V, incl. 14 interruptible
- Voltage reversal protection
- All inputs are filtered

### Outputs

- 16 isolated outputs, 10 to 36 V
- Output current per channel 500 mA
- At Power-on, the outputs are reset to "0"
- Timer-programmable watchdog for resetting the outputs to "0"
- Diagnostic report through status register in case of short-circuit, overtemperature, voltage drop or watchdog
- Short-circuit current for 16 outputs ~ 3 A typ.
- Short-circuit current per output ~1.5 A typ.
- Self resetting fuse (electronic fuse)
- Overtemperature and overvoltage protection
- 24 V power output with protective diodes and filters
- Output capacitors minimise electromagnetic emissions
- Voltage supply screened through a protective circuitry
- Interrupt triggered through watchdog
- Address range freely configurable through DIP switches, 8-bit/16-bit access

### Safety features

- Optical isolation 1000 V
- Creeping distance IEC 61010-1 (VDE411-1)
- Protection against fast transients (Burst), overvoltage, electrostatic discharge and EMI
- Separate ground line for the inputs and the outputs
- Shut-down logic when the external supply voltage drops below 5 V.

### Protective circuitry for the input channels

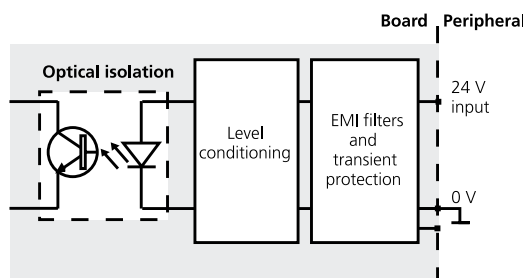

## PA 1500

16 digital inputs 24 V,  
incl. 14 interruptible inputs

16 digital outputs, 24 V, 500 mA/channel

Optical isolation 1000 V

Input and output filter

Watchdog

At power-on the outputs are reset to "0"

Timer

### EMC tested acc. to 89/336/EEC

- IEC 61326: electrical equipment for measurement, control and laboratory use

### Applications

- PLC connection
- Control of industrial PC-based process
- Industrial measurement
- Acquisition of sensor data
- Signal analysis
- Machine interface
- ...

### Software drivers

A CD-ROM with the following software and programming examples is supplied with the board.

#### Standard drivers for:

- Windows XP/2000/NT/98/95, Windows 3.11, MS-DOS,
- Real-time drivers for Windows XP/2000/NT/98/95
- Monitorprogramm ADDIMON

#### Drivers for the following application software:

- LabVIEW 5.01, LabWindows/CVI 5.01

#### Samples for the following compilers:

- Microsoft VC++ 5.0, Microsoft C 6.0, Borland C++ 5.01,
- Borland C 3.1, Visual Basic 5.0, Delphi 4,
- Turbo Pascal 7.0

#### On request:

- DiaDem 6, Visual Basic 1.0

Current driver list on the web: [www.addi-data.com](http://www.addi-data.com)

### Protective circuitry for the output channels

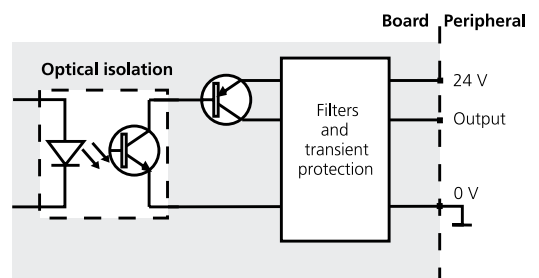

# Digital I/O board, 32 isolated channels, 24 V

PA 1500

## Specifications

### Digital inputs

Number of inputs:	16 (Common ground acc. to IEC 1131-2)
Optical isolation:	through optical couplers, 1000 V from the PC to the peripheral
Interruptible inputs:	14 of the 16 digital inputs
Interrupt lines:	IRQ 3, 5 for XT, IRQ 10, 11, 12, 14, 15 for AT
Interrupt comparison logic:	AND and OR mode; OR priority
Nominal voltage:	24 V
Input current at 24 V:	6 mA typ.
Logic input level:	U nominal: 24 V UH max.: 30 V/current 9 mA typ. UH min.: 19 V/current 2 mA typ. UL max.: 14 V/current 0,6 mA typ. UL min.: 0 V/current 0 mA typ.
Signal delay:	70 µs (at 24 V)
Maximum input frequency:	5 kHz (at 24 V)

### Digital outputs

Outputs:	16 outputs, isolated up to 1000 V
Output type:	High-side (Load at ground) acc. to IEC 1131-2
Nominal voltage:	24 V
Supply voltage:	10 to 36 V, min. 5 V (through front connector)
Max. current for 16 outputs:	3 A typ.
Output current/output:	500 mA typ.
Output current for 16 channels:	200 mA typ. per channel
Short-circuit current/output	
Shut-down at 24 V, Rload < 0.1Ω:	1.5 A
RDS ON resistance:	0.4 Ω max.
Switch-on time:	I <sub>out</sub> =0.5 A, Load = resistance: 120 µs
Switch-off time:	I <sub>out</sub> =0.5 A, Load = resistance: 40 µs
Overtemperature (shut-down):	170 °C (output driver)
Temperature hysteresis:	20 °C (output driver)

### Safety

Shut-down logic:	When the ext. 24 V voltage drops below 5 V: the outputs are switched off. Diagnostic: status bit or interrupt to PC
Watchdog:	Timer-programmable, 5 µs to 9 s

### EMC – Electromagnetic compatibility

The product complies with the European EMC directive. The tests were carried out by a certified EMC laboratory in accordance with the norm from the EN 61326 series (IEC 61326). The limit values as set out by the European EMC directive for an industrial environment are complied with. The respective EMC test report is available on request.

### Physical and environmental conditions

Dimensions:	156 x 99 mm
System bus:	ISA
Place required:	Short board, 1 AT or XT slot
Operating voltage:	+5 V, ± 5 % from PC
Current consumption:	229 mA ±10 mA typ.
Front connector:	37-pin SUB-D male connector
Temperature range:	0 to 60 °C (with forced cooling)

## Simplified block diagram

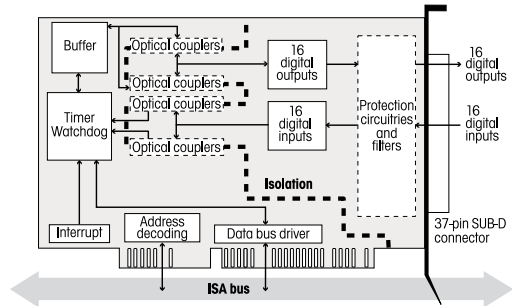

## Pin assignment – 37-pin SUB-D male connector

Reserve	19	37	Dig. output 16
Dig. output 15	18	36	Dig. output 14
Dig. output 13	17	35	Dig. output 12
Dig. output 11	16	34	Dig. output 10
Dig. output 9	15	33	Dig. output 8
Dig. output 7	14	32	Dig. output 6
Dig. output 5	13	31	Dig. output 4
Dig. output 3	12	30	Dig. output 2
Dig. output 1	11	29	0 V ext. (Outputs)
(Inputs) 0 V ext.	10	28	24 V ext.
24 V ext.	9	27	Dig. input 16
Dig. input 15	8	26	Dig. input 14
Dig. input 13	7	25	Dig. input 12
Dig. input 11	6	24	Dig. input 10
Dig. input 9	5	23	Dig. input 8
Dig. input 7	4	22	Dig. input 6
Dig. input 5	3	21	Dig. input 4
Dig. input 3	2	20	Dig. input 2
Dig. input 1	1		

## ADDI-DATA connection

### Example 1

Connection of the inputs and outputs through screw terminals boards

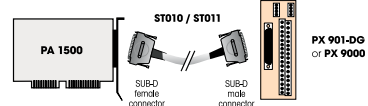

### Example 2

- Connection of the inputs through screw terminal board PX 901-DG  
- Connection of the outputs through relay output board PX 8500-G in cascade for 16 relays

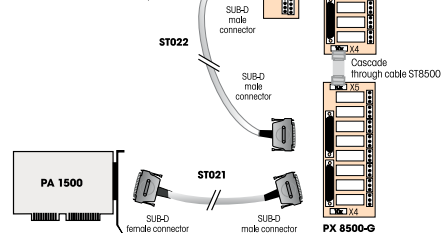

## Ordering information

### PA 1500

Digital I/O board, 32 isolated channels, 24 V. Incl. technical description and software drivers.

### Connection

<b>PX 901-D:</b>	Screw terminal panel, LED status display
<b>PX 901-DG:</b>	Screw terminal panel for DIN rail, LED status display
<b>PX 9000:</b>	3-row screw terminal panel for DIN rail, LED status display
<b>PX 8500-G:</b>	Relay output board for DIN rail, cascadable
<b>ST010:</b>	Standard round cable, shielded, twisted pairs, 2 m
<b>ST011:</b>	Standard round cable, shielded, twisted pairs, 5 m
<b>ST010-S:</b>	Same as ST010, for high currents (24V supply separated)

<b>ST021:</b>	Round cable between PA 1500 and PX 8500, shielded, twisted pairs, 2 m
<b>ST022:</b>	Round cable between PX 8500 and PX 901, shielded, 2 m
<b>ST8500:</b>	Ribbon cable for cascading two PX 8500