

DC/DC Displacement Sensors

Model 8740

Model 8741 with spring probe tip

Code:	8740 EN
Delivery:	ex stock
Warranty:	24 months

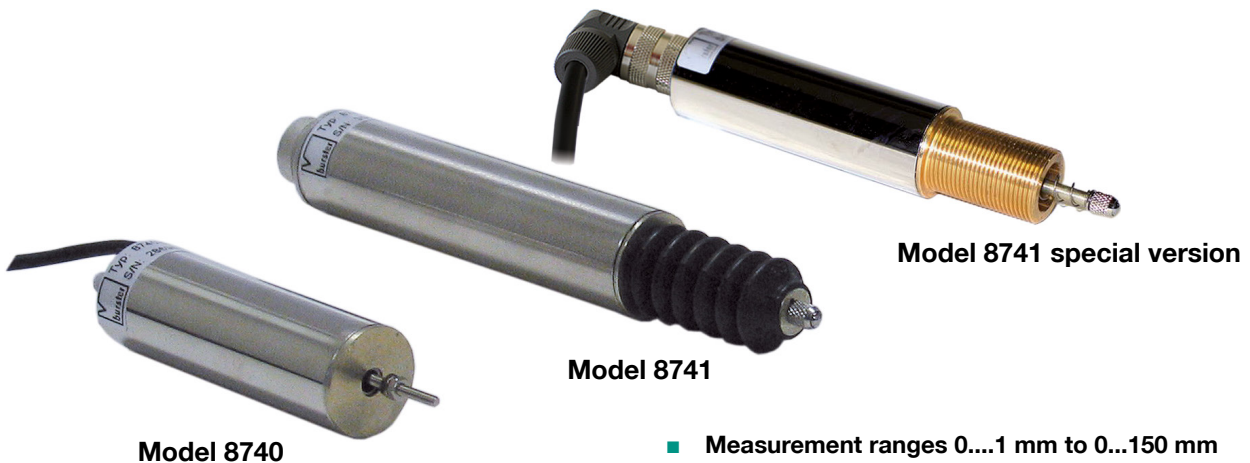

Model 8740

Model 8741

Model 8741 special version

- Measurement ranges 0...1 mm to 0...150 mm
- Non-linearity ± 0.25 % F.S., optional to 0.1 % F.S.
- Integrated measuring amplifier, output 0 ... 5 V
- Optional 0 ... 10 V, 4 ... 20 mA
- Potted electronics not susceptible to vibration or impact
- Special versions on request (see options)

Application

Inductive displacement sensors using the principle of the differential transformer (LVDT) can be used to measure displacement and, indirectly, magnitudes that can be converted into displacements such as force, pressure, strain, torque, vibration and so forth.

Thanks to the high quality of their measurements, their high protection and long service life, these sensors are used in many technologies (industry, research, development, etc.).

Applications include measuring, controlling, regulating and monitoring both slow and fast movements between machine parts, measurements of position and positional changes of components and structural foundations, servo regulators, valve and robot controllers, growth measurements and so on.

Their design is robust - the internal coils and electronics are potted - as a result of which the sensors can easily withstand shock and vibration. This makes the sensors also suitable for mobile applications (e.g. in vehicles) and for test installations where they will be subject to many test cycles.

Description

These inductive displacement sensors with integrated electronics incorporate a differential transformer and a carrier frequency measuring amplifier, potted and protected by a stainless steel housing.

The differential transformer consists of one primary winding and two secondary windings; these are arranged symmetrically on either side of the primary winding. The integrated electronics demodulates, filters and amplifies the AC voltage induced in the secondary windings. A rod-shaped core is able to move inside the differential transformer.

As an output, the sensor delivers a DC voltage whose magnitude proportionally depends on the position of the moveable core inside the sensor.

Model 8740 incorporates a freely moveable, non-sprung core with two sliding Teflon rings that center the core in the hole through the body of the sensor. At the end of the moving rod is an M2 thread that can be used to couple the core mechanically to the object being measured. Any lateral force acting on the rod should be avoided.

The moveable rod of **model 8741** is mounted on ball bearings. A spring holds the tip of the probe against the object being measured. This version is advantageous when it is difficult or entirely impractical to implement a mechanical coupling. Once again, lateral forces will shorten the service life. The measuring side of the sensor is protected against pollution and splash water by a bellows.

Technical Data

Model 8740

Order Code	Measuring Range	Dimensions [mm]					Cut-Off Frequency [Hz]	Sensor Weight [g]	Moveable Mass [g]
		L	øD	øC	K	S			
8740 - 5001	0 ... 1 mm	45	20	4	27	34	300	30	2
8740 - 5002	0 ... 2 mm	45	20	4	27	34	300	30	2
8740 - 5005	0 ... 5 mm	61	20	4	45	40	150	60	3.3
8740 - 5010	0 ... 10 mm	61	20	4	45	40	150	60	3.3
8740 - 5025	0 ... 25 mm	91	20	4	56	69	100	90	4.7
8740 - 5050	0 ... 50 mm	151	20	4	97	84	100	130	6.9
8740 - 5100	0 ... 100 mm	271	20	4	136	164	100	250	11.7
8740 - 5150	0 ... 150 mm	441	20	4	288	212	100	400	17.1

Dimensional drawing

Model 8740

with optional fastening thread (V302 - see options on page 3)

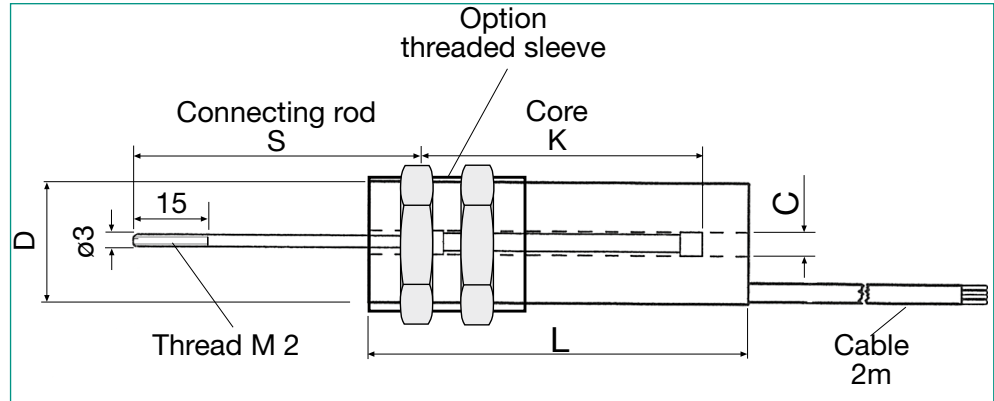

Model 8741

Order Code	Measuring Range	Dimensions [mm]						Tip Force max. [N]	Natural Frequency [Hz]	Masse des Senors [g]
		lg	LG	l	h	øD	ød			
8741 - 5001	0 ... 1 mm	98	66	25	3	20	4.5	2	10	85
8741 - 5002	0 ... 2 mm	98	66	25	4	20	4.5	2	10	85
8741 - 5005	0 ... 5 mm	125	84	34	7	20	4.5	3	10	110
8741 - 5010	0 ... 10 mm	130	84	39	12	20	4.5	3	5	120
8741 - 5025	0 ... 25 mm	190	133	50	27	20	4.5	5	5	150
8741 - 5050 *	0 ... 50 mm	310	210	90	70.5	20	4.5	8	5	250

* To protect the ball bearing guides, sensors with this measuring range have a sealing lip instead of the bellows.

Dimensional drawing model 8741

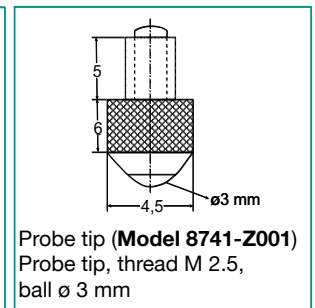
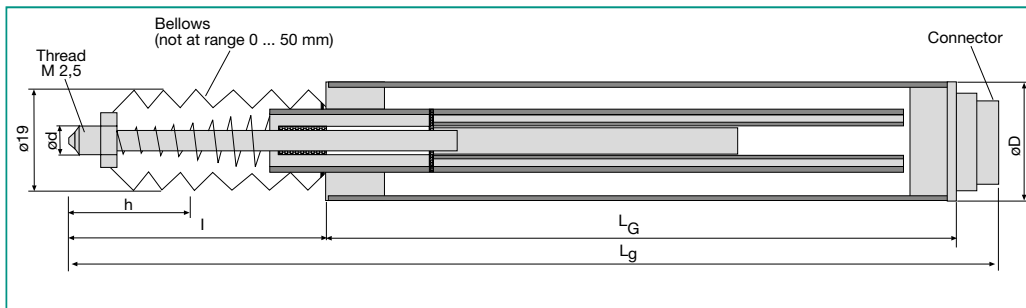

Dimensional drawing model 8741-5050

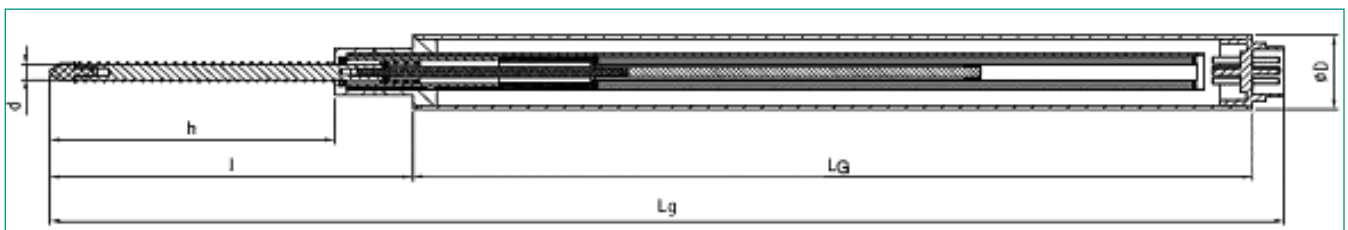

The CAD drawing (3D/2D) for this sensor can be imported online directly into your CAD system.

Download via www.burster.com or directly at www.traceparts.com. For further information about the burster traceparts cooperation refer to data sheet 80-CAD-EN.

Electrical values

Excitation voltage (protected against polarity reversal):	9 ... 28 V DC
Current consumption:	≤ 30 mA
Output voltage (standard):	0 ... 5V
Ripple of output voltage:	approx. 20 mVeff
Internal carrier frequency:	12 kHz
Output resistance:	1 kΩ
Load resistor:	recommended >1 MΩ

Environmental conditions

Range of operating temperature:	from -20 °C to 80 °C
Range of nominal temperature:	from -20 °C to 80 °C
Influence of temperature*:	0.03 % F.S./K

* with reference to the rated temperature range

Mechanical values

Linearity deviation:	< 0.25% F.S.
Variation in unchanged mounting position:	< 0.01% F.S.
Material:	ST 37, nickel-plated
Protection class:	according to EN 60529 model 8740 IP65 model 8741 IP40
General dimensional tolerances:	according to ISO 2768-f

Electrical connection

Model 8740 3 wire, screened PVC cable, ϕ 3 mm, bending radius \geq 20 mm, length 2 m

Model 8741 connector 7 pin, (model 9952 mating connector is included in scope of delivery)

Wiring: Model 8740 with 2 m connection cable Model 8741 for 7 pin connector

Excitation (+)	brown	1
Signal (+)	green	2
Excitation/signal (-)	white	3

(Connect screen to ground)

Mounting Instructions

Fastening the sensor body using a holder or the mounting thread (see Fig. 1 to Fig. 3).

Coupling to the moveable rod (8740) with thread M 2 x 1.5 (2 nuts are included in scope of delivery).

Fastening options for the 8740 an 8741.

Order Information

Inductive displacement sensor 8740, measuring range 10 mm
Model 8740-5010

Inductive displacement sensor 8740, measuring range 25 mm, with mounting thread option M 24 x 1.5

Model 8740-5025-V302

Inductive displacement sensor 8741, measuring range 10 mm, with linearity deviation option \pm 0.15 % F.S.

Model 8741-501-V511

Accessories

Holder for model 8740 and 8741 **Model 8740-Z002** (see Fig. 1)

Fixing bracket for model 8740 an 8741 **Model 8740-Z003** (see Fig. 2)

for **model 8740:**

Plug, 12 pin for burster desktop devices **Model 9941**
Plug mounting, to the sensor cable **Model 99004**
 Only for connection to SENSORMASTER model 9163 desktop version **Model 99002**

for **model 8741:**

Mating connector (coupling socket), 7 pin, ϕ 18 mm, length 70 mm (included in scope of delivery) **Model 9952**

Mating connector, 7 pin, angled 90° IP40 length 30 mm **Model 9900-V557**

Connecting cable, 4 wire, length 3 m one end free **Model 99552-000A-0090030**

Connecting cable, 4 wire, for connection to the burster desktop devices **Model 99141-552A-0090030**

Probe tip, thread M 2.5, ball ϕ 3 mm (included in 8741 scope of delivery) **Model 8741-Z001**

Devices and systems for measurement data acquisition or process monitoring **see section 9 of catalog.**

Fig. 1

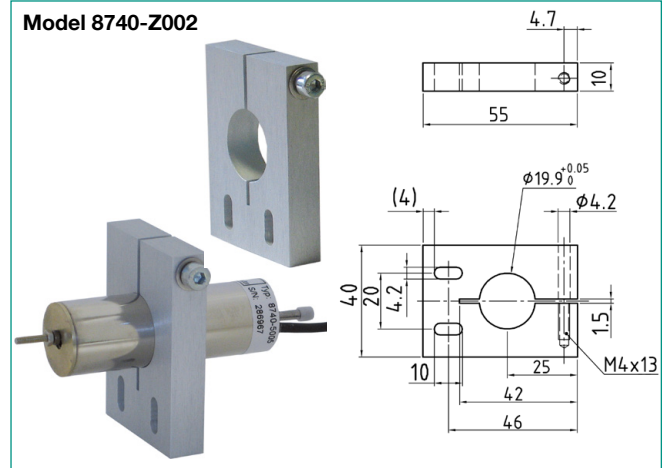

Fig. 2

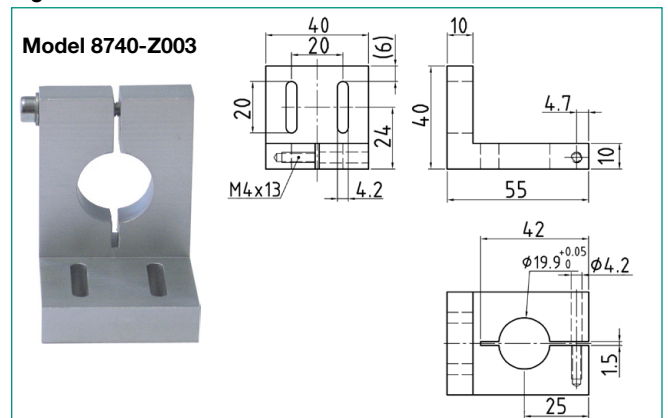
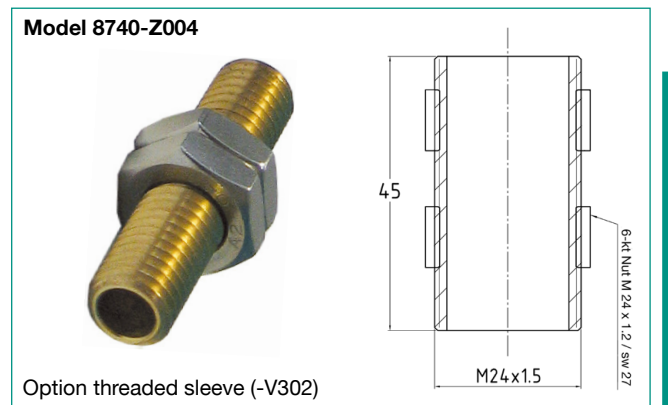

Fig. 3



Option threaded sleeve (-V302)

Options

V514: Inductive displacement sensor with current output 4-20 mA, excitation voltage 15-30 V

V201: Portable cable 3 m (other cable lengths on request)

V302: Sensor housing with mounting thread M 24 x 1.5 x 45 including 2 nuts (see drawing). The threaded sleeve is mounted flush at the front of the sensor housing.

V501: Output voltage 0 ... 10 V excitation voltage 13.5-28 V

V511: Linearity deviation \pm 0.15 % F.S.

Manufacturer Calibration Certificate (WKS)

Standard manufacturer calibration certificate in 20 % steps, rising, with or without indicator.

Special versions (by request)



Sensor with **radial cable outlet** **Option V606**

The radial cable outlet allows to use the space behind the sensor for other purposes.



Sensor with **mounting thread** **Option V302**

The unit can be fastened easily and without strain using the mounting thread and the 2 supplied nuts.

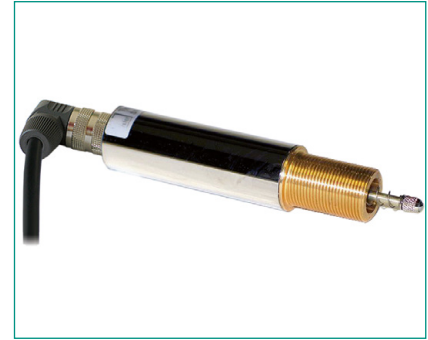

90° angled connector **Model 9900-V557**

Various alignment options and the housing thread permit easy adjustment of the sensor during mounting.

Application example

Task:

In a water bath a structured, metallic mesh is squeezed to a small diameter. The metallic mesh expands again as the water is heated. This expansion is to be measured by a very precise inductive displacement sensor, whose rod can move very smoothly within the body of the sensor. The expansion of the sample results in a movement of 15 mm. In spite of the extremely low weight of the sensor bat, it is necessary to ensure that its weight does not affect the measurement.

Solution:

Model 8740, with a measuring range of 25 mm, offers the necessary precision. It can measure the expansion accurately with its extremely light moveable rod in conjunction with a well-adjusted counterbalance. The optionally modifiable mounting thread allows it to be easily mounted without straining the sensor body. Extending the sensor's rod by means of a special ceramic tappet ensures that mechanical expansion as a result of temperature changes is almost entirely eliminated.

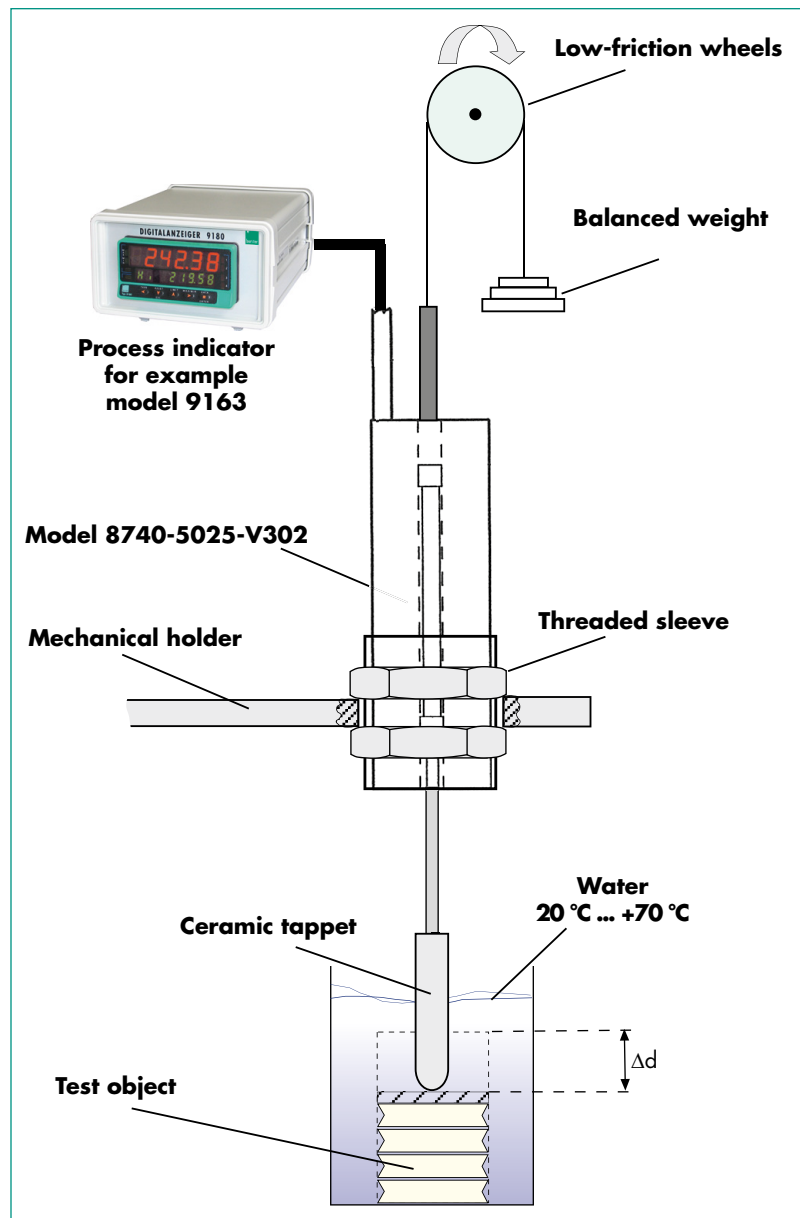

Fig. 4 Application example