

Description

The Princo Model L3515 and L3545 Presence/Absence Detectors are adjustable, RF impedance-sensing devices which, when connected to any Princo L600 Series Sensor Flange, can be used to detect the presence or absence of process material within a pipeline. The L3515 and L3545 units, with Sensor Flanges, are used for obstructionless presence/absence detection of liquids and solids in all types of process systems, and for run dry protection of positive displacement pumps.



Model L3515 with Sensor Flange

The units are provided with a continuously adjustable 0 to 30 second time delay to avoid unnecessary shutdowns due to momentary voids which might appear in the process stream. Also included as a standard feature is a push button, which permits easy pump startup with an empty line or which can be used to override normal control in an emergency.

Sensor flanges are available in standard pipe sizes ranging from 1 to 12 inches. The PRINCO L3545 is similar in operation to the L3515, except that the L3545 has a remote mounted sensor flange, which may be located up to 3000 feet away from the electronics unit. They are connected by means of an ordinary multiconductor (not coaxial) cable. A remote override (startup) feature is also provided. Reliable protection is thus available for applications where equipment must be located in inaccessible areas.

Applications

- Water-based liquids, slurries & sludge
- Acids
- Hydrocarbons and solvents
- Powders and granulars
- Oils

Performance

- **Wide Temperature Ranges** – Ambient temp: -40 to 150°F (-40 to 66°C); process temp: -300 to 500°F (-184 to 260°C).
- **Excellent Temperature Stability** – Less than 0.1 pF thermal drift per 20°F (less than 1.0 pF/200°F of ambient temperature change).
- **Non-Intrusive Sensor** – No flow interference.
- **High Sensitivity** – Extremely sensitive yet has a very high turn-down capability: 0.15 pF to 1000 pF.
- **No Moving Parts** – Nothing mechanical to wear out.
- **Designed to Survive** – RF immune and vibration-proof. Circuit boards conformally coated (tropicalized) for extra protection.

Features

- **Universal** – Wide selection of sensors provides for virtually every application and installation requirement.
- **NULL-KOTE™ Circuitry** – Makes the sensor immune to adverse effects caused by product build up.
- **Heavy Duty Relay** – Dual 5A, 115 Vac (resistive) control contacts.
- **Large Variety of Sensor Flange Sizes** – From 1 to 12 inches, completely interchangeable on all detectors.
- **Standard Sensors** – wetted surfaces of epoxy and 316SS (Teflon™/316SS also available).
- **Local or Remote Control Units** – In weatherproof/explosion-proof or weatherproof enclosures.
- **Pump Start Push Button** – Provides override for system startup.
- **Quick-Couple Tri-Clamp Connections** – Available for food, beverage, pharmaceutical, and cosmetic applications.
- **Adjustable Time Delay** – Prevents unnecessary shutdowns caused by air pockets.
- **Ten-Year Warranty** – The only level instruments available with this unique assurance of quality.

Models L3515 & L3545

Application

Progressive cavity pumps and other positive displacement pumps must be protected against "running dry". Pipelines and process systems often require a reliable indication of the presence or absence of material at specific points in the system. Overflow or waste lines should be monitored. Cooling and lubricating functions need safeguarding.

PRINCO's presence/absence detector can fulfill all such requirements. These unique instruments are designed to be installed in practically any pipe where an unrestricted flow is desired. Mounting it in a vertical pipe segment is preferred since it is desirable to have residual material drain away from sensor. However, operation of the sensor is possible in any position.



Sensor Flanges

Sensor flanges are available for the two distinct types of applications encountered in industry.

For non-conductive materials such as solvents, hydrocarbons, or dry products, the L631, L641, L651, or L661 sensor flange is recommended. They contain a full-ring sensor, which provides optimum output to the controller.

Conductive materials such as acids, brines, or sewage require the L632, L642, L652, or L662 sensor flange. They utilize a partial-ring sensor, which is ideal for these types of applications.

The L651, L652, L661, and L662 sensor flanges have been accepted by the USDA for use in federally inspected meat and poultry plants.

Standard sensors are manufactured from 150 lb. ASTM size carbon steel flanges and have wetted surfaces of epoxide resin and 316SS. Sensor flanges with wetted surfaces of Teflon and 316SS are also available.

Connection is typically made with flat-faced flanges and full-faced gaskets. Tri-Clamp fittings are also available.

Refer to the last page of this bulletin for complete specifications on sensor flanges.

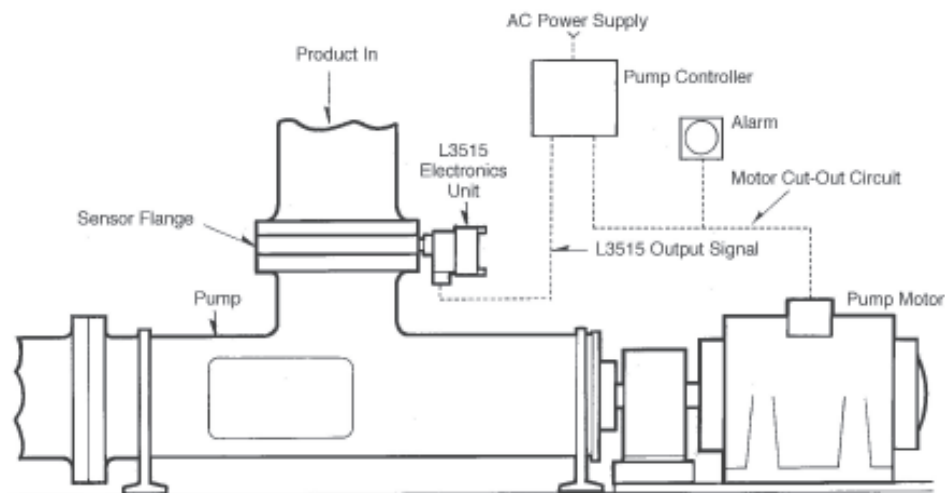

Typical installation on positive displacement pump.

Models L3515 & L3545

L3515 & L3545 Specifications

TYPE	Point type (on/off), solid state electronic, RF impedance-sensing, presence / absence detector.
POWER REQUIREMENTS	95 to 135 Vac, 50 to 60Hz or 205 to 250 Vac, 1.3 watts; or 12/34 Vdc, <1 Watt.
AMBIENT TEMPERATURE	-40 to 150 °F (-40 to 66 °C)
SENSITIVITY	Senses capacitance as low as 0.15pF. May be decreased to approximately 1000pF.
TEMPERATURE STABILITY	Less than 1.0 pF typical (-40 °F to 150 °F).
ALARM TYPE	Low Acting: Alarm occurs upon absence of process material (unless otherwise specified).
ALARM ACTION	Fail Safe Alarm : Control relay de-energizes (drops out) upon alarm.
CONTROL RELAY CONTACTS	Two sets of form C contacts, rated at 5 amperes, 115 Vac or 26 Vdc, resistive load.
TIME DELAY	Standard delay is adjustable from 0 to 30 seconds. Standard mode is delay turn-on alarm. Consult the factory for other configurations.
DEAD BAND (L3545 Only)	Adjustable over range of 1.3pF for low values of process capacitance. Adjustment range increases up to approximately 1000pF, for high values of process capacitance.
STARTUP PUSH-BUTTON	Overrides normal control function when depressed (start/prime pump). After push-button is released, override continues for a period of time equal to pre-set delay time.
ELECTRONIC HOUSINGS - L3545	CONTROL UNIT: Structural foam, thermoplastic molded base and hinged cover. Weatherproof: NEMA 1-3, 3S, 4, 4X, 12, 13. SENSOR HEAD: Heavy-duty, cast aluminum. Explosion-proof for: Class I, Div. 1 & 2, Groups C & D; Class II, Div. 1, Groups E, F & G; Class III, Div. 1 & 2. Weatherproof: NEMA 7 CD, 9 EFG.
ELECTRONIC HOUSING -L3515	Heavy-duty, cast aluminum weatherproof housing for the following categories: Explosion-proof for: Class I, groups C & D; Class II, groups E, F & G. Weatherproof: NEMA 4



Stainless Steel Sensor Flange with Tri-Clamp



L3545 With Sensor Flange

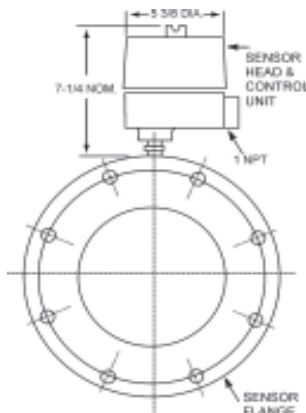

L3515 With Sensor Flange Outline Drawing

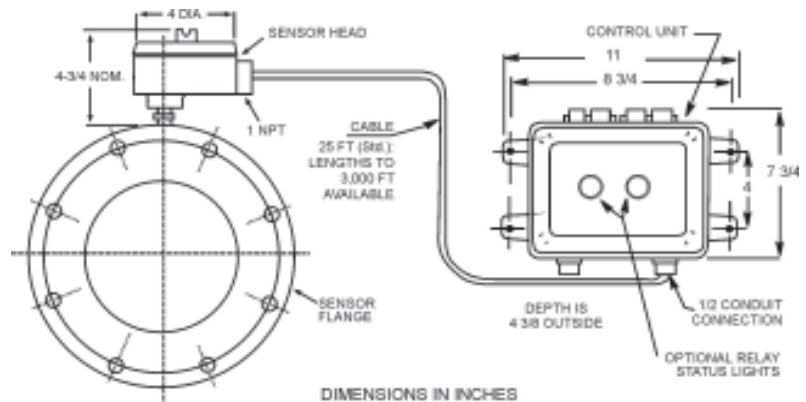

L3545 With Sensor Flange Outline Drawing

Models L3515 & L3545

L600 Series Sensor Flange Specifications

Model Number	Sensor Type	Wetted Surfaces	Connection
L631	Full-Ring	Epoxide, 316SS	Flanged
L632	Partial-Ring	Epoxide, 316SS	Flanged
L641	Full-Ring	Teflon, 316SS	Flanged
L642	Partial-Ring	Teflon, 316SS	Flanged
L651	Full-Ring	Epoxide, 316SS	Tri-Clamp
L652	Partial-Ring	Epoxide, 316SS	Tri-Clamp
L661	Full-Ring	Teflon, 316SS	Tri-Clamp
L662	Partial-Ring	Teflon, 316SS	Tri-Clamp

Pressure/Temperature Ratings	
Model Numbers	PSI @ °F
L631*, L632* L651*, L652*	200 @ 100°F 50 @ 150°F 0 @ 200°F
L641, L642 L661, L662	200 @ 100°F 100 @ 200°F 0 @ 300°F

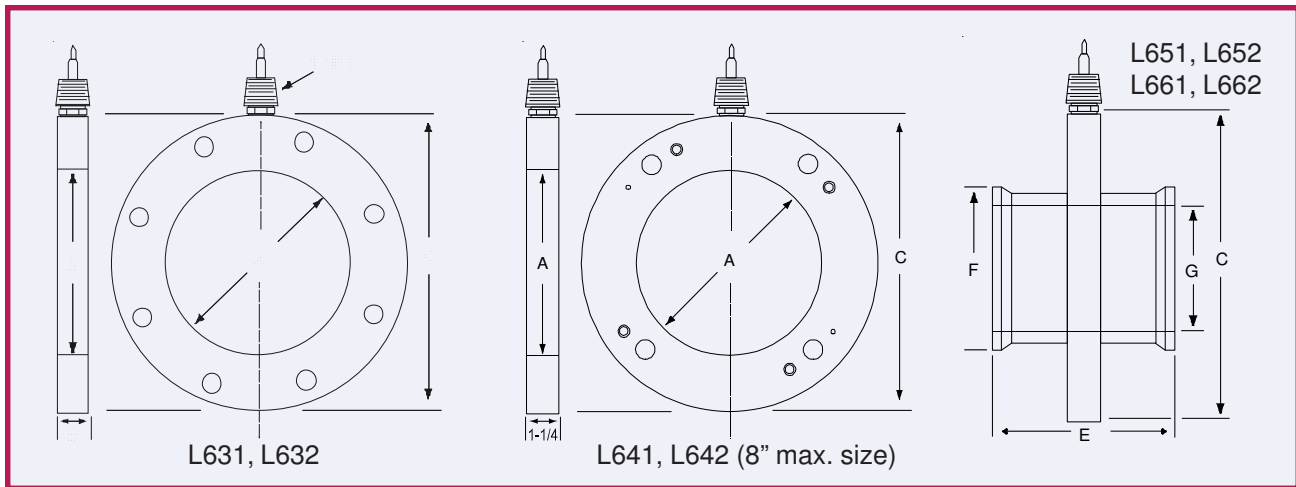

Flange Size	1	1-1/2	2	2-1/2	3	4	6	8	10	12
Part No. Suffix	10	15	20	25	30	40	60	80	100	120
Dim. A	1.05	1.61	2.07	2.47	3.07	4.03	6.06	7.98	10.02	12.00
Dim. B	5/8	5/8	11/16	3/4	13/16	7/8	15/16	1-1/16	1-1/8	1-1/8
Dim. C	4-1/4	5	6	7	7-1/2	9	11	13-1/2	16	19
Dim. L651/652	3-7/8	3-7/8	4-1/8	4-1/8	4-1/4	4-7/8	-	-	-	-
L661/662	3-3/4	3-3/4	4	4	4-1/8	4-3/4	-	-	-	-
Dim. F	1-31/64	1-31/64	2-23/64	3-3/64	3-37/64	4-11/16	-	-	-	-
Dim. G	7/8	1-3/8	1-7/8	2-3/8	2-7/8	3-7/8	-	-	-	-
Bolt Circle Dia	3-1/8	3-7/8	4-3/4	5-1/2	6	7-1/2	9-1/2	11-3/4	14-1/4	17
No. of Holes	4	4	4	4	4	8	8	8	12	12
Bolt Hole Dia.	5/8	5/8	3/4	3/4	3/4	7/8	7/8	7/8	1	1

Notes:

- Princo flanges are designed to interface with flat-faced flanges.
- Dimension A based on inside diameter of schedule 40 pipe.
- Ordering Example: A sensor flange of L632 type for use in a 3-inch pipe is specified as L632-30.
- All dimensions in inches.

10 Year Warranty

All PRINCO RF impedance level control instruments are backed by a 10-year warranty. PRINCO will repair or replace, at our option, any instrument that fails under normal use up to 10 years after purchase.