

# Precision Load Cells

**Series 85040 and 85070  
for compressive load, for tensile and  
compressive forces**

Code:	85040 EN
Delivery:	12 weeks / ex stock
Warranty:	24 months



**Model 85043 / Model 85073**



**Model 85041 / Model 85075**

- Measuring ranges from 0 ... 20 N to 0 ... 2 MN
- For static and dynamic forces
- High linearity from  $\pm 0.1$  % F.S.
- Very low sensitivity to lateral forces
- Models 85073 / 85075 suitable for extremely high dynamic stress, series 85070 up to  $10^9$  load cycles
- Extended temperature compensation range -55 °C to 120 °C (optional)
- Protection class IP68 (optional)

## Application

These load cells feature an outstanding ability to withstand static and dynamic stress and have exceptional precision and service life. These products have a huge range of applications in industry, R+D and testing thanks to the optional IP68 degree of protection and low sensitivity to lateral forces.

Examples of applications would be the measurement of:

- ▶ Insertion forces
- ▶ Reference measurement
- ▶ Weights (e.g. silos, skips)
- ▶ Tensile forces (tension in cables, chains etc. with load centering plate)
- ▶ Materials testing

For the compressive force sensors (models 85043 and 85073) the force must be applied through a plane plate, hard enough for the range of forces being measured, or a piston.

## Description

The force-sensitive diaphragm with fitted strain gauges is located between the central part, where the force is applied (force application), and the outer ring (containing fixing holes).

Two support diaphragms are additionally fitted, above and below the actual measuring element, to desensitize the sensors to extraneous lateral forces or moments. (see „Permitted external forces“ on page 2).

Models 85041/85075 (tension/compression) are calibrated in the tensile direction. The characteristic figure for the compression direction can nominally vary by  $\pm 0.25$  % from the figure for the tensile direction. The output signal is positive when the applied force is tensile.

The 8507X series (models 85073 and 85075) is designed for the highest possible dynamic stress and service life. This is  $> 10^9$  cycles from zero up to the full value of the measuring range in the tensile or compressive direction and tolerates a maximum operational force of up to 200 % of the nominal range.

## Dimensions

### Compressive load cell model 85043 - for static and dynamic operations

Order Code	Measurement Range	Dimensions [mm]												Number of Holes in $\phi$ G	Natural Frequency [kHz]
		$\phi$ D1	$\phi$ D2*	$\phi$ D3*	H	A	B	C	E*	$\phi$ G	$\phi$ X	$\phi$ Y	Z		
85043-0.02	0 ... 20 N	63.5	9.4	43.2	20.3	52.6	19	31.8	0.5	50.8	4.5	8.0	4.6	6	2
85043-0.05	0 ... 50 N	63.5	9.4	43.2	20.3	52.6	19	31.8	0.5	50.8	4.5	8.0	4.6	6	2
85043-0.1	0 ... 100 N	63.5	9.4	43.2	20.3	52.6	19	31.8	0.5	50.8	4.5	8.0	4.6	6	2
85043-0.2	0 ... 200 N	76.2	14.2	46.0	25.4	58.9	19	31.8	1.0	57.2	6.6	11.0	6.8	6	4.5
85043-0.5	0 ... 500 N	76.2	14.2	46.0	25.4	58.9	19	31.8	1.0	57.2	6.6	11.0	6.8	6	4.5
85043-1	0 ... 1 kN	76.2	14.2	46.0	25.4	58.9	19	31.8	1.0	57.2	6.6	11.0	6.8	6	4.5
85043-2	0 ... 2 kN	76.2	14.2	46.0	25.4	58.9	19	31.8	1.0	57.2	6.6	11.0	6.8	6	4.5
85043-5	0 ... 5 kN	76.2	14.2	46.0	25.4	58.9	19	31.8	1.0	57.2	6.6	11.0	6.8	6	4.5
85043-10	0 ... 10 kN	88.9	17.5	52.3	25.4	65.3	19	31.8	1.3	66.7	9.0	15.0	9.0	6	11
85043-20	0 ... 20 kN	88.9	17.5	52.3	25.4	65.3	19	31.8	1.3	66.7	9.0	15.0	9.0	6	11
85043-50	0 ... 50 kN	114.3	38.1	80.5	46.2	88.9	39	50.8	2.5	96.3	11.0	17.0	11.0	3	9
85043-100	0 ... 100 kN	114.3	38.1	80.5	46.2	88.9	39	50.8	2.5	96.3	11.0	17.0	11.0	3	9
85043-200	0 ... 200 kN	114.3	38.1	80.5	46.2	88.9	39	50.8	2.5	96.3	11.0	17.0	11.0	3	13
85043-500	0 ... 500 kN	114.3	38.1	80.5	46.2	88.9	39	50.8	2.5	96.3	11.0	17.0	11.0	3	13
85043-1 MN	0 ... 1 MN	139.7	50.8	98.4	50.8	101.6	39	50.8	2.5	122.2	11.0	17.0	11.0	3	11
85043-1.5 MN	0 ... 1.5 MN	190.5	63.5	143.0	63.5	127.0	39	50.8	2.5	171.5	11.0	17.0	11.0	3	10
85043-2 MN	0 ... 2 MN	279.4	120.7	203.1	109.7	171.5	39	50.8	2.5	241.3	11.0	17.0	11.0	3	8.4

### Compressive load cell sensor model 85073 - also suitable for highest dynamic operations

Order Code	Measurement Range	Dimensions [mm]												Number of Holes in $\phi$ G	Natural Frequency [kHz]
		$\phi$ D1	$\phi$ D2*	$\phi$ D3*	H	A	B	C	E*	$\phi$ G	$\phi$ X	$\phi$ Y	Z		
85073-0.02	0 ... 200 N	76.2	14.2	46.0	25.4	58.9	19	31.8	1.3	57.2	6.6	11.0	6.8	6	4.4
85073-0.05	0 ... 500 N	76.2	14.2	46.0	25.4	58.9	19	31.8	1.3	57.2	6.6	11.0	6.8	6	4.4
85073-1	0 ... 1 kN	76.2	14.2	46.0	25.4	58.9	19	31.8	1.3	57.2	6.6	11.0	6.8	6	4.4
85073-2	0 ... 2 kN	76.2	14.2	46.0	25.4	58.9	19	31.8	1.3	57.2	6.6	11.0	6.8	6	9.3
85073-5	0 ... 5 kN	88.9	17.5	52.3	25.4	65.3	19	31.8	0.8	66.5	9.0	15.0	9.0	6	9.3
85073-10	0 ... 10 kN	88.9	17.5	52.3	25.4	65.3	19	31.8	0.8	66.5	9.0	15.0	9.0	6	9.3
85073-20	0 ... 20 kN	114.3	38.1	75.9	46.2	88.9	39	50.8	2.5	96.3	11.0	17.0	11.0	3	5.9
85073-50	0 ... 50 kN	114.3	38.1	75.9	46.2	88.9	39	50.8	2.5	96.3	11.0	17.0	11.0	3	5.9
85073-100	0 ... 100 kN	114.3	38.1	75.9	46.2	88.9	39	50.8	2.5	96.3	11.0	17.0	11.0	3	5.9
85073-200	0 ... 200 kN	114.3	38.1	75.9	46.2	88.9	39	50.8	2.5	96.3	11.0	17.0	11.0	3	5.3
85073-500	0 ... 500 kN	139.7	50.8	104.9	50.8	101.6	39	50.8	2.5	122.2	11.0	17.0	11.0	3	
85073-1000	0 ... 1000 kN	190.5	63.5	139.7	63.5	127.0	39	50.8	2.5	171.5	11.0	17.0	11.0	3	

### Dimensional drawings models 85043 and 85073 from 50 kN

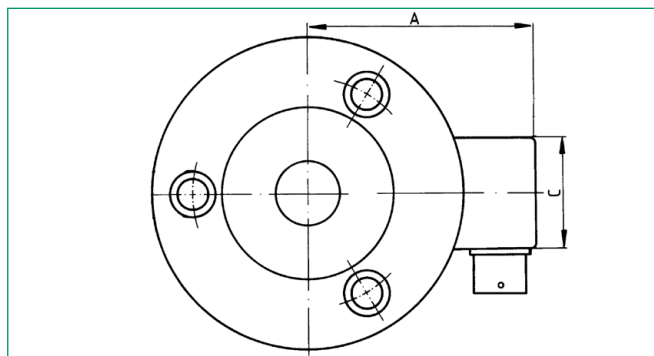
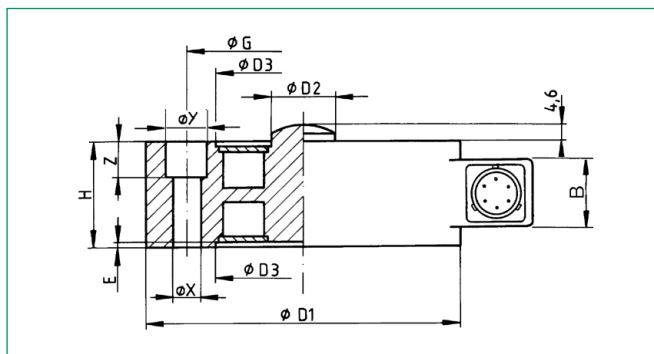

### Permitted external forces

As a result of the two stabilizing membranes with which these load cells have been designed, they only have very low sensitivity to forces that do not act centrally on the sensor. The effect of these undesirable external forces cannot be expressed in blanket figures; it depends on the sensor's range of measurement and also on the side from which the forces act. As a rule of thumb, it can be said that the contribution of the effect of external forces to the measuring signal, provided it is kept within the range of forces listed in the table below, is between 0.25 % and 1 % of the measuring range.

The table lists how large the external forces may be, expressed as a percentage of the load cell measuring range. The total of all the stresses acting on the load cell (forces and torques) should not exceed 100% of the measuring range. The forces quoted for the torques assume a distance of 2.5 cm from the point of action of the force.

End of Measurement Range	Shear Force (Lateral Force)	Bending Torque (Bending Force)	Torsion
up to	[% F.S.]	[% F.S.]	[% F.S.]
2 kN	50	40	25
10 kN	30	25	25
100 kN	20	20	15
500 kN	20	20	10

## Dimensions

### Tensile and compressive load cell model 85041 - for static and dynamic operations

Order Code	Measurement Range	Dimensions [mm]												Thread T	Number of Holes in $\varnothing$ G	Natural Frequency [kHz]
		$\varnothing$ D1	$\varnothing$ D2*	$\varnothing$ D3*	H	A	B	C	E*	$\varnothing$ G	$\varnothing$ X	$\varnothing$ Y	Z			
85041-0.02	0 ... 20 N	63.5	9.4	43.2	20.3	52.6	19	31.8	0.5	50.8	4.5	8.0	4.6	M 6 x 1.0	6	
85041-0.05	0 ... 50 N	63.5	9.4	43.2	20.3	52.6	19	31.8	0.5	50.8	4.5	8.0	4.6	M 6 x 1.0	6	
85041-0.1	0 ... 100 N	63.5	9.4	43.2	20.3	52.6	19	31.8	0.5	50.8	4.5	8.0	4.6	M 6 x 1.0	6	
85041-0.2	0 ... 200 N	76.2	14.2	46.0	25.4	58.9	19	31.8	1.0	57.2	6.6	11.0	6.8	M 10 x 1.0	6	
85041-0.5	0 ... 500 N	76.2	14.2	46.0	25.4	58.9	19	31.8	1.0	57.2	6.6	11.0	6.8	M 10 x 1.0	6	
85041-1	0 ... 1 kN	76.2	14.2	46.0	25.4	58.9	19	31.8	1.0	57.2	6.6	11.0	6.8	M 10 x 1.0	6	2
85041-2	0 ... 2 kN	76.2	14.2	46.0	25.4	58.9	19	31.8	1.0	57.2	6.6	11.0	6.8	M 10 x 1.0	6	
85041-5	0 ... 5 kN	76.2	14.2	46.0	25.4	58.9	19	31.8	1.0	57.2	6.6	11.0	6.8	M 10 x 1.0	6	
85041-10	0 ... 10 kN	88.9	17.5	52.3	25.4	65.3	19	31.8	1.0	66.7	9.0	15.0	9.0	M 12 x 1.5	6	4
85041-20	0 ... 20 kN	88.9	17.5	52.3	25.4	65.3	19	31.8	1.0	66.7	9.0	15.0	9.0	M 12 x 1.5	6	
85041-50	0 ... 50 kN	139.7	48.3	95.3	45.7	101.6	39	50.8	2.5	114.3	11.0	18.0	11.0	M 24 x 1.5	8	4
85041-100	0 ... 100 kN	152.4	58.9	105.9	45.7	108.0	39	50.8	2.5	123.8	13.5	-	-	M 36 x 3.0	8	20
85041-200	0 ... 200 kN	152.4	58.9	105.9	45.7	108.0	39	50.8	2.5	123.8	13.5	-	-	M 36 x 3.0	8	
85041-500	0 ... 500 kN	228.6	115.5	165.0	63.5	146.1	39	50.8	2.5	196.5	17.5	-	-	M 64 x 2.0	12	
85041-7001	0 ... 1 MN	279.4	136.9	203.1	76.2	171.5	39	50.8	2.5	241.3	26.0	-	-	M 64 x 2.0	12	
85041-7002	0 ... 2 MN	355.6	160.8	254.0	108.0	241.3	39	63.5	2.5	298.5	26.0	-	-	M 90 x 4.0	12	

\* These values are nominal values

### Tensile and compressive load cell model 85075 - also suitable for high dynamic operations

Order Code	Measurement Range	Dimensions [mm]												Thread T	Number of Holes in $\varnothing$ G	Natural Frequency [kHz]
		$\varnothing$ D1	$\varnothing$ D2*	$\varnothing$ D3*	H	A	B	C	E*	$\varnothing$ G	$\varnothing$ X	$\varnothing$ Y	Z			
85075-0.2	0 ... 200 N	76.2	14.2	46.0	25.4	58.9	19	31.8	1.3	57.2	6.6	11.0	6.8	M 10 x 1.0	6	4.4
85075-0.5	0 ... 500 N	76.2	14.2	46.0	25.4	58.9	19	31.8	1.3	57.2	6.6	11.0	6.8	M 10 x 1.0	6	4.4
85075-1	0 ... 1 kN	76.2	14.2	46.0	25.4	58.9	19	31.8	1.3	57.2	6.6	11.0	6.8	M 10 x 1.0	6	4.4
85075-2	0 ... 2 kN	76.2	14.2	46.0	25.4	58.9	19	31.8	1.3	57.2	6.6	11.0	6.8	M 10 x 1.0	6	9.3
85075-5	0 ... 5 kN	88.9	17.5	52.3	25.4	65.3	19	31.8	2.3	66.7	9.0	15.0	9.0	M 12 x 1.5	6	9.3
85075-10	0 ... 10 kN	88.9	17.5	52.3	25.4	65.3	19	31.8	2.3	66.7	9.0	15.0	9.0	M 12 x 1.5	6	9.3
85075-20	0 ... 20 kN	139.7	48.3	95.3	45.7	101.6	39	50.8	2.5	114.3	11.0	18.0	11.0	M 24 x 1.5	8	5.9
85075-50	0 ... 50 kN	152.4	59.2	106.2	45.7	108.0	39	50.8	2.5	123.8	13.5	-	-	M 36 x 3.0	8	5.9
85075-100	0 ... 100 kN	152.4	59.2	106.2	45.7	108.0	39	50.8	2.5	123.8	13.5	-	-	M 36 x 3.0	8	5.9
85075-200	0 ... 200 kN	190.5	78.2	125.2	50.8	127.0	39	50.8	2.5	152.4	22.0	-	-	M 52 x 3.0	8	5.3
85075-500	0 ... 500 kN	228.6	115.5	165.0	76.2	133.4	39	50.8	2.5	196.9	26.0	-	-	M 64 x 2.0	12	

\* These values are nominal values

### Dimensional drawing models 85041 and 85075 as well as 85041 and 85043 to 20 kN

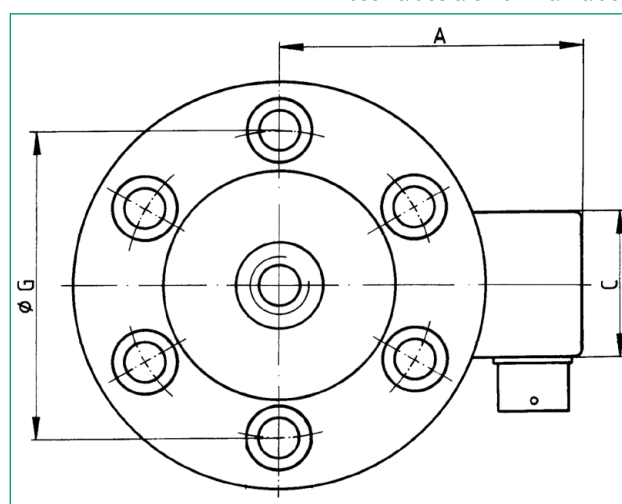
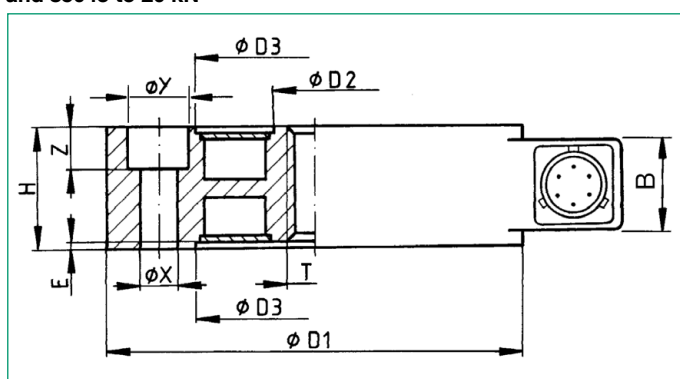

#### Notes:

1. A hole in the mounting surface allows force to be applied from below. If the sensor is mounted on a surface that has not been drilled, it is necessary to ensure that the threaded bolt that is screwed in from above does not press on the mounting face. This would cause a permanent error in measurements, or even damage the sensor.
2. Sensors for the measuring ranges 50 kN or 100 kN and above do not have counter-bored holes (see table, columns  $\varnothing$ Y and Z).

## Technical Data

### Electrical values

Bridge resistance: full bridge (foil strain gauges)	350 $\Omega$ , nominal <sup>1</sup>
Calibration resistor:	59 k $\Omega$ $\pm$ 0.1 %
The bridge output voltage caused by a shunt of this value is given in the calibration protocol.	
Excitation voltage:	recommended 10 V DC or AC maximum 15 V DC or AC

Nominal value:	2 mV/V, nominal <sup>1</sup>
Models 85041/85043, > 100 N:	3 mV/V, nominal <sup>1</sup>
Isolation resistance:	> 10 <sup>9</sup> $\Omega$ at 50 VDC

<sup>1</sup>) Deviations from the stated value are possible.

### Environmental conditions

Range of operation temperature:	- 55 °C ... 120 °C
Range of nominal temperature (compensated range):	15 °C ... 70 °C
Influence of temperature in the range of nominal temperature:	
to zero signal	$\pm$ 0.004 % F.S./K
to characteristics	+ 0.004 % Rdg./K

### Mechanical values

#### Models 85041 and 85043

Non-linearity:	
measurement range $\leq$ 0 ... 100 N	< $\pm$ 0.2 % F.S.
measurement range $\leq$ 0 ... 200 kN	< $\pm$ 0.1 % F.S.
measurement range $\geq$ 0 ... 500 kN	< $\pm$ 0.2 % F.S.

Hysteresis:	
measurement range $\leq$ 0 ... 100 N	< $\pm$ 0.1 % F.S.
measurement range $\leq$ 0 ... 200 kN	< $\pm$ 0.08 % F.S.
measurement range $\geq$ 0 ... 500 kN	< $\pm$ 0.2 % F.S.

Spread at unchanged installation position:	
measurement range $\leq$ 0 ... 100 N	< $\pm$ 0.1 % F.S.
measurement range $\geq$ 0 ... 200 N	< $\pm$ 0.03 % F.S.

Operational force: 150 % of nominal load

Maximum dynamic force:	
recommended	between 50 % and 70 % of nominal load
possible	100 % of nominal load

Deflection full scale: < 80  $\mu$ m

Material:	
stainless steel 17-4 PH	(similar to material 1.4542)
only model 85041 range $\geq$ 0 ... 1.5 MN	coated steel 4340 (similar to material 1.7707)

Protection class: according EN 60529 IP64  
IP 68 (refer to option)

Electrical connection:	
range $\leq$ 0 ... 20 kN:	6 pin bajonett plug-in connector mating connector model 9945 in scope of delivery
range $\geq$ 0 ... 50 kN:	6 pin screw connector mating connector model 9946 in scope of delivery

#### Models 85073 and 85075

Non-linearity:	< $\pm$ 0.1 % F.S.
Relative hysteresis:	< $\pm$ 0.1 % F.S.
Relative spread at unchanged installation position:	< $\pm$ 0.03 % F.S.
Operational force:	200 % of nominal force
Maximum dynamic load:	100 % of nominal force
Deflection full scale:	approx. 50 $\mu$ m ... 100 $\mu$ m
Material: stainless steel 17-4 PH	(similar to material 1.4542)
Protection class:	accord. EN 60529 IP64 IP68 (refer to option)

Electrical connection:	
Range $\leq$ 0 ... 10 kN:	6 pin bajonett plug-in connector mating connector model 9945 in scope of delivery
Range $\geq$ 0 ... 20 kN:	6 pin screw connector mating connector model 9946 in scope of delivery

#### Models 85041 and 85075

Bolts with a strength class of at least 10.9 should be used to mount these tensile and compression load cells. The preference direction is that of tension. The output signal is positive when the applied force is tensile.

#### All models

Wiring (standard):			
pin A + B	excitation	positive	
pin C + D	excitation	negative	
pin E	output	negative	
pin F	output	positive	

#### Label

The label at sensor's surface has a height of approximately 0.5 mm.

## Order Information

Precision load cell for compressive loads,  
 measurement range 0 ... 200 N **Model 85073-0,2**

Precision load cell for tensile and compressive loads,  
 extended range of nominal temperature - 55 °C ... 120 °C,  
 measurement range 0 ... 100 kN **Model 85041-6100-V010000**

## Accessories

Mating connector (cable coupling), in scope of delivery with the sensor

#### Model 85041 und 85043

6 pin bajonett connector (to 20 kN) **Model 9945**  
 6 pin bajonett connector (from 50 kN) **Model 9946**

#### Model 85073 und 85075

6 pin bajonett connector (to 10 kN) **Model 9945**  
 6 pin bajonett connector (from 20 kN) **Model 9946**

#### Connection cable, length 3 m (one end open for soldering)

with coupling model 9945 **Model 9986**  
 with coupling model 9946 **Model 99546-000A-0150030**

#### Connection cable for burster desktop units, length 3 m

with coupling model 9945 and connector 9941 **Model 9911**  
 with coupling model 9946 and connector 9941 **Model 9912**

#### Connection cable for 9235 and 9310

with coupling model 9945 and connector 9900-V209 **Model 99209-545A-0160030**  
 with coupling model 9946 and connector 9900-V209 **Model 99209-546A-0160030**

## Load centering plate for models 85041 and 85075

The purpose of these plates is that for the second assembly reference point for the force application it is possible, rather than using the fastening holes (F around the circumference G) to again use a threaded bolt with an optimally central line of action. The diameters D1 to D3 and the thread T of the centering plate correspond to those of the associated sensor.

Dimensions and prices for the load centering plates are available on request.

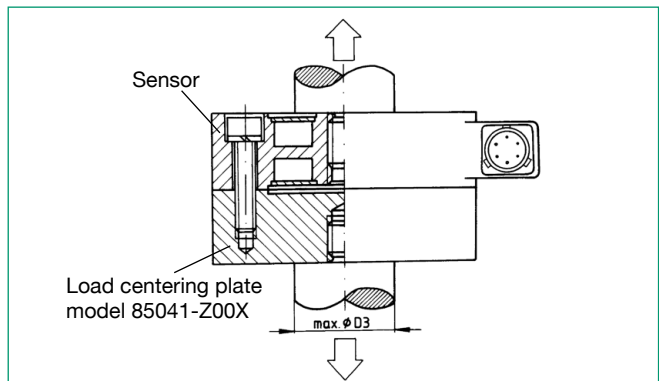

## Signal processing

Digital indicator like model 9180, amplifiers like model 9243, process measuring and control units like DIGIFORCE®  
**refer to section 9 of the catalog.**

## Reference measurement chain

Combined with the TRANS CAL 7281 it is the ideal tool for mobile calibration and adjustment of force-application equipment.

**refer to data sheet 7281 in section 7 of the catalog.**

## Options

Hermetically closed version, IP68, with waterproofed cable connection, length 3 m, usable up to 80 °C. (cannot be combined with the extended measurement temperature range) **...-VxxxIxx**

Range of nominal temperature (compensated range) extended to - 55 °C ... 120 °C (cannot be combined with IP68) **...-VxIxxxx**

## Factory Calibration Certificate (WKS)

Calibration of a load cell separately as well as connected to an indicator. Standard is a certificate with 11 points, starting at zero, running up and down in 20% increments covering the complete measuring range for preferential direction. Special calibrations on request. Calculation of costs by base price plus additional costs per point.

**Order Code 85WKS-85...**