

Position Transducers potentiometric up to 900 mm, IP55

Series LWH

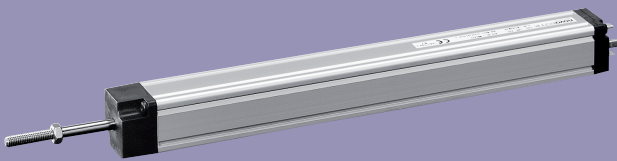

Special features

- very long life - up to 100 million movements, depending on application
- outstanding linearity - up to $\pm 0.04\%$
- high resolution - 0.01 mm
- very high operating speed
- connection via plug and socket to DIN 43650 (hydraulic connector)
- protection class IP 55

LWH transducers are designed for the direct, absolute measurement of displacement or length in control regulation and measuring applications.

High resolution (0.01 mm) combined with a stroke length of up to 900 mm permits the accurate measurement of linear displacement.

Rack and pinions or similar devices are not required because the design of the transducers is such that they may be integrated directly into the mechanical system.

Tight tolerances on the extruded body, combined with a special surface treatment, permit high operating speeds and reduced wear. A pivoting front bearing overcomes "stickslip" operation even with some angular or out-of-parallel misalignment.

The Novotechnik design for connections to the resistance track ensures the highest degree of reliability, even under harsh working conditions.

The transducer has mounting grooves on all four housing surfaces. Thus the transducer can always be mounted in the preferred orientation, with the resistance element directed upwards, independent of the mounting surface.

Difficult to reach overhead mounting is simplified by pre-mounting the included clamps, then simply snap-mounting the transducer into place.

Description	
Housing	aluminium, anodized
Mounting	adjustable clamps, snap in on all sides
Actuator	stainless steel (1.4305), rotatable, external thread M6
Bearings	pivoting sleeve bearing
Resistance element	conductive plastic
Wiper assembly	precious metal multi-finger wiper, elastomer-damped
Electrical connections	4-pin plug socket to DIN 43650

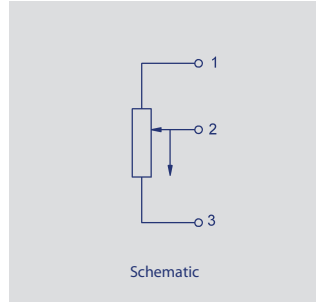
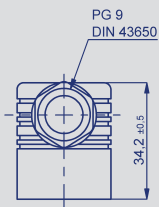
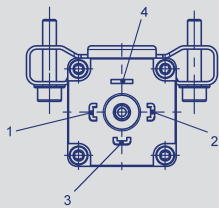
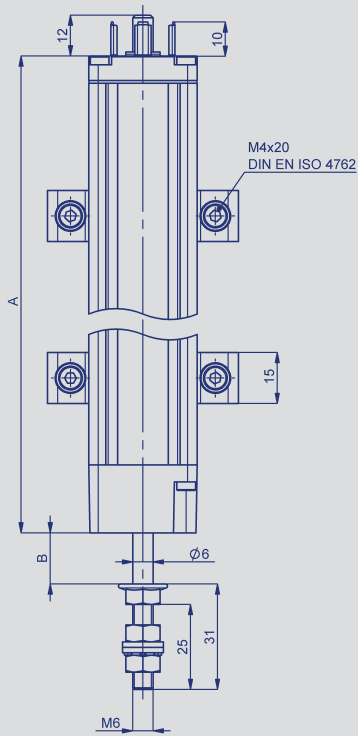
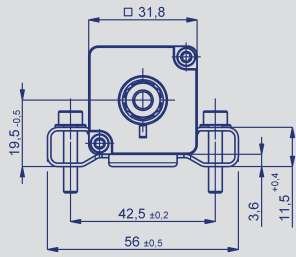

Type designations	LWH 0075	LWH 0100	LWH 0130	LWH 0150	LWH 0175	LWH 0200	LWH 0225	LWH 0250	LWH 0275	LWH 0300	LWH 0325	LWH 0360	LWH 0375	LWH 0400	LWH 0450	LWH 0500	LWH 0550	LWH 0600	LWH 0750	LWH 0900	
Electrical Data																					
Defined electrical range	75	100	130	150	175	200	225	250	275	300	325	360	375	400	450	500	550	600	750	900	mm
Electrical stroke	77	102	132	152	178	203	228	254	279	304	330	366	381	406	457	508	559	610	762	914	mm
Nominal resistance	3	3	3	5	5	5	5	5	5	5	5	5	5	5	5	5	5	5	10	10	kΩ
Resistance tolerance	20																				±%
Independent linearity	0.1	0.1	0.09	0.08	0.07	0.07	0.07	0.07	0.07	0.06	0.05	0.05	0.05	0.05	0.05	0.05	0.05	0.05	0.04	0.04	±%
Repeatability	0.01																				mm
Recommended operating wiper current	≤ 1																				µA
Maximum permissible wiper current (in case of system failure)	10																				mA
Maximum permissible applied voltage	42																				V
Effective temperature coefficient of the output-to-applied voltage ratio	typical 5																				ppm/K
Insulation resistance (500 VDC)	≥ 10																				MΩ
Dielectric strength (500 VAC, 50 Hz)	≤ 100																				µA
Mechanical Data																					
Body length (dimension A)	146	171	201	222	248	273	298	324	349	375	400	436	451	476	527	578	629	680	832	984	±2 mm
Mechanical stroke (dimension B)	85	110	140	161	186	212	237	262	288	313	339	374	390	415	466	516	567	618	770	923	±2 mm
Total weight	220	250	290	320	350	380	410	440	470	500	530	570	590	620	680	740	805	870	1050	1230	g
Weight of actuator and wiper	50	55	60	65	72	78	85	90	95	100	105	115	120	125	135	145	160	170	210	245	g
Operating force horizontal	< 10																				N
vertical	≤ 10																				N
Environmental Data																					
Temperature range	-30 ... +100																				°
Vibration	5...2000 Amax = 0.75 amax= 20																				Hz mm g
Shock	50 11																				g ms
Life	> 100 x 10 ⁶																				movem.
Operating speed	10																				m/s max.
Operational acceleration	200 (20 g)																				m/s ² max.
Protection class	IP55 (DIN EN 60529)																				

Novotechnik U.S., Inc.
 155 Northboro Road
 Southborough, MA 01772

Phone 508 485 2244
 Fax 508 485 2430
 info@novotechnik.com
 www.novotechnik.com

© 09/2012
 Subject to changes.

Order designations	
Type	P/N
LWH-0050*	024302
LWH-0075	024303
LWH-0100	024304
LWH-0110*	024360
LWH-0130	024305
LWH-0150	024306
LWH-0175	027307
LWH-0200	024308
LWH-0225	024309
LWH-0250	024310
LWH-0275	024311
LWH-0300	024312
LWH-0325	024313
LWH-0360	024314
LWH-0375	024315
LWH-0400	024316
LWH-0425*	024317
LWH-0450	024318
LWH-0500	024320
LWH-0550	024322
LWH-0600	024324
LWH-0650*	24326
LWH-0750	024330
LWH-0800*	024332
LWH-0900	024336

*) Technical data on request.
 Other lengths on request

Included in delivery

1 plug connector GDM 3009,
 (Ø 4,5 mm - 7 mm),
 1 sealing gasket GDM 3-16,
 2 fixing clamps with 4 screws

Optional accessories

Pivot head Z-60 with internal
 thread M6x12, P/N 058100.
 Process-controlled indicators
 MAP... with display.



Signal conditioner MUW...
 (integrated in plug connector)
 with supply voltage 24 V and
 voltage or current output
 signals.

Important

All values specified in this data
 sheet for linearity, lifetime and
 temperature coefficient are
 only valid for a sensor used as
 a voltage divider with virtually
 no load applied to the wiper
 ≤ 1 µA).