

Terminal Press Fitting

AC Servo Press CS/GS/MS Series



Ultimate Easy Use and Performance

AC Servo Press

CS Series
GS Series
MS Series

WPS Controller **NEW**

Applications

Press fitting (bearings, bushings, pins, and the like), staking, bending, forming, joining, punching, cutting, engraving, clamping, straightening, hot press, inspection, etc.

Stack compression, valve seat/guide press fitting, pressurized height measurement, bending of electric component terminals, long-term constant pressure, ultrasonic welding, heat welding, various testing (endurance test, and the like), etc.

Use Examples



C-Frame Type

4-Column Type

Desktop Type

Coretec can deliver servo presses of 2 to 200 kN with various specifications as well as peripheral electrical equipment.



Multiple-Shaft Synchronized Press

Pressure can be applied to large workpieces in an even manner by dispersing the pressurizing points. Please consult with Coretec for high thrust forces exceeding 200 kN.

AC Servo Related Products



C-Frame Multi Press

Allows you to start working right after connecting to a power source. No need to create operating programs.



Multi Controller

An all-in-one controller that provides completely free servo press operation. All electrical components, including the safety PLC, are housed in a compact enclosure.

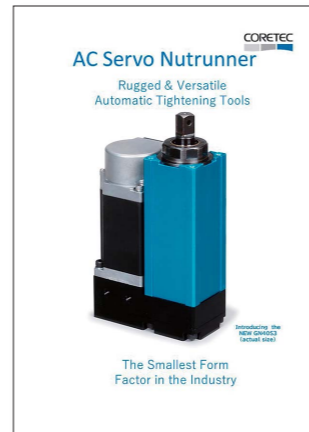

Nutrunner

Perfect for tightening high-precision parts in production lines. Compact, long life, and high rigidity.

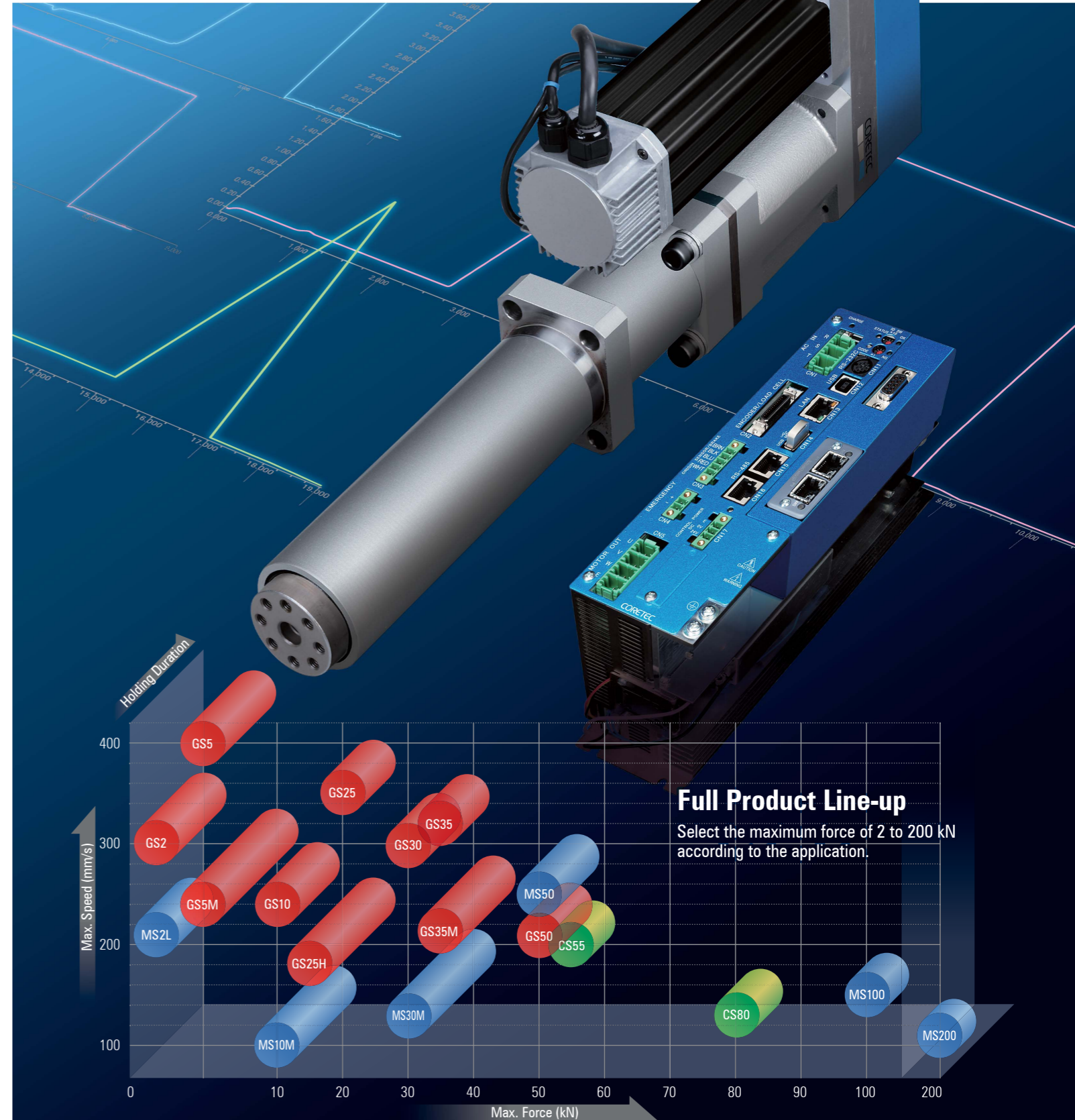

CORETEC is the brand logo of CORETEC's NB brand.



Presented by: Absolute Gauge Technologies
sales@absolute-gauge.com; www.absolute-gauge.com,
Toronto: 416 754 3168, Montreal: 514 695 5147, Toll Free: 1 888 754 7008

Coretec's "AC Servo Press System": Adopted for a Wide Range of Production Processes

AC Servo Press Tools

Fully enhanced lineup with addition of GS Series

- The GS Series is an advanced version of the CS Series, with a stronger motor for increased capacity and no origin sensor.
- The MS Series uses a Mitsubishi motor and amplifier. This is a high value-added model with large force, high load, and absolute specifications and is excellent in slow speed operation.
- The middle mounting flange structure provides high rigidity despite its slimness. Internal structure that allows pull operation (except MS200)
- Equipped with a load cell amplifier with a built-in microprocessor. Provided with tool ID function as well as a linearity correction function and tool operation history.

WPS Controller

Next-Generation controller with improved expandability, safety and convenience

- Inherits the features of previous generations of controllers while also adopting cutting-edge methods and features. This controller can also be used to control existing CS and MS tools being used.
- A compact controller has been added specifically for small tools. This enhances cost competitiveness.
- Two expansion slots are provided for connection to external devices. Optional circuit boards can be installed to support various types of communication and control.
- All types are equipped with a dedicated emergency stop input to ensure safety. This allows you to directly connect an emergency stop button.
- The use of non-volatile memory enables battery-free operation. This eliminates troublesome replacement procedures and enables easy transport.

Massive Improvement in Work Data Storage and Analysis Capabilities

Improved Data Collection and Analysis Capabilities

A maximum of 100,000 points*1 of data can be saved per waveform of operation results every 0.25 ms in the shortest*2.

A total of four waveforms can be selected and saved for tool speed, current load factor, load rate, and similar items as based on load and stroke.

Equipped with USB Memory

Enables saving of various data and history.

- Numeric/Waveform data
- Program archives
- Alarm record, etc.

Other functions

- Firmware updating



Scope Function

Up to eight types of specific data in the controller can be continuously transmitted to the PC side.

As it can continuously monitor data, it is expected to be used for analyzing rare phenomena and for IoT applications.

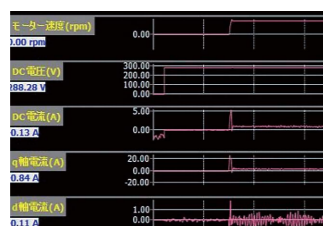

Load value, stroke value, tool speed, load change rate, motor current absolute value, DC voltage, PIN/POUT, program block, electronic thermal load rate, instantaneous load rate, mechanical brake status, origin sensor, external stroke, etc.

Servo Systems with Various Performance Enhancements

Thorough Pursuit of Basic Performance

A program execution cycle of 0.25 ms*3 provides even better responsiveness and repeatability.

Control by External Load Value and Stroke Value

Can control the tool by reading signals from external load cells and linear sensors.

In particular, control using an external linear encoder enables press operation with dramatically better positional accuracy while also using it as a high-precision measurement device. It is perfect for fields requiring high precision.

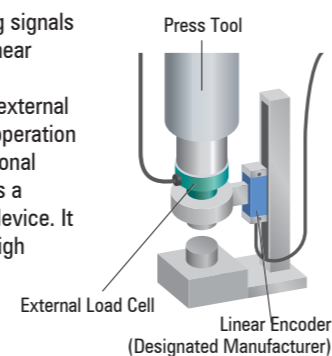

The load signal from the external load cell converted by the dedicated load cell amplifier is connected to the WPS controller via a standard cable. The stroke signal from the external linear encoder is connected to an optional circuit board of the WPS controller.

Great advancement of "Reliability" as well as "Performance"

The features of Coretec's products, such as

high-speed response

free operation

real-time judgment control

have been further refined.

Press System Designed to Pursue Ease of Use

Completed in All-in-One Application Software

One software package covers everything from tool operation to data collection, analysis and management for all servo tools of the CS/GS/MS Series. The software is available in multiple languages. There is also a full range of help functions to provide operability and ease of understanding beyond the instruction manual.

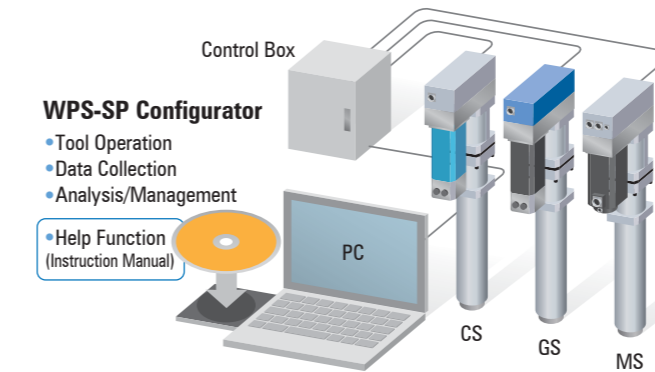

Work Explorer Function

Simply set the workpiece and enter a few parameters interactively to start the tool. The easiest and most realistic method to create a program, which finds the contact position with the workpiece and automatically generates an operating program, is available.

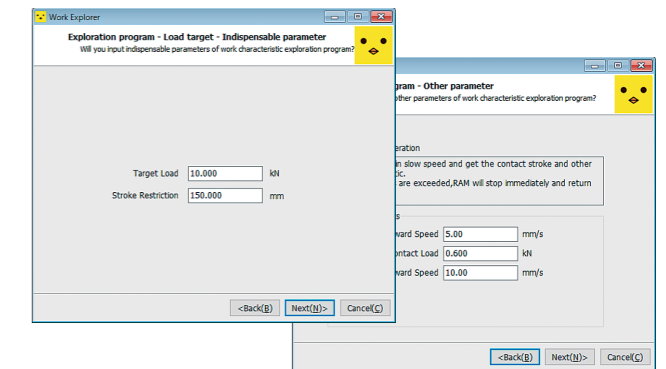

Easy-to-Understand Programming Methods

Programming methods include adoption of a "block method" that makes it easy to grasp the flow of operations and a "label method" that allows names to be attached to variable parts for ease of understanding.

The function for rewriting programs from the PLC has been inherited. Equipped with a function for converting programs from CPS to WPS style.

Main Body	Program Table	Judgement Table	Registers Label	Comment	
Block	Block Name	Step	Invalid Loop	Instruction	Parameter
01	Initial	1		Mechanical Brake	Off
		2		Data Save	Begin
		3		Stroke Limit+	Stroke Limit
		4			
02	Load Protection	1		Load<<	Protection Load
		2		Mul	Protection Load
		3		Load Limit	Protection Load
		4			

Programming Screen (Partial)

Operation Simulator

Software to verify press operation on a PC in advance is available. This enables customers to smoothly select and start up their tools.

Expanded Post-Operation Judgment Function

In addition to Coretec's characteristic real-time judgment function, we have added a post-operation judgment function that is processed internally by the controller after operation. In addition to standard zone and frame judgments, upper and lower limits can be judged using general numerical values.

Moreover, a new function to link with external judgment applications has also been added. This allows each customer to use their own preferred judgment methods. The internal and external judgment results are combined for a comprehensive pass/fail judgment.

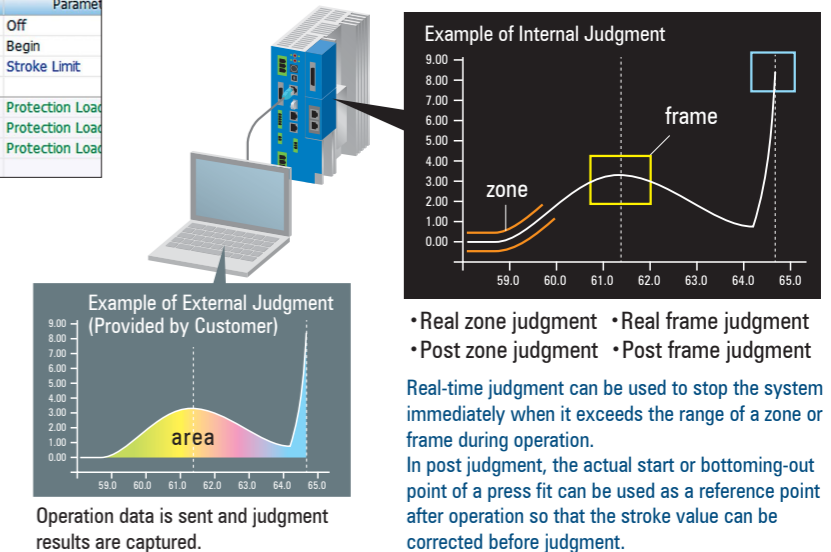

- Real zone judgment
- Real frame judgment
- Post zone judgment
- Post frame judgment

Real-time judgment can be used to stop the system immediately when it exceeds the range of a zone or frame during operation.

In post judgment, the actual start or bottoming-out point of a press fit can be used as a reference point after operation so that the stroke value can be corrected before judgment.

*1: 1,000 times that of our current products *2: Four times faster than our current products *3: Four times faster than our current products

AC Servo Press CS/GS Series

AC Servo Press MS Series

Specifications

Model	GS2	GS5	GS5M	GS10	GS25	GS25H	GS30	GS35	GS35M	GS50	CS55	CS80	MS2L	MS10M	MS30M	MS50	MS100	MS200	
Max. instantaneous force (kN)	2	5	5	10	25	30	35	35	50	55	80	2	10	30	50	100	200		
Applicable force (kN)*1	1.5	3	5	7	15	21	35	35	40	45	70	1.5	7	21	45	70	150		
Max. stroke (mm)	100	100/250		100/200/350			200/400		100/200/350			100	100/250	100/200/350			100/200		
Special stroke (mm)	200	150		400			400/500		-			400/500		400/500			300		
Max. speed (mm/s)*2	300	400	240		350	180	300	320	215		200	135	215	100	130	250	150	110	
Controller model	WPS-SP30 or WPS-SP75				WPS-SP75				WPS-MSJ4 + Amplifier										
Load cell accuracy	±1.5% @FS (Repeatability ±0.5% @FS)																		
Positional repeatability	0.01mm *3																		
Max. power supply capacity (kVA)	0.3	0.75		3.5			4.2		0.3	0.9	3.5	5.5	7.5	10					
Brake holding load (kN)	0.5	0.6	1		2.8	3.2	1.8		2.6	2.5		0.7	1.1	4.1	1.8	2.5	23.4		

*1: This is the applied force in consideration of the mechanical life. *2: Coretec recommends using CS and GS models at 75% or less of the maximum speed. A maximum press fitting speed of 30 mm/s is recommended for all models. *3: Under the same conditions * Please feel free to inquire about specifications for models not indicated above.

Dimensions

Model No.	A (mm)	B (mm)	C (mm)	D (mm)	Weight (kg)
GS2-100BK	162	262	108	48	3.5
GS5 (M)-100BK	335	466	150	65	13
GS5 (M)-250BK		671			18
GS10-100B		466			13
GS10-250BK		671			18
GS25 (H)-100BK	390	511	200	80	24
GS25 (H)-200BK		651			28
GS25 (H)-350BK		851			34
GS30-100BK	398	556	215	94	32
GS30-200BK		681			36
GS30-350BK		861			42
GS35 (M)-200BK		760			66
GS35 (M)-400BK	487	1000	260	118	82
GS50-200BK		760			66
GS50-400BK		1000			82
CS55-100BK		535			781
CS55-200BK	861		82		
CS55-350BK	1041		96		
CS80-100BK	781		76		
CS80-200BK	535	861	290	135	82
CS80-350BK		1041			96

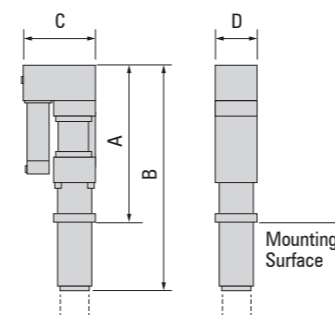

Model No.	A (mm)	B (mm)	C (mm)	D (mm)	Weight (kg)
MS2L-100BK	162	262	108	48	3.5
MS10M-100BK	335	466	152	65	13
MS10M-250BK		671			18
MS30M-100B	415	573	215	94	33
MS30M-200B		698			37
MS30M-350B		878			43
MS50-100BK	535	781	290	135	79
MS50-200BK		861			85
MS50-350BK		1041			99
MS100-100B		781			84
MS100-200B	535	861	290	135	90
MS100-350B		1041			104
MS200-100B	721	1146	451	228	170
MS200-200B		1246			184

Tool Model Notations

Series name **GS 35 M 400 B**
 CS,GS,MS
 Max. force (kN) 02,05,10,20,30,35,50,55,80,100,200 (Refer to the specifications)
 M: Load holding type
 B: With holding brake
 C: No load cell (MS200 only)
 K: No origin sensor
 A: Absolute type (MS series only)
 Max. stroke (mm) 100,200,250,350,400 (Refer to the specifications)

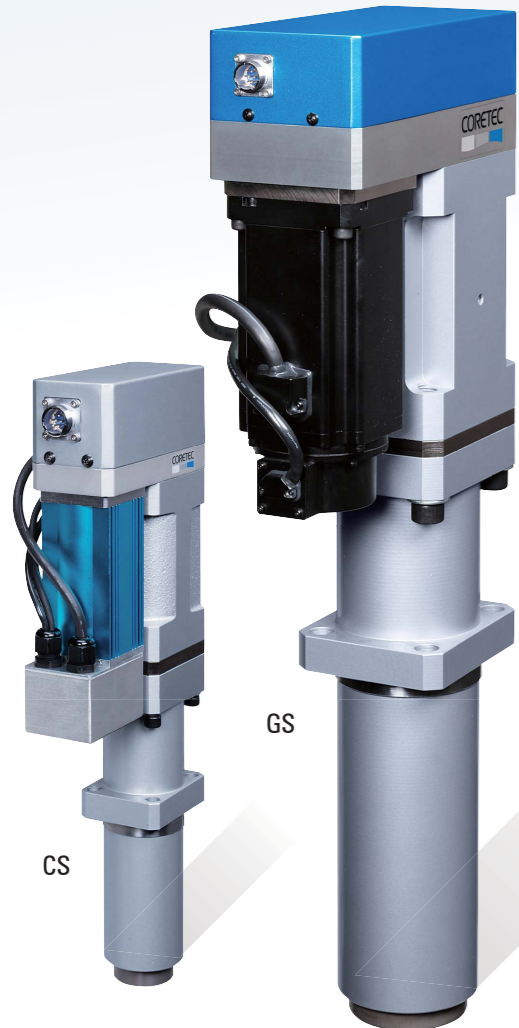

CS/GS System Configuration

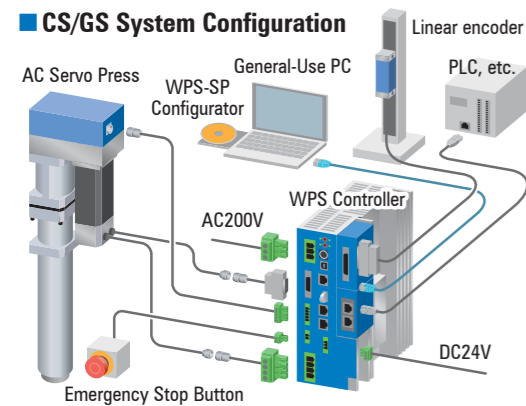

Equipped with two expansion slots for optional circuit boards. (All series)

WPS Controller

Controller Specifications

Product name	Compact controller	Standard controller	MSJ4 controller
Model	WPS-SP30	WPS-SP75	WPS-MSJ4
Control power	DC24V ±10%		
Operating power	3-phase 200-230V ±10% 50/60Hz		
Cooling method	Natural air cooling	Built-in fan forced air cooling	-
Regenerative function	-	80-W regenerative resistance	-
External size (mm)	65×180×242	75×190×242	51×110×230



Controller Model Notations

Indicates the hardware version
WPS-SP30 * * * * *
-SP75 * * * * *
-MSJ4 * * * * *
 Code indicating the optional circuit board of option slot 1
 Code indicating the optional circuit board of option slot 2

Optional Circuit Board	Code
Field bus	CCL
	DEV
Industrial-use Ethernet	PFN
	EIP
	CIF
P/I/O	NPN
	PNP
Linear encoder	LNE
Dedicated Ethernet circuit board	SET
Analog monitor	ANM



MS System Configuration

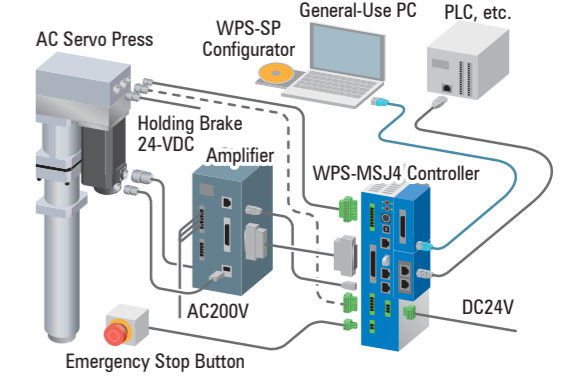

Equipped with two expansion slots for optional circuit boards. (All series)