

MR-Q7-1000LE-DI(CE)

Latent Mobile Robot



Key Feature

- Self-localization navigation: adopts inertial, 2D barcode, laser and visual SLAM navigation methods to achieve accurate positioning.
- Supports smooth motions like forward, backward, and rotation via dual-wheel differential drive.
- Smart power management: supports multi-level electrical threshold, auto-charge, and self-returning after charging completed.
- Multi-safety protection includes front laser obstacle avoidance, pneumatic bumper strip detection, emergency stop button, etc.
- Human-machine interaction: indicates the device status via touch screen, sound and indicators.
- Supports carrying, rotating, lifting and lowering goods up to 1000 kg (2204.62 lb.).
- Wireless communication: supports Wi-Fi and seamless roaming in a network covered area.

Typical Application

Automobile, consumer electronic, manufacturing, logistics, food, medicine, etc.

Available Model

MR-Q7-1000LE-DI(CE)

MR-Q7-1000CE-DI(CE)

MR-Q7-1000VE-DI(CE)

Accessory

Charging station model: MR-RA-CH-48/30B-CI(CE)



Appearance

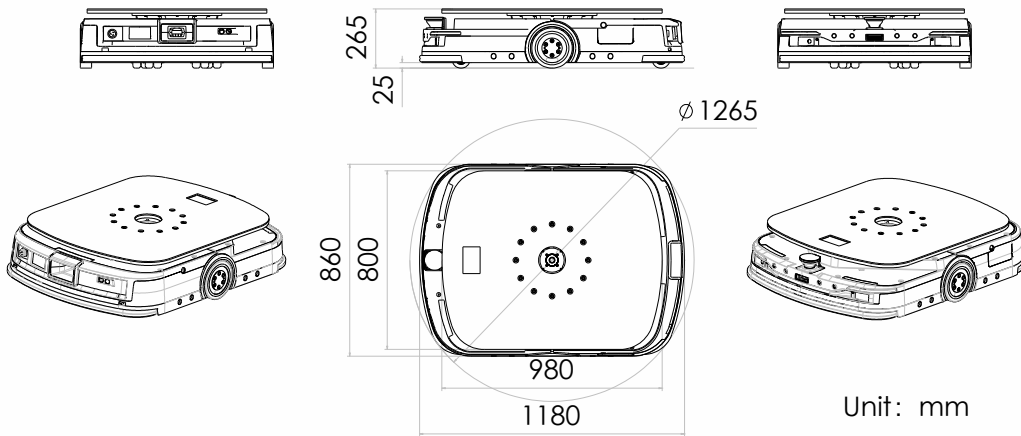

Charge Station Deployment

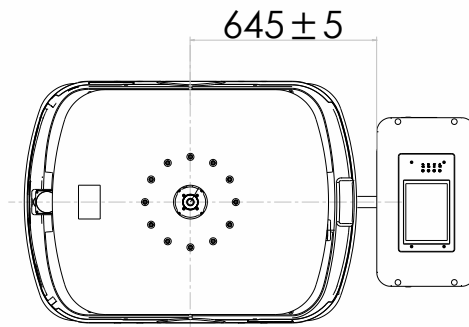

Specification

Model		MR-Q7-1000LE-DI(CE)	
Basic Parameter			
Dimension (L × W × H)		1180 mm × 860 mm × 265 mm (46.46" × 33.86" × 10.43")	
Rotation diameter		1265 mm (49.80")	
Chassis above the ground		25 mm (0.98")	
Lifting tray dimension		980 mm × 800 mm (38.58" × 31.50")	
Lifting height		60 mm (2.36")	
Lifting type		Electrically lifting	
Weight		247 kg (544.54 lb.)	
Rated load		1000 kg (2204.62 lb.)	
Navigation mode		Laser SLAM/2D barcode/Visual SLAM(ground texture)	
Human-machine interaction		Touch screen	
Safety Protection			
Front	Laser Obstacle Avoidance	Installation Height	195 mm (7.68")
		Scanning Angle	260°
		Max. Detection Range	20 m (787.40")
Rear	Infrared obstacle avoidance	Sensor Quantity	2
		Installation height	82 mm (3.23")
		Max. detection range	0.05 m to 5 m (1.97" to 196.85")
Side	Ultrasound obstacle avoidance	Sensor Quantity	One each on left and right
		Installation height	193 mm (7.60")
		Scanning Angle	Horizontal 80°, vertical 34°
		Max. Detection Range	0.2 m to 1 m (7.87" to 39.37")
Bumper Strip Detection		Front/Rear	
Emergency Stop Button		Front/Rear	
Radium Indicator		Support	
Motion Performance			
Rated running speed (empty)		1800 mm/s	
Rated running speed (rated load)		1500 mm/s	
Rated acceleration (empty)		1000 mm/s ²	
Rated acceleration (rated load)		500 mm/s ²	
Rotation speed (empty)		180°/s	
Rotation speed (rated load)		90°/s	
Gradeability		3°	
Location angle accuracy		± 1°	
Location accuracy		± 10 mm (± 0.39")	
Battery Performance			
Battery Type		LiFePO	
Rated Voltage		48 V	
Capacity		44 Ah	
Charge Cycle		1500 times (for fully charging and discharging)	
Run Time		8 h	
Charge Time		≤ 2 h (for fully charging and discharging)	