

PROPRIETARY AND CONFIDENTIAL

THE INFORMATION CONTAINED IN THIS DRAWING IS THE SOLE PROPERTY OF DYTRAN INSTRUMENTS INC. ANY REPRODUCTION IN PART OR AS A WHOLE WITHOUT THE WRITTEN PERMISSION OF DYTRAN INSTRUMENTS INC. IS PROHIBITED

MODEL	SENSITIVITY
3056D1	10 mV/g
3056D2	100 mV/g
3056D3	500 mV/g
3056D4	20 mV/g
3056D5	50 mV/g
3056D6	200 mV/g
3056D7	5 mV/g

REVISIONS					
REV.	ECN	DESCRIPTION	BY/DATE	CHK	APPR
A	11394	INITIAL RELEASE	RA, 11/06/14	EM	DV
B	11943	REVISED MARKING LOCATION, ADDED VIEW A-A	RA, 05/05/15	MH	LN

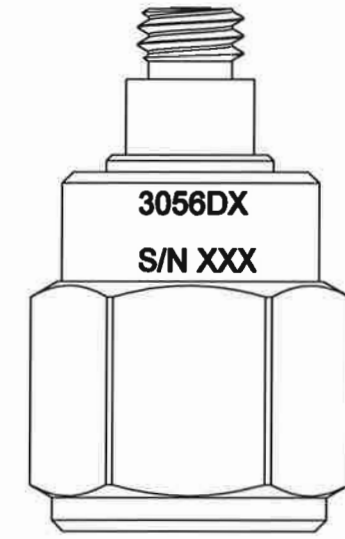
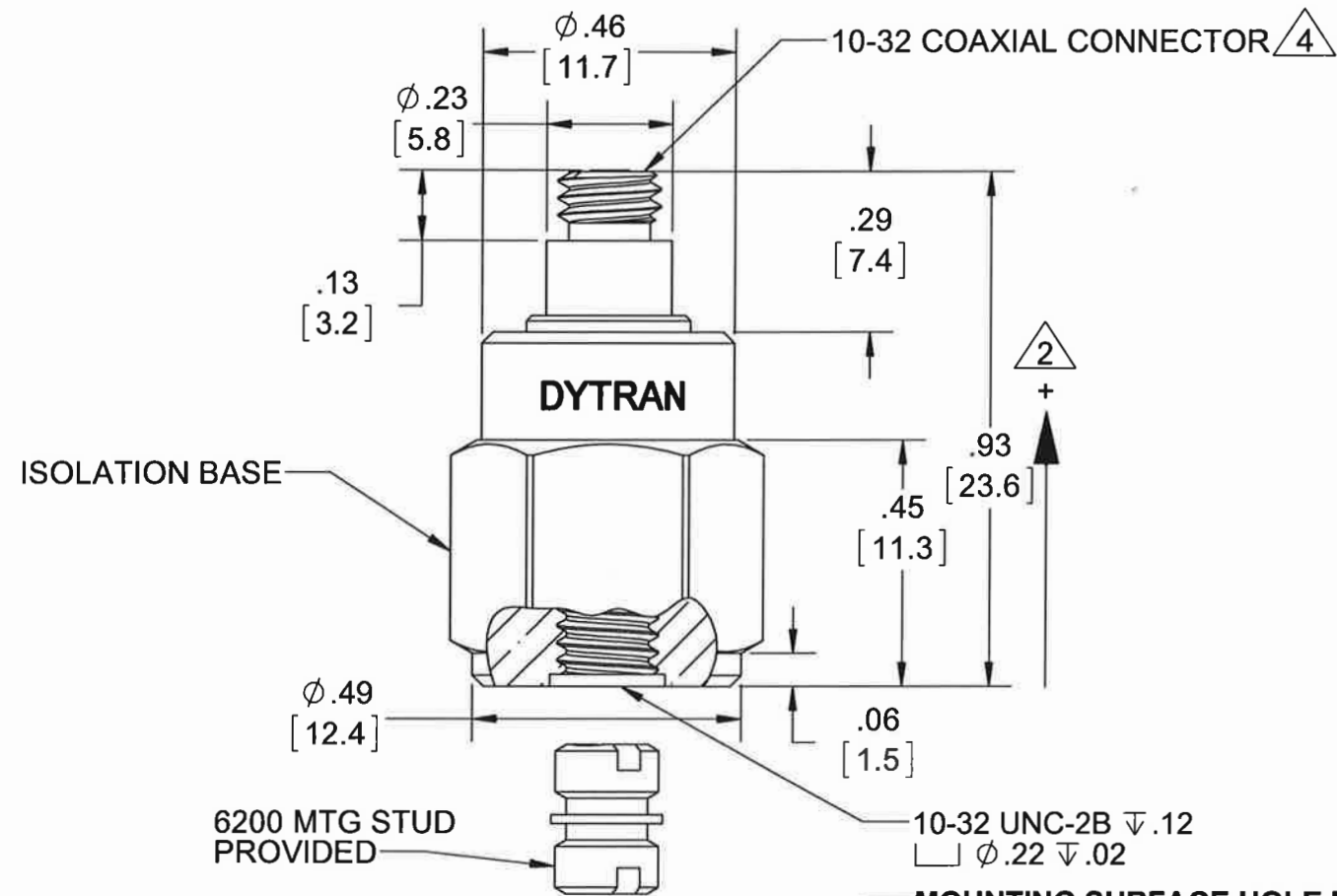
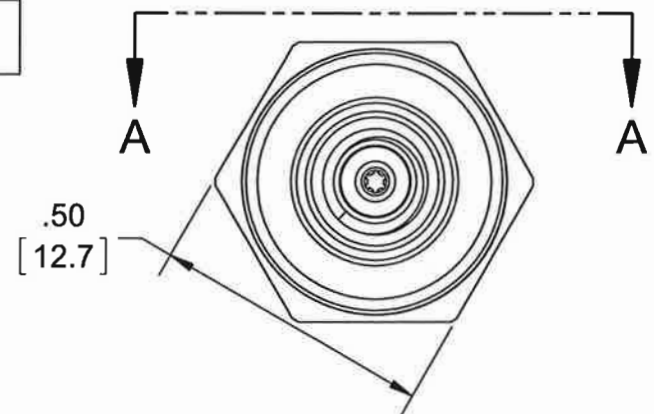

VIEW A-A
ROTATED 180°CW

6200 MTG STUD PROVIDED

10-32 UNC-2B ∇ .12
 \square ϕ .22 ∇ .02

MOUNTING SURFACE HOLE PREPARATION:
 SELECT SURFACE FLAT TO .001 TIR
 TAP 10-32 UNF-2B X .200 MIN THD DEPTH

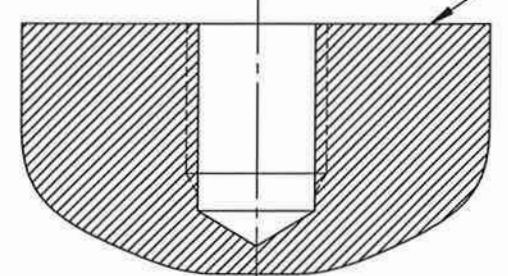

4 MATES WITH DYTRAN 6010AXX OR 6011AXX CABLE (XX=LENGTH IS FEET)

3. WEIGHT: 10 GRAMS (APPROX)

2 ARROW INDICATES ACCELERATION DIRECTION FOR POSITIVE OUTPUT.

1. MATERIAL: TITANIUM ALLOY

NOTES: UNLESS OTHERWISE SPECIFIED

UNLESS OTHERWISE SPECIFIED:
 INTERPRET DIM & TOL PER ASME Y14.5M - 1994.
 REMOVE BURRS.
 COUNTERSINK INTERNAL THDS 90° TO MAJOR DIA.
 CHAM EXT THDS 45° TO MINOR DIA.
 THD LENGTHS AND DEPTHS ARE FOR MIN FULL THDS.
 DIMENSIONS APPLY AFTER FINISHING.

ALL MACHINED SURFACES.
 TOTAL RUNOUT WITHIN .005.
 BREAK SHARP EDGES .005 TO .010.
 MACHINED FILLET RADII .005 TO .015.
 WELDING SYMBOLS PER AWS A2.4.
 ABBREVIATIONS PER MIL-STD-12.

APPROVALS		DATE
DRAWN	RA	10/29/14
DESIGN	RT	08/28/14
CHK	EM	12/12/14
APP	DV	12/17/14

DO NOT SCALE DRAWING

DYTRAN INSTRUMENTS, INC. Chatsworth, CA

MASTER ONLY IF IN RED

TITLE: **OUTLINE/INSTALLATION, MODEL 3056DX**

SIZE B	CAGE CODE 2W033	DWG NO 127-3056D	REV B
---------------	------------------------	-------------------------	--------------

SCALE: 3:1 PART NO: SHEET 1 OF 1

Model Number 3056D5	PERFORMANCE SPECIFICATIONS	DOC NO PS3056D5
IEPE ACCELEROMETER		REV B, ECN 11394, 10/31/14



- HERMETICALLY SEALED
- BASE ISOLATED

PHYSICAL

Weight
Connector
Mounting Provision
Material, Housing/Connector
Sensing Element
Element Style

ENGLISH		SI	
0.35	oz	10	grams
10-32	Type	10-32	
10-32 X .150 ↓	Tapped Hole	10-32 X .150 ↓	
Titanium		Titanium	
Ceramic		Ceramic	
Planar Shear		Planar Shear	

PERFORMANCE

Sensitivity, ±5% [1]
Range for ± 5 Volts Output
Frequency Response, ±10%
Resonant Frequency
Broad Band Resolution
Linearity [2]
Maximum Transverse Sensitivity
Strain Sensitivity @ 250µε

50	mV/G	5.1	mV/m/s ²
100	G peak	981	m/s ²
1 to 10,000	Hz	1 to 10,000	Hz
> 32	kHz	> 32	kHz
0.0010	G rms	0.0098	m/s ² rms
±1	% F.S.	±1	% F.S.
5	%	5	%
0.001	G/µε	0.01	m/s ² /µε

ENVIRONMENTAL

Maximum Vibration
Maximum Shock
Temperature Range
Seal

500	G peak	4905	m/s ² peak
3000	G peak	29430	m/s ² peak
-60 to 250	°F	-51 to 121	°C
HERMETIC		HERMETIC	

ELECTRICAL

Supply Current Range [3]
Compliance Voltage Range
Output Impedence, Typ
Bias Voltage
Discharge Time Constant
Electrical Isolation

2 to 20	mA	2 to 20	mA
+18 to +30	Volts	+18 to +30	Volts
100	Ω	100	Ω
+9 to +13	VDC	+9 to +13	VDC
.5 to 1.5	Sec	.5 to 1.5	Sec
10	GΩ,min	10	GΩ,min

This family also includes:

Model	Sensitivity (mV/g)	Frequency Response (Hz)	Time Constant (Sec)	Operating Temp (°F)
3056D1	10	1 to 10000	0.5 to 1.5	-60 to +250
3056D2	100	1 to 10000	0.5 to 1.5	-60 to +250
3056D3	500	1 to 10000	0.5 to 1.5	-60 to +225
3056D4	20	1 to 10000	0.5 to 1.5	-60 to +250
3056D6	200	1 to 10000	0.5 to 1.5	-60 to +225
3056D7	5	1 to 10000	0.5 to 1.5	-60 to +250

Refer to the performance specifications of the products in this family for detailed description

Supplied Accessories:

- 1) Accredited calibration certificate (ISO 17025)

Notes:

- [1] Measured at 100Hz, 1 Grms per ISA RP 37.2.
- [2] Measured using zero-based straight line method, % of F.S. or any lesser range.
- [3] Do not apply power to this system without current limiting, 20 mA MAX. To do so will destroy the IC charge amplifier.
- [4] In the interest of constant product improvement, we reserve the right to change specifications without notice.

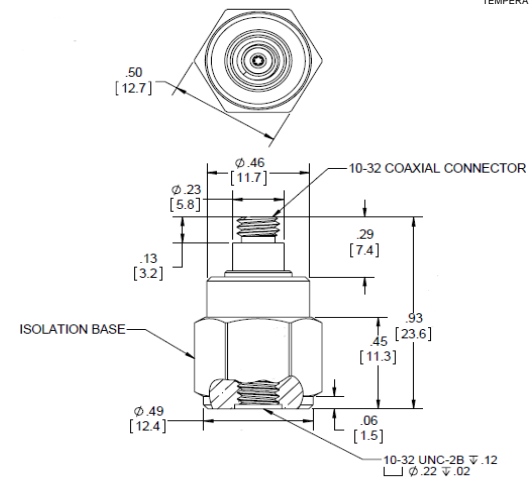
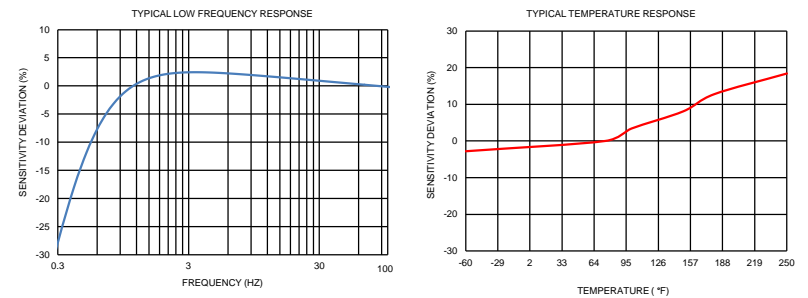

Units on the line drawing are in inches, units in brackets are in millimeters. Refer to 127-3056D for more information.



21592 Marilla Street, Chatsworth, California 91311 Phone: 818.700.7818 Fax: 818.700.7880 www.dytran.com
For permission to reprint this content, please contact info@dytran.com



Presented by: Absolute Gauge Technologies
sales@absolute-gauge.com; www.absolute-gauge.com,
Toronto: 416 754 3168, Montreal: 514 695 5147, Toll Free: 1 888 754 7008