

PROPRIETARY AND CONFIDENTIAL

THE INFORMATION CONTAINED IN THIS DRAWING IS THE SOLE PROPERTY OF DYTRAN INSTRUMENTS INC. ANY REPRODUCTION IN PART OR AS A WHOLE WITHOUT THE WRITTEN PERMISSION OF DYTRAN INSTRUMENTS INC. IS PROHIBITED

MODEL	REV	ECN	DATE	INPUT RANGE
7705A1	B	11048	09/04/14	±200g
7705A2	B	11048	09/04/14	±40g
7705A3	B	11048	09/04/14	±20g

REVISIONS					
REV.	ECN	DESCRIPTION	BY/DATE	CHK	APPR
A	10745	INITIAL RELEASE	JS 01/24/14	DV	AS
B	11048	SEE ECN	EM 06/12/14	MH	

D

D

C

C

B

B

A

A

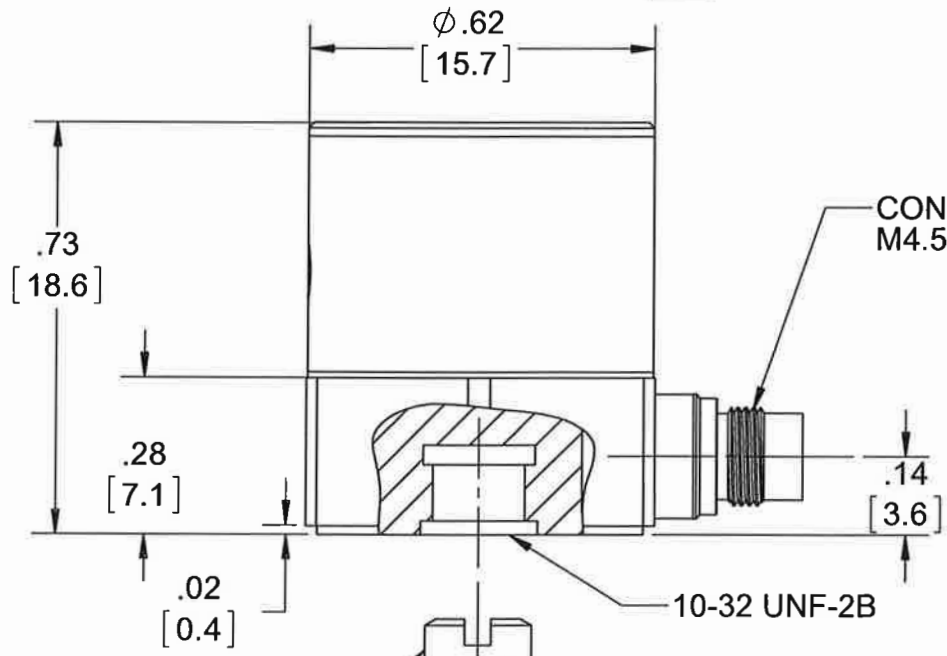
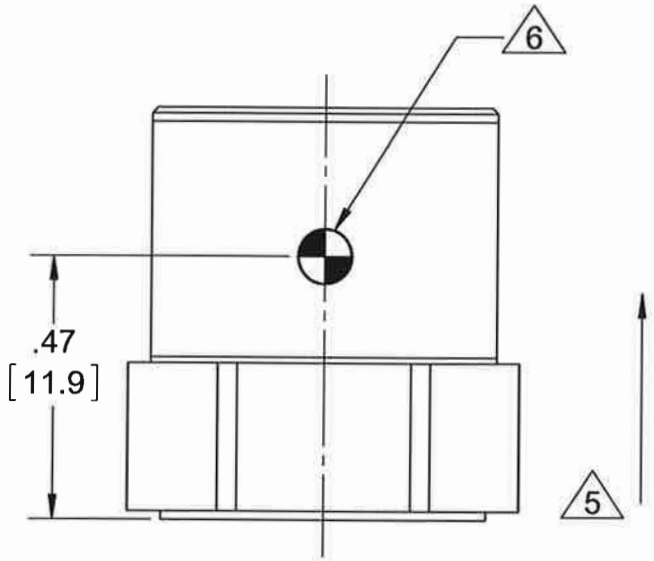
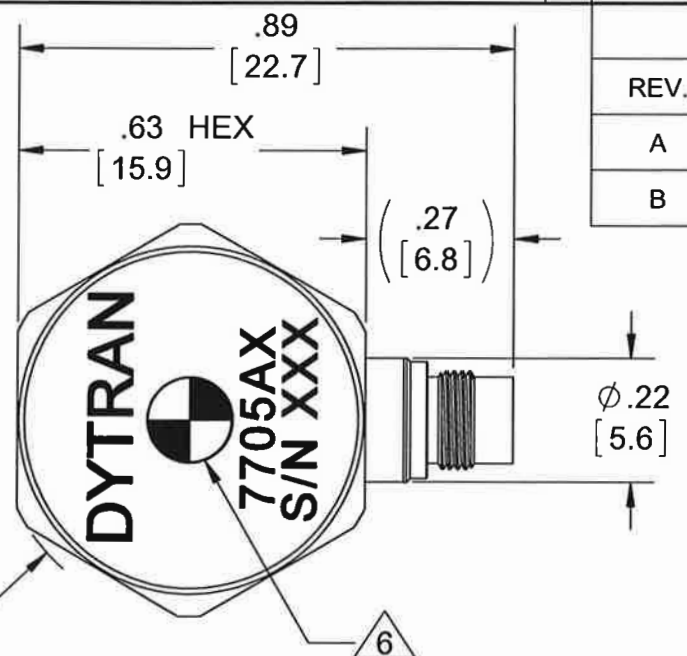

CONNECTOR, 4-PIN M4.5 X 0.35

PIN 4 - GROUND

PIN 1 - SIG OUTPUT

PIN 3 - N/C

PIN 2 - POWER

RECOMMENDED MOUNTING PREPARATION:
 PREPARE FLAT MOUNTING SURFACE, Ø.65 [16.5] MIN, FLAT TO .001 TIR.
 TAP 10-32 UNF-2B ∇.200 [5.1] MIN. TORQUE TO 10-12 Lb-in.

- 6 MARKING DENOTES LOCATION OF SENSING ELEMENT'S CENTER OF MASS
- 5 ARROW INDICATES DIRECTION OF ACCELERATION FOR POSITIVE OUTPUT.
- 4 MOUNTING STUD, 10-32, MODEL 6200, SUPPLIED.

- 3 MATES WITH MODEL 6776AXX 4 PIN TO (2) BNC OR 6895AXX 4 PIN TO CUT OFF CABLE (XX = LENGTH IN FEET).
 - 2. HOUSING/CONNECTOR MATERIAL: TITANIUM ALLOY.
 - 1. WEIGHT: 20 GRAMS, MAX.
- NOTES: UNLESS OTHERWISE SPECIFIED

UNLESS OTHERWISE SPECIFIED: INTERPRET DIM & TOL PER ASME Y14.5M - 1994. REMOVE BURRS. COUNTERSINK INTERNAL THDS 90° TO MAJOR DIA. CHAM EXT THDS 45° TO MINOR DIA. THD LENGTHS AND DEPTHS ARE FOR MIN FULL THDS. DIMENSIONS APPLY AFTER FINISHING.		UNLESS OTHERWISE SPECIFIED: DIMENSIONS ARE IN INCHES. DIMENSIONS IN BRACKETS [] ARE IN MILLIMETERS TOLERANCES ARE:	
DECIMALS .XX ±.03 .XXX ±.010	METRIC .X ±.08 .XX ±0.25	ANGLES ±1°	
APPROVALS		DATE	
ORIG	LN	08/29/13	
CHK	DV	01/28/14	
APP	AS	01/28/14	
DO NOT SCALE DRAWING		THIRD ANGLE PROJECTION	

DYTRAN INSTRUMENTS, INC. MASTER ONLY IF IN RED

TITLE: **OUTLINE/INSTALLATION DRAWING, 7705A SERIES**

SIZE B	CAGE CODE 2W033	DWG NO 127-7705A	REV B
-----------	--------------------	---------------------	----------

SCALE: 4:1 SHEET 1 OF 1

Model Number 7705A3	PERFORMANCE SPECIFICATIONS	DOC NO PS7705A3
DUAL ELEMENT ACCELEROMETER		
		REV C, ECN 11319, 09/22/14



- **DUAL ELEMENT TECHNOLOGY**
- **EXTENDED LOW FREQUENCY RESPONSE (0 Hz to 10kHz)**
- **HERMETICALLY SEALED**

New type of accelerometer from Dytran Instruments Inc. combines the DC output of variable capacitance element with excellent high frequency response of piezoelectric sensor. Both outputs are electrically summed up and seamlessly superimposed on each other to provide the broadest frequency response from a single output pin.

PHYSICAL
Weight, Max.
Mounting
Connector
Housing

ENGLISH		SI	
Weight, Max.	0.51 oz	14.5 grams	
Mounting	10-32 Tapped Hole	10-32 Tapped Hole	
Connector	4-pin, M4.5X0.35	4-pin, M4.5X0.35	
Housing	Titanium	Titanium	

PERFORMANCE

Sensitivity, ±10% [1]
Acceleration Range
Frequency Response, ±10%
Resonance Frequency
Linearity [2]
Transverse Sensitivity
Output Noise, Broadband, Max.
Phase shift mismatch, Max
Absolute phase shift, Max [3]
Base Strain
Bias Offset

Sensitivity, ±10% [1]	100 mV/g	10.2 mV/m/s ²	
Acceleration Range	±20 g's peak	±196 m/s ² peak	
Frequency Response, ±10%	0 to 10,000 Hz	0 to 10,000 Hz	
Resonance Frequency	>38 kHz	>38 kHz	
Linearity [2]	1 % F.S.	1 % F.S.	
Transverse Sensitivity	<3 %	<3 %	
Output Noise, Broadband, Max.	0.001 Grms	0.0098 m/s ² rms	
Phase shift mismatch, Max	+/-2 degrees	+/-2 degrees	
Absolute phase shift, Max [3]	+/-5 degrees	+/-5 degrees	
Base Strain	0.0004 g/με	0.0039 m/s ² /με	
Bias Offset	0.2 g's	1.96 m/s ²	

ENVIRONMENTAL

Maximum Mechanical Shock
Bias Temperature Shift, Max [3]
Bias Calibration Error
Operating Temperature
Thermal Coefficient
Seal

Maximum Mechanical Shock	5,000 Gpeak	49,050 m/s ²	
Bias Temperature Shift, Max [3]	56 (ppm of span)/°F	101 (ppm of span)/°C	
Bias Calibration Error	1.5 % of span	1.5 % of span	
Operating Temperature	-60 to +250 °F	-51 to 121 °C	
Thermal Coefficient	0.06 %/°F	0.12 %/°C	
Seal	Hermetic	Hermetic	

POWER

Compliance Voltage
Current Range
Output Bias Voltage, Typical
Output Impedance, Nom.
Power Supply Rejection Ratio

Compliance Voltage	+5 to +28 VDC	+5 to +28 VDC	
Current Range	5 to 10 mA DC	5 to 10 mA DC	
Output Bias Voltage, Typical	2.5 VDC	2.5 VDC	
Output Impedance, Nom.	1 Ω	1 Ω	
Power Supply Rejection Ratio	>65 dB	>65 dB	

This family also includes:

Model	Sensitivity (mV/g)	Range (Gpeak)	Maximum Shock (Gpeak)	Noise Broadband (grms)
7705A1	10	±200	5,000	0.004
7705A2	50	±40	5,000	0.002

Refer to the performance specifications of the products in this family for detailed description

Supplied Accessories:

- 1) Accredited calibration certificate (ISO 17025)
- 2) Model 6200 mounting stud (10-32 to 10-32) Qty. 1
- 3) Model 6693 mounting stud (10-32 to M5) Qty. 1

Notes:

- [1] Measured at 100Hz, 1 Grms per ISA RP 37.2.
- [2] Measure using zero-based straight line method, % of F.S. or any lesser range.
- [3] 0 to 1000Hz
- [4] In the interest of constant product improvement, we reserve the right to change specifications without notice.

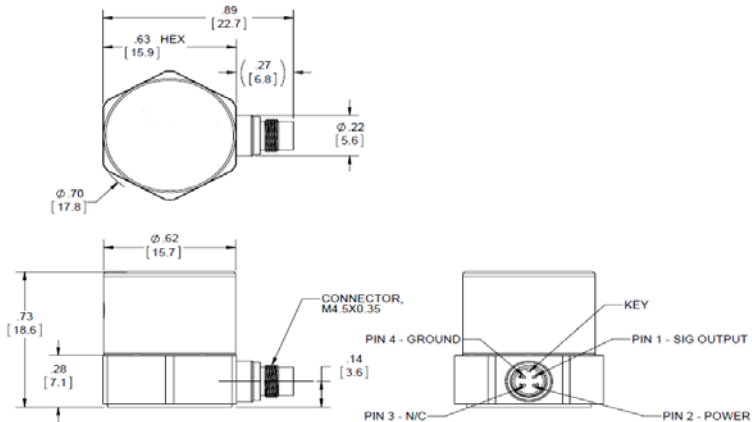
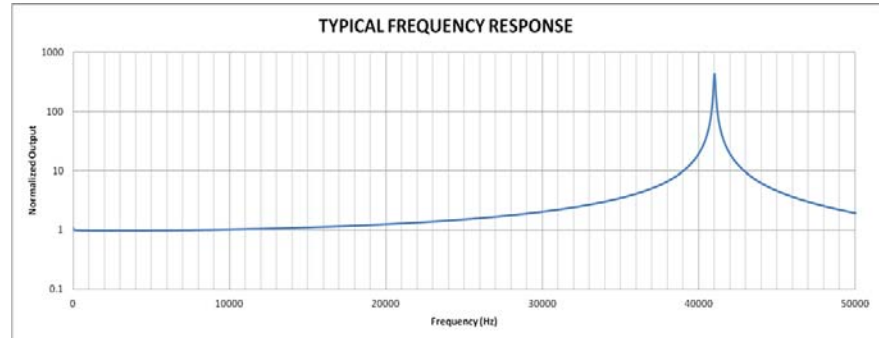

Units on the line drawing are in inches, units in brackets are in millimeters. Refer to 127-7705A for more information.



21592 Marilla Street, Chatsworth, California 91311 Phone: 818.700.7818 Fax: 818.700.7880 www.dytran.com
For permission to reprint this content, please contact info@dytran.com



Presented by: Absolute Gauge Technologies
sales@absolute-gauge.com; www.absolute-gauge.com,
Toronto: 416 754 3168, Montreal: 514 695 5147, Toll Free: 1 888 754 7008