

## Single-Turn Conductive Plastic Potentiometers

### PL240 Series



#### Special features

- very small dimensions
- $1 \times 10^6$  movements
- linearity  $\pm 2\%$
- excellent resolution – better than  $0.1^\circ$

Low-cost potentiometer with a conductive plastic resistance element for control electronics and measuring applications.

Careful selection of materials and high-quality components ensure a constant and accurate angle measurement throughout the entire service life of the sensor.

Special designs with other angular ranges, and shaft dimensions are available on request.

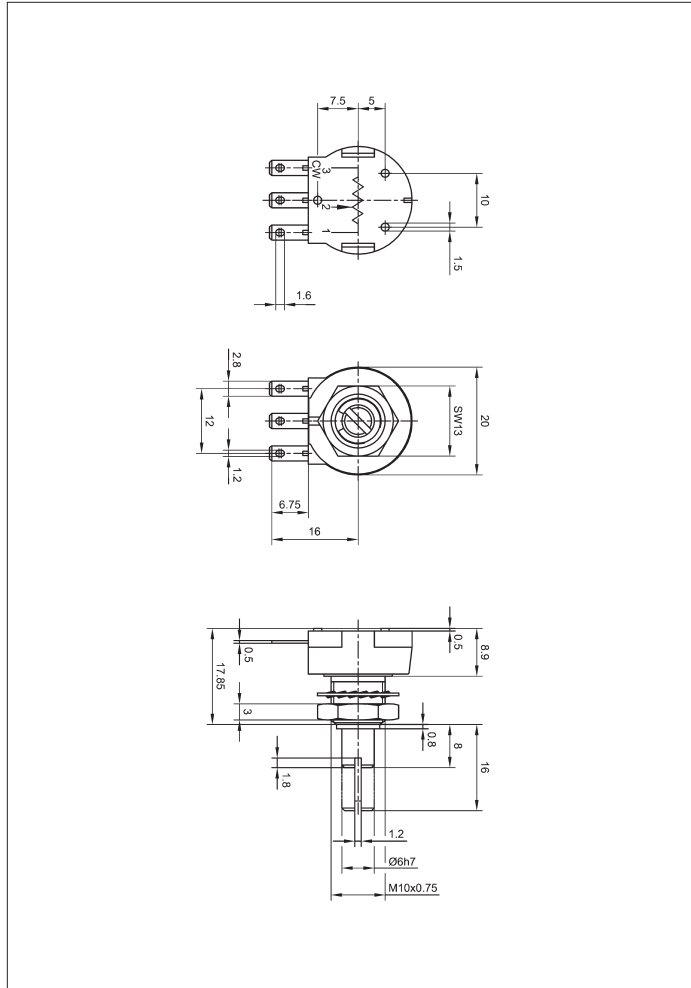

Description	
Size	housing diameter 20 mm
Housing	high-quality, temperature-consistent plastic
Shaft	brass, nickel plated
Bearings	sleeve bearings
Resistance element	conductive plastic
Wiper assembly	precious metal
Electrical connections	tin plated

Mechanical Data		
Dimensions	see drawing	
Mounting	nut M10 x 0.75 and serrated washer 3/8"	
Mechanical travel	300	°
Permitted shaft loading (axial and radial) static or dynamic force	1	N
Torque	≤ 1	Ncm
Permitted max. torque for mech. stops	100	Ncm
Maximum operational speed	120	RPM
Weight	14	g

Electrical Data		
Actual electrical travel	270 ±3	°
Available resistance values	1; 5; 10	Ω
Resistance tolerance	±20	%
Repeatability	0.04 (=0.1°)	%
Effective temperature coefficient of the output-to-applied voltage ratio	50 (typical)	ppm/K
Independent linearity	±2	%
Max. permissible applied voltage	18	V
Recommended operating wiper current	≤ 1	μA
Max. wiper current in case of malfunction	10	mA
Insulation resistance (500 VDC, 1 bar, 2 s)	≥ 10,000	MΩ
Dielectric strength AC, 50 Hz, 1 min, 1 bar)	1,500	V

Environmental Data		
Temperature range	-25...+125	°C
Vibration	30...2000 A <sub>max</sub> = 0.75 a <sub>max</sub> = 10	Hz mm g
Life	1 x 10 <sup>6</sup>	movements
Shock (DIN IEC 68 T2-27)	50 7	g ms
Protection class (DIN 40050)	IP 50	

Order designations					
Type	Art. no.	R in kΩ	Length of shaft in mm		
PL240 1K0 4A160 MB	79950	1	16		
PL240 5K0 4A160 MB	79951	5	16		
PL240 10K0 4A160 MB	79952	10	16		

**Order designations / Abbreviations**

4A: connecting pin, radial  
 MB: bushing M10 x 0.75 axis Ø 6 mm with slot

**Included in delivery**

1 nut M10 x 0.75  
 1 serrated washer 3/8"

**Recommended accessories**

Fork coupling Z 104 G6, Art. no. 005690;  
 Fork coupling Z 105 G6 (backlash-free), Art. no. 005691, MAP process-control indicators and display. MUP signal conditioner for standardized output signals.

**Important**

All values given for this series – including linearity, lifetime, micro-linearity, resistance to external disturbances and temperature coefficient in voltage dividing mode – are quoted for the device operating with the wiper voltage driving an operational amplifier working as a voltage follower where virtually no load is applied to the wiper (I<sub>e</sub> ≤ 1 μA).