



Model		THP550
Type		Horizontal multi-joint
No. of controlled axes		4
Arm length		550 mm (300 mm+250 mm)
Working envelope	Axis 1	±120°
	Axis 2	±145°
	Axis 3 (Z-axis)	150 mm (optional: 300 mm)
	Axis 4 (Z-axis rotation)	±360°
Maximum speed	Axis 1	375°/s
	Axis 2	600°/s
	Axis 3 (Z-axis)	2000 mm/s
	Axis 4 (Z-axis rotation)	2000°/s
Composite		6.21 m/s
Standard cycle time (with 2kg load)		0.29 s *2
Maximum payload mass		2 kg (rated: 1kg)
Allowable moment of inertia		0.01 kgm ² *3
Positioning X-Y		±0.015 mm *4
repeatability	Axis 3 (Z-axis)	±0.01 mm *4
	Axis 4 (Z-axis rotation)	±0.02° *4
Hand wiring		8 inputs / 8 outputs
Hand piping		4 pcs. (φ4)
Position detection		Absolute
Robot controller cable		5 m (optional: max. 25 m)
Mass		26 kg

■ For *2, *3 and *4, see page 5.



Model		THP700
Type		Horizontal multi-joint
No. of controlled axes		4
Arm length		700 mm (350 mm+350 mm)
Working envelope	Axis 1	±120°
	Axis 2	±145°
	Axis 3 (Z-axis)	150 mm (optional: 300 mm)
	Axis 4 (Z-axis rotation)	±360°
Maximum speed	Axis 1	340°/s
	Axis 2	600°/s
	Axis 3 (Z-axis)	2050 mm/s
	Axis 4 (Z-axis rotation)	1800°/s
Composite		7.8 m/s
Standard cycle time (with 2kg load)		0.345 s *2
Maximum payload mass		10 kg
Allowable moment of inertia		0.01 kgm ² *3
Positioning X-Y		±0.03 mm *4
repeatability	Axis 3 (Z-axis)	±0.02 mm *4
	Axis 4 (Z-axis rotation)	±0.02° *4
Hand wiring		8 inputs / 8 outputs
Hand piping		4 pcs. (φ6)
Position detection		Absolute
Robot controller cable		5 m (optional: max. 25 m)
Mass		57 kg

■ For *2, *3 and *4, see page 5.

External view

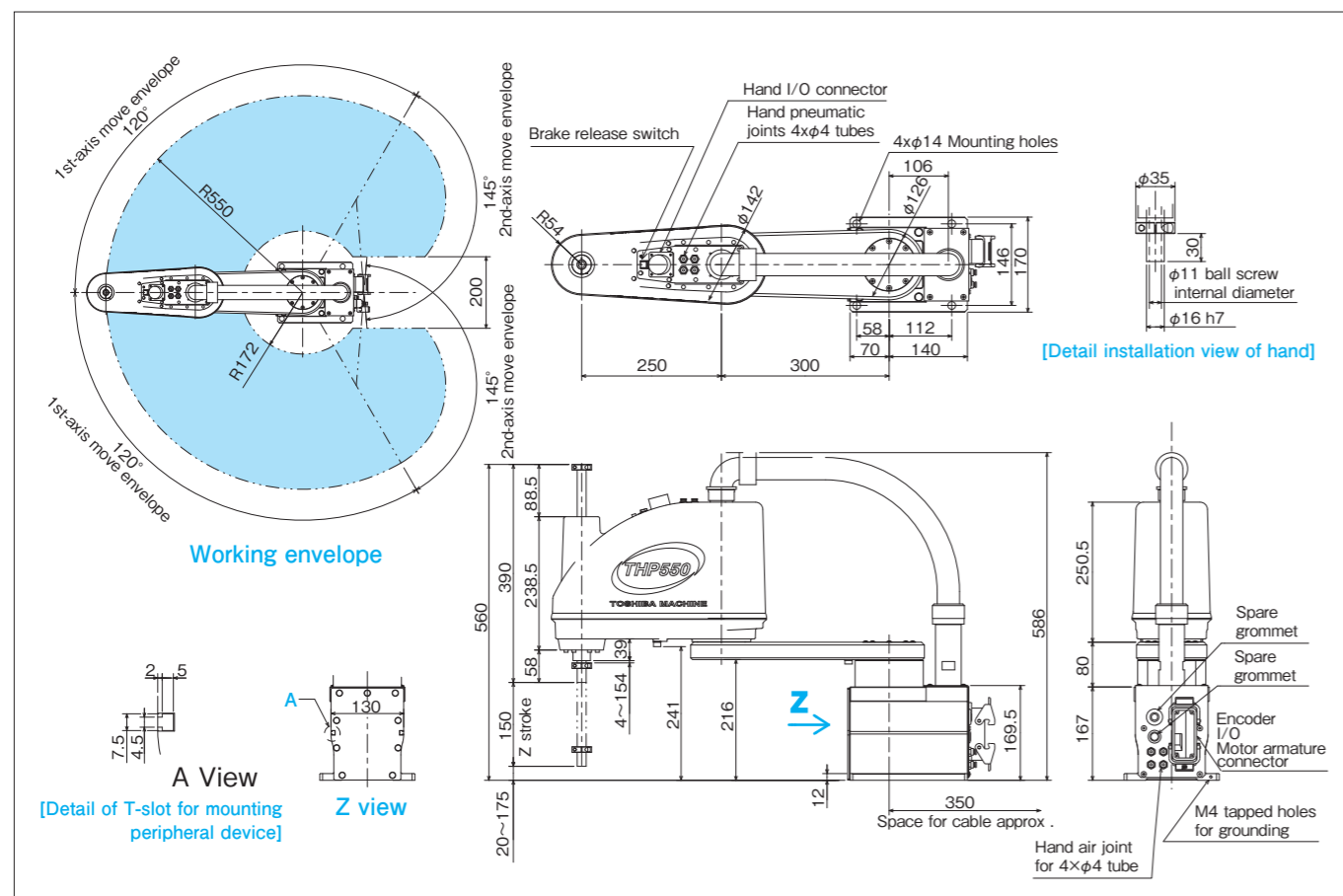

External view

