

MV-CU020-90GM/GC

2 MP 1/1.7" CMOS GigE Area Scan Camera



GEN*<i>i>*CAM

GIG*E*
VISION

Introduction

MV-CU020-90GM/GC camera adopts GMAX4002 CMOS sensor to provide high-quality images. It uses GigE interface to transmit non-compressed images in real time, and its max. frame rate can reach 49 fps in full resolution.

Key Feature

- Adopts low consumption design with stable performance.
- Supports auto or manual adjustment of gain, exposure time, and manual adjustment of LUT, Gamma correction, etc.
- Supports customized ROI and supports horizontal and vertical reverse image output.
- Adopts compact design to meet small spatial requirements.
- Compatible with GigE Vision V2.0 Protocol, GenCam Standard, and third-party software based on the protocol and standard.

Available Model

- Mono camera: MV-CU020-90GM
- Color camera: MV-CU020-90GC

Applicable Industry

Electronics and semiconductor, factory automation, logistics and code reading, bottle detection, medicine package, etc.

Sensor Quantum Efficiency

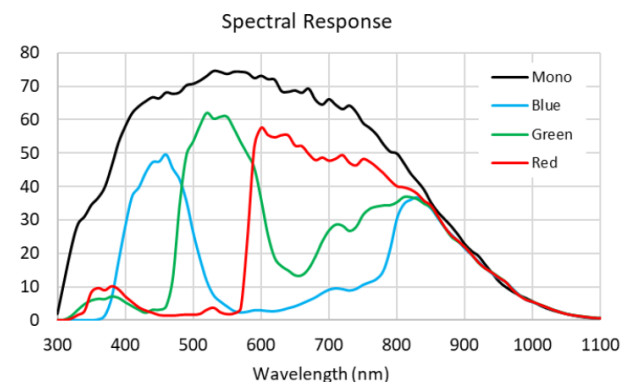

Dimension

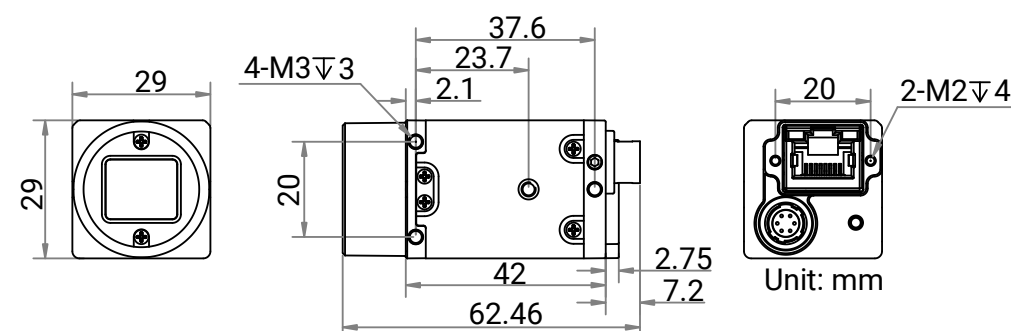

Specification

Model	MV-CU020-90GM	MV-CU020-90GC
Performance		
Sensor type	CMOS, global shutter	
Sensor model	GMAX4002	
Pixel size	4 μm × 4 μm	
Sensor size	1/1.7"	
Resolution	2048 × 1200	
Max. frame rate	49 fps@ 2048 × 1200 Mono 8	49 fps@ 2048 × 1200 Bayer GB 8
Dynamic range	66.9 dB	
SNR	40.8 dB	
Gain	0 dB to 11.1 dB	
Exposure time	4 μs to 10 sec	
Exposure mode	Off/Once/Continuous exposure mode	
Mono/color	Mono	Color
Pixel format	Mono 8/10/10Packed/12/12Packed	Bayer GB 8/10/10Packed/12/12Packed
Binning	Supports 1 × 1, 2 × 2, 4 × 4	
Decimation	Supports 1 × 1, 2 × 2, 4 × 4	
Reverse image	Supports horizontal and vertical reverse image output	
Electrical features		
Data interface	Gigabit Ethernet, compatible with Fast Ethernet	
Digital I/O	6-pin P7 connector provides power and I/O, including opto-isolated input × 1 (Line 0), opto-isolated output × 1 (Line 1), bi-directional non-isolated I/O × 1 (Line 2).	
Power supply	9 VDC to 24 VDC, PoE is optional	
Power consumption	Typ. 1.9 W @12 VDC	Typ. 2 W @12 VDC
Mechanical		
Lens mount	C-mount	
Dimension	29 mm × 29 mm × 42 mm (1.1" × 1.1" × 1.7")	
Weight	Approx. 100 g (0.2 lb.)	
Ingress protection	IP30 (under proper lens installation and wiring)	
Temperature	Working temperature: 0 °C to 50 °C (32 °F to 122 °F) Storage temperature: -30 °C to 70 °C (-22 °F to 158 °F)	
Humidity	20% to 95% RH, non-condensing	
General		
Client software	MVS or third-party software meeting with GigE Vision Protocol	
Operating system	32/64-bit Windows XP/7/10, 64-bit Windows 11, 32/64-bit Linux and 64-bit MacOS	
Compatibility	GigE Vision V2.0, GenICam	
Certification	CE, RoHS, KC	