

MV-CS200-10GM/GC-ADV

20 MP 1" CMOS GigE Area Scan Camera



GEN*i*CAM

GigE VISION

Introduction

With GigE interface, MV-CS200-10GM/GC-ADV camera adopts Sony® IMX183 sensor to provide high-quality images and transmit images in real time, and its max. frame rate can reach 5.9 fps in full resolution.

Key Feature

- Supports auto or manual adjustment of gain, exposure time, white balance, LUT, Gamma correction, etc.
- Supports multiple ISP functions like CCM to provide high-quality images.
- Compact design with mounting holes on panels for flexible mounting from 4 sides.
- Adopts GigE interface and max. transmission distance of 100 meters without relay.
- Compatible with GigE Vision V2.0 Protocol, GenICam Standard, and third-party software based on the protocol and standard.

Dimension

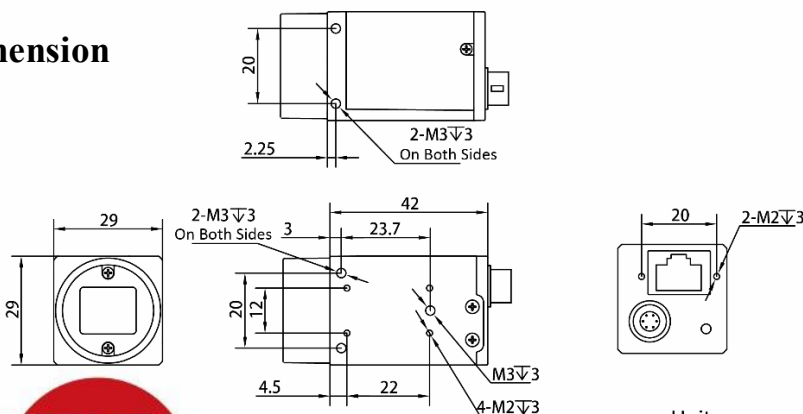

Available Model

- Mono camera: MV-CS200-10GM-ADV
- Color camera: MV-CS200-10GC-ADV

Applicable Industry

SMT/ PCB AOI, consumer electronics, electrical semiconductor, etc.

Sensor Quantum Efficiency

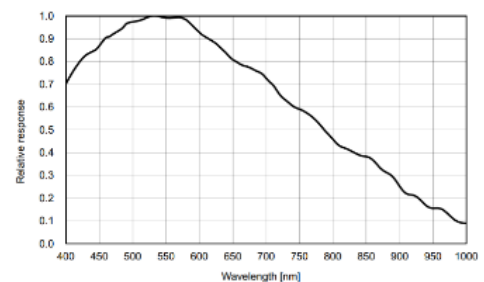

MV-CS200-10GM-ADV

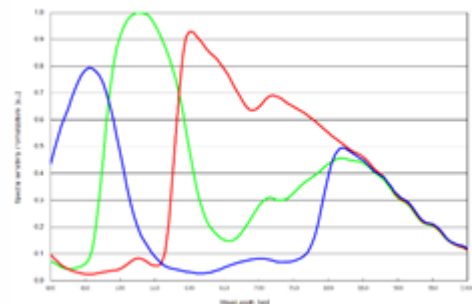

MV-CS200-10GC-ADV



Specification

Model	MV-CS200-10GM-ADV	MV-CS200-10GC-ADV
Camera		
Sensor type	CMOS, rolling shutter	
Sensor model	Sony® IMX183	
Pixel size	2.4 μm × 2.4 μm	
Sensor size	1"	
Resolution	5472 × 3648	
Max. frame rate	5.9 fps @5472 × 3648	
Dynamic range	65.5 dB	
SNR	41.5 dB	
Gain	0 dB to 24 dB	
Exposure time	46 μs to 2.5 sec	
Exposure mode	Off/Once/Continuous exposure auto, supports Timed and Trigger Width exposure mode, and Rolling and Global Reset sensor shutter mode	
Mono/color	Mono	Color
Pixel format	Mono 8/10/10p/12/12p	Mono 8/10/12, Bayer GB 8/10/10p/12/12p, YUV422Packed, YUV422_YUYV_Packed, RGB 8, BGR 8
Binning	Supports 1 × 1, 2 × 2, 4 × 4	
Decimation	Supports 1 × 1, 2 × 2	
Reverse image	Supports horizontal and vertical reverse image output	
Electrical features		
Data interface	Gigabit Ethernet, compatible with Fast Ethernet	
Digital I/O	6-pin Hirose connector provides power and I/O, including opto-isolated input × 1 (Line 0), opto-isolated output × 1 (Line 1), bi-directional non-isolated I/O × 1 (Line 2).	
Power supply	9 VDC to 24 VDC, supports PoE	
Power consumption	Typ. 2.4 W@12 VDC	Typ. 2.5 W@12 VDC
Mechanical		
Lens mount	C-Mount	
Dimension	29 mm × 29 mm × 42 mm (1.1" × 1.1" × 1.2")	
Weight	Approx. 100 g (0.22 lb.)	
Ingress protection	IP40 (under proper lens installation and wiring)	
Temperature	Working temperature: -30 °C to 60 °C (-22 °F to 140 °F) Storage temperature: -30 °C to 70 °C (-22 °F to 158 °F)	
Humidity	20% to 95% RH, non-condensing	
General		
Client software	MVS or third-party software meeting with GigE Vision Protocol	
Operating system	32/64-bit Windows XP/7/10, 32/64-bit Linux and 64-bit MacOS	
Compatibility	GigE Vision V2.0, GenICam	
Certification	CE, RoHS, KC	

HIKROBOT

Hangzhou Hikrobot Co., Ltd.
 en.hikrobotics.com

© Hangzhou Hikrobot Co., Ltd. All Rights Reserved.

Hangzhou Hikrobot does not tolerate any infringement. Any organization or individual may not imitate or reproduce in whole or in part of the content. The data herein is based on Hikrobot's internal evaluation. Actual data may vary depending on specific configuration and operating condition. The information herein is subject to change without notice. All the content has been checked conscientiously. Nevertheless, Hikrobot shall not be liable to damages resulting from errors, inconsistencies or omissions.