

NetScanner™ System

9022

FEATURES

- Low Pass Anti-aliasing Filter per Channel
- Up to $\pm 0.05\%$ System Accuracy
- EU Throughput Rates of 100 Hz
- 10 BaseT Ethernet Interface, TCP & UDP Protocol
- Pressure Ranges from 5 psi (34 kPa) to 10,000 psi (69 MPa)
- Supports 3rd Party Transducers and Voltage Measurements
- Triple Scan List Capability
- Rugged Splashproof Enclosure
- Hardware and Software Triggered Data Acquisition

APPLICATIONS

- Turbomachinery Test Stands
- Portable Test Systems
- Process Monitoring
- Hydraulic/Pneumatic Systems



The Model 9022 All-Media Intelligent Pressure Scanner is a completely self-contained pressure acquisition module for multiple measurements of liquids and high pressure dry non-corrosive gases. The rugged compact scanner is designed to interface up to 12 Series 9400 All-Media Pressure Transducers or third-party pressure transducers. The scanner incorporates a low pass 30 Hz anti-aliasing filter for each channel. In addition, 5 VDC signals can be measured on any unused input channel. The 9022 also provides a precision +5 or +10 VDC excitation source to power external transducers.

When used with 9400 transducers, the microprocessor corrects for pressure transducer zero, span, nonlinearity errors using data stored in the 9400's integral EEPROM. It also performs digital temperature compensation of the 9400s to reduce thermal errors by a factor of ten or more over conventional sensor compensation. The microprocessor also facilitates off-line rezero and span calibrations to maintain optimum sensor accuracy. This turnkey approach to all-media pressure measurements provides system static accuracy of up to $\pm 0.05\%$ FS.

The 9022 can sample using up to three concurrent scan lists at continuous rates of up to 100 measurements per channel per second in engineering units. Pressure data in engineering units is output through an Ethernet 10 BaseT interface using industry standard TCP or UDP protocol. The scanner is supplied with comprehensive Visual Basic-based software called NUSS for PC compatible computers. Firmware upgrades are made available at no charge via PSI's website and can be downloaded to the scanner over the Ethernet interface using NUSS.

The Model 9022 All-Media Intelligent Pressure Scanner is one component of the NetScanner™ System. Multiple NetScanner components measuring a variety of parameters and sharing the same command set can be networked to form a distributed intelligent data acquisition system.

After 1 hour warmup @ 25°C with atmospheric reference pressure unless otherwise stated, FS = Full Scale

Parameter	9022	Units	Comments
PRESSURE CHARACTERISTICS			
Number of Measurements Supported	12	channels	pressure transducers or voltage inputs
STATIC ACCURACY, RESOLUTION & THERMAL PERFORMANCE			
Measurement Resolution	±0.003	% FS	
Anti-Aliasing Filter	30	Hz	cutoff frequency 4 pole Bessel filter on pressure and temperature signals
Voltage Measurement Accuracy ¹	±0.025 ±0.025 ±0.05 ±0.05	% FS % FS % FS % FS	0 to 4500 mV 0 to 250 mV 0 to 100 mV 0 to 50 mV
Thermal Error	±.001	%FS/°C	when operating outside the calibrated temp range using FS voltage ranges ≤ 250 mV
DATA SCAN & TRANSFER RATES			
Measurement Scan Rate	100	meas/ch/ sec	
COMMUNICATION			
Ethernet	10Base T		half duplex
Protocol	TCP and UDP		static or dynamic IP assignment
POWER/SIGNAL REQUIREMENTS			
Input Voltage	18 to 36	VDC	unregulated supply
Input Current	330	mA	max ² @ 24VDC
Hardware Trigger Threshold	2.5	VDC	TTL compatible diff input, ±5 VDC common mode
TRANSDUCER EXCITATION VOLTAGE CHARACTERISTICS			
Excitation Voltage	5 or 10	VDC	user selectable, 10 VDC default
Excitation Accuracy	±0.07	%	@ 25°C
Temperature Coefficient	20	ppm/°C	
Long Term Stability	15	ppm	measured over 24 hours
Load Regulation	0.3	%	100mA max total load

Notes:

- For channels measuring voltage inputs, measurements made from -FS to 0 VDC are specified at twice the error specification for the related range.
- Worst case at maximum transducer load.

Parameter	9022	Units	Comments
ENVIRONMENTAL/PHYSICAL			
Calibrated Temp Range	0 to 50	°C	Consult factory for extended temps
Operating Temp Range	-30 to 70	°C	< 95% non-condensing humidity
Storage Temp	-30 to 80	°C	
Size	9.5 x 3.5 x 3.4 (24 x 9 x 8.7)	inches (cm)	L x W x H
Weight	4.3 (1.95)	lb (kg)	

Refer also to Series 9400 Digitally Compensated
All-Media Pressure Transducer datasheet for transducer specifications.

The 9022 integrates discrete pressure transducers with a miniature data acquisition system to provide a multichannel pressure scanner. The integration of the microprocessor with the pressure transducers provides several benefits in addition to the compact nature of the Intelligent Pressure Scanner. This pre-engineered approach to pressure acquisition offers guaranteed system accuracy, unlike individual pressure transducers where stated accuracy is met only if the many user-considerations are addressed, especially with respect to temperature effects and zero drift. Model 9022 All-Media Intelligent Pressure Scanners, when used in conjunction with the Series 9400 digitally compensated pressure transducers, output pressure data in engineering units, digitally compensated for zero, span, nonlinearity, and temperature effects.

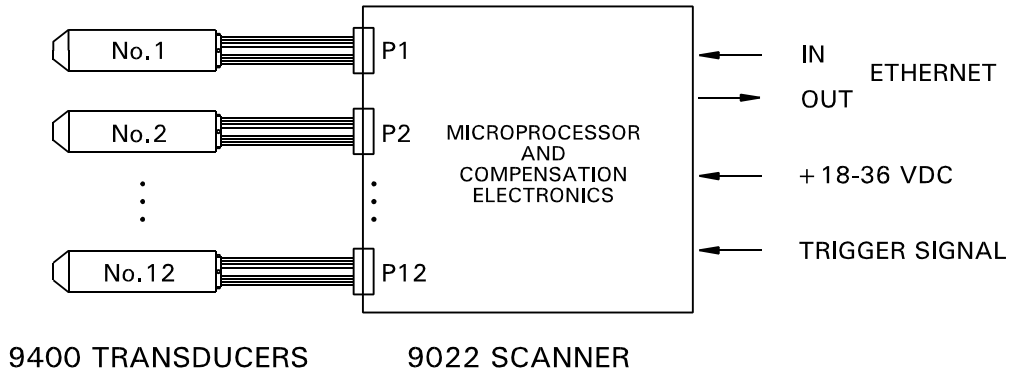

All-Media Intelligent Pressure Scanner Functional Diagram

Digital Sensor Temperature Compensation

Silicon piezoresistive pressure sensors are low cost, miniature pressure sensing elements ideal for packaging individually for each pressure port. However, like most sensors, they are affected by temperature. Since these effects are repeatable, sensor calibration over temperature and pressure can be used to characterize and correct these errors. Pressure Systems incorporates digital sensor temperature compensation technology in the Series 9400 pressure transducers.

Each digitally temperature compensated Series 9400 pressure transducer is packaged along with a nonvolatile memory device (EEPROM) and a temperature sensor in its own stainless steel housing. The transducers are factory-calibrated over the specified pressure and temperature spans. The resultant calibration data, along with the pressure range and serial number of the sensor, are stored in the integral EEPROM. The onboard microprocessor utilizes this information to compensate transducer outputs for offset, sensitivity, nonlinearity, and thermal effects before transferring pressure data to the host computer. Should a transducer be replaced, the microprocessor will recognize the new transducer upon power-up and extract the calibration information from the EEPROM.

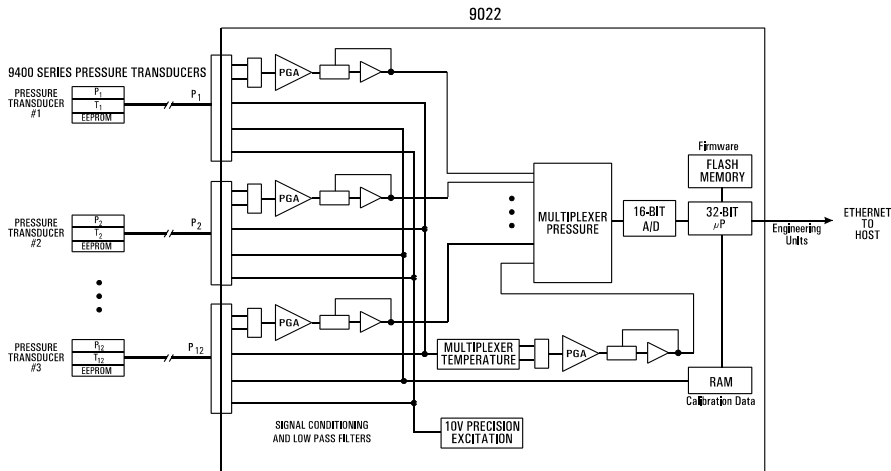

Series 9400 Pressure Transducer

The Series 9400 Pressure Transducers are designed for industrial pressure measurement applications where all-media compatibility, with good accuracy and stability are required. The Series 9400 is designed to integrate directly with PSI's 9022 All-Media Scanner. The transducers provide static accuracies up to $\pm 0.05\%$ FS with thermal stability as good as $\pm 0.005\%/^{\circ}\text{C}$. The Series 9400 incorporates an isolated diaphragm sensor which is specifically designed for use with corrosive fluids and gasses. These sensors utilize a silicon pressure cell that has been fitted into a stainless steel housing with an integral, compliant stainless steel barrier diaphragm. Standard pressure ranges are available from 0-5 psi to 0-10000 psi.

The Series 9400 achieves high accuracy and thermal stability through the use of digital algorithmic compensation which correct zero, span, and linearity errors over the operating pressure and temperature range of the pressure transducer. Each digitally compensated transducer contains an integral semiconductor memory which stores the factory calibration data. This data is uploaded into the 9022 upon power-up and is used to compensate for the inherent transducer thermal errors during use. The 9022 supplies pressure measurements from each transducer in engineering units over an Ethernet TCP or UDP interface.



9400 Pressure Transducer

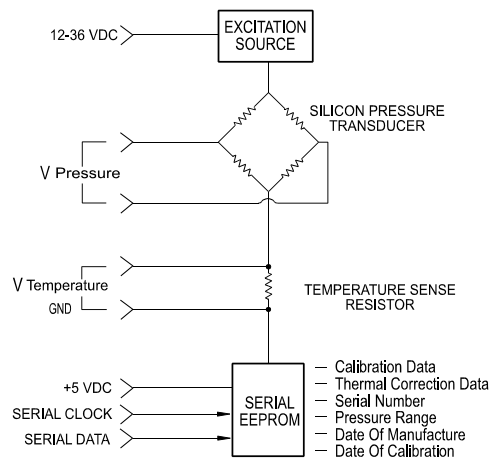

Electrical Block Diagram

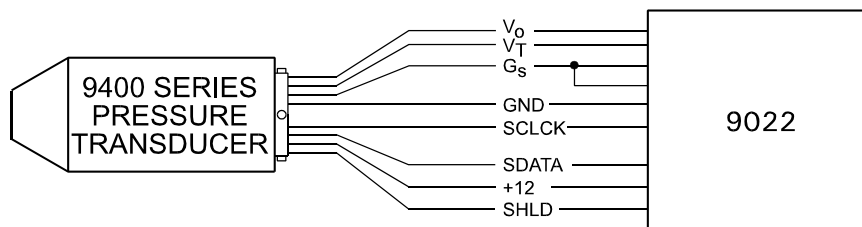

9400 CONNECTION TO 9022

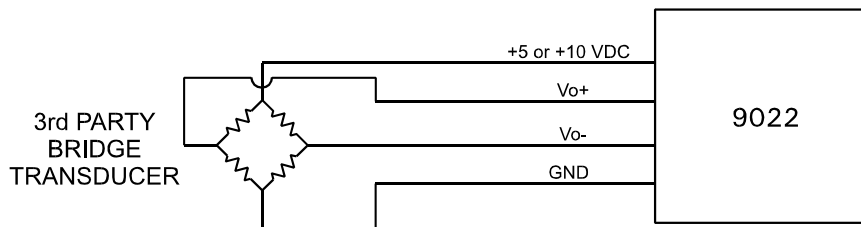

BRIDGE TRANSDUCER CONNECTION TO 9022



AGT Absolute Gauge Technologies™

Presented by: Absolute Gauge Technologies
 sales@absolute-gauge.com; www.absolute-gauge.com,
 Toronto: 416 754 3168, Montreal: 514 695 5147, Toll Free: 1 888 754 7008

The 9022 front panel contains all electrical connections required to operate the device.

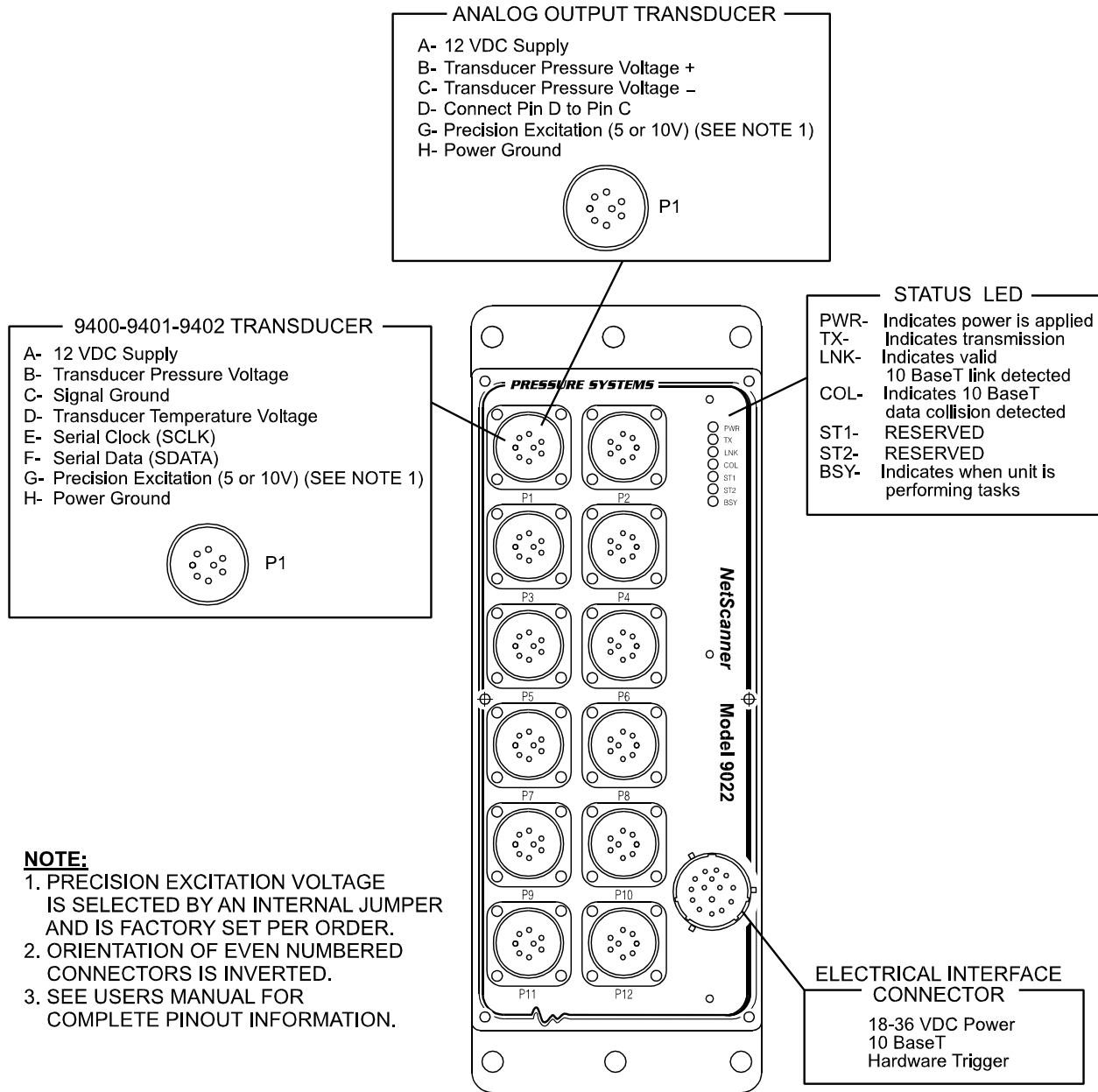

NOTE:

1. PRECISION EXCITATION VOLTAGE IS SELECTED BY AN INTERNAL JUMPER AND IS FACTORY SET PER ORDER.
2. ORIENTATION OF EVEN NUMBERED CONNECTORS IS INVERTED.
3. SEE USERS MANUAL FOR COMPLETE PINOUT INFORMATION.

The Model 9022 can be interfaced directly to a host computer or be part of a NetScanner™ System network solution.

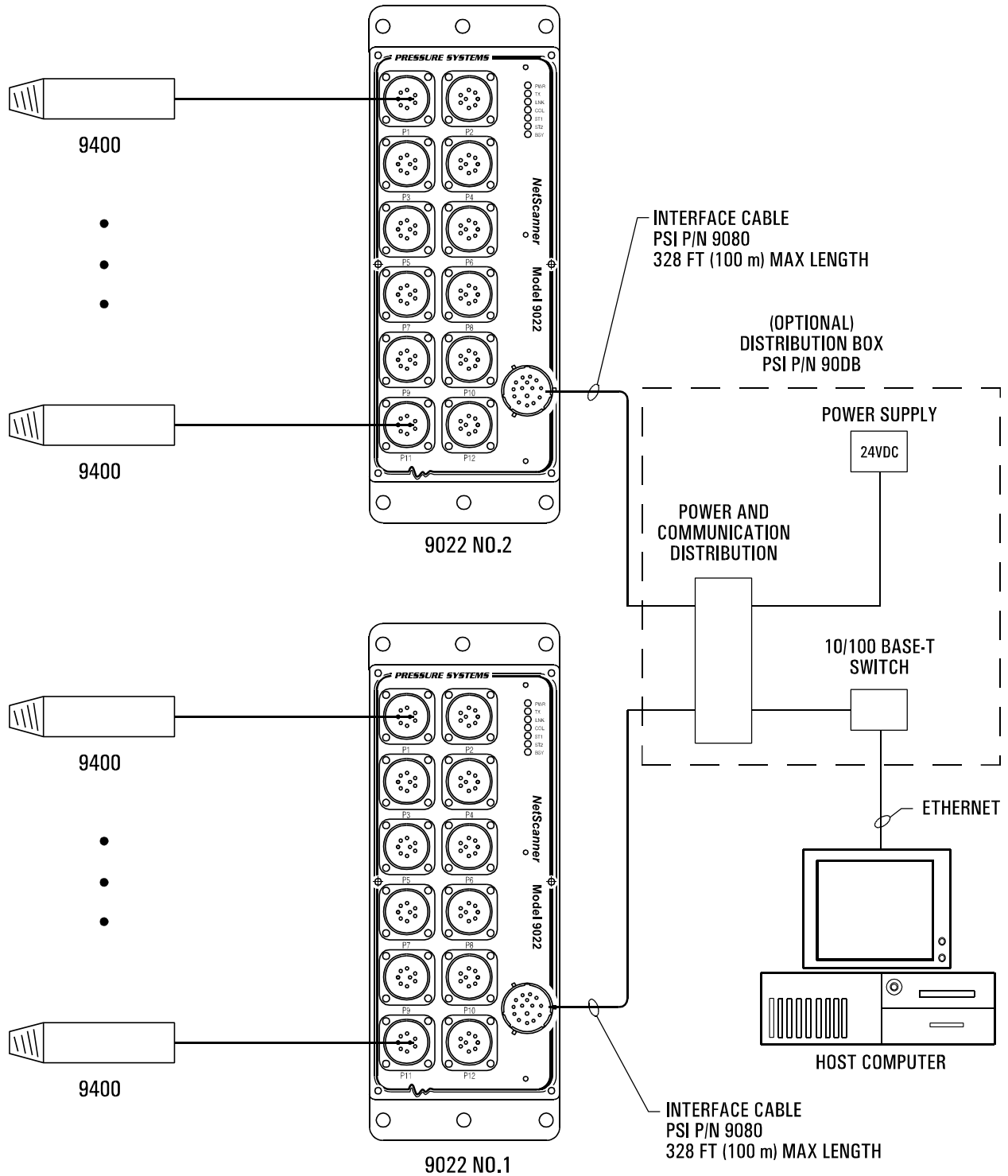

9022 Ordering/Part Number Information

Ordering Information:

PN: 9022-0101000300 9022 Ethernet All-Media Intelligent Pressure Scanner

