

BP600600

Force Platform



APPLICATIONS

The BP600600* Biomechanics Force Platform provides a square working area and a size larger than the standard AMTI OR6-7 force platform. The BP600600 can be used for biomechanics, engineering, medical research, orthopedics, rehabilitation evaluation, prosthetics, and general industrial uses. Specific uses include gait analysis, stability analysis, neurological analysis, prosthetics fitting, athletic performance, shoe design, and force, power, and work studies.

DESCRIPTION

The AMTI Biomechanics Force Platform model BP600600 features composite construction, resulting in a low-mass instrument with excellent frequency response. Specifically designed for the precise measurement of ground reaction forces, the BP600600 measures the three orthogonal force components along the X, Y, and Z axes, and the moments about the three axes, producing a total of six outputs. The high sensitivity, low crosstalk, excellent repeatability and long term stability of this platform makes it ideal for research and clinical studies. The BP600600 is easy to use and is available in a 1000, 2000, or 4000 pound (4450, 8900, or 17,800 Newton) vertical capacity.

AMPLIFICATION

The BP600600 Biomechanics Force Platform uses strain gages mounted on four precision strain elements in a patented design to measure forces and moments. As with most conventional strain gage transducers, bridge excitation and signal amplification are required. AMTI's product line includes two strain gage amplifiers to suit different application needs. AMTI's amplifiers are all stable high gain devices which provide excitation and amplification for multiple channels in one convenient package.

CALIBRATION

Each platform is inspected and tested in AMTI's calibration facility. The calibration procedure involves loading the transducer with ten point uniaxial loads at eight precise locations. These load sets are used by our calibration software to provide the six main sensitivity terms along with a calibration matrix for crosstalk compensation. The matrix is provided as an indicator of the low crosstalk and only the main diagonal terms are typically used.

SOFTWARE

Automated data collection and reduction requires a computer and software. AMTI's software package, BioAnalysis with NetForce, is specifically designed for biomechanics and clinical applications. NetForce provides a simple user interface and extensive database function for easy trial set-up and data acquisition. BioAnalysis performs a comprehensive analysis of the data and presents many summarizing parameters that can be averaged across numerous selectable trails. The BioAnalysis with NetForce software package is available separately or combined in one of AMTI's BIOVEC™ Systems.

BIOVEC™ SYSTEMS

AMTI's BIOVEC™ Systems are complete gait and balance analysis force platform systems. Each system consists of force platforms (from 1 to 4), amplifiers, cables, mounting hardware, A/D converter, and BioAnalysis software.

CUSTOM

AMTI also offers other transducers to meet your specific needs. Units with larger surface areas are available, and sensors with capacities as high as 3,000,000 pounds (13,345,000 Newtons) have also been constructed. Units are available in waterproof versions and various sizes, load capacities, sensitivities and materials.



Presented by: Absolute Gauge Technologies
sales@absolutegauge.com; www.absolutegauge.com,
Toronto: 416 754 3168, Montreal: 514 695 5147, Toll Free: 1 888 754 7008

AMTI
FORCE AND MOTION

ISO 9001:2000 certified

WIRING FOR BP600600

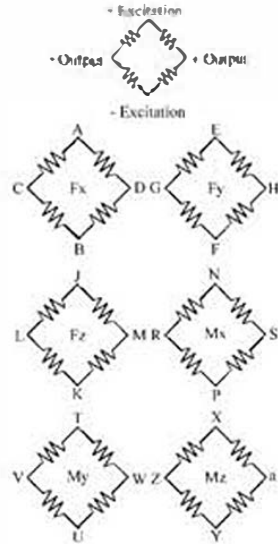

Bridge Fz = 350 ohms
 Bridges Fx; Fy; Mx; My; Mz = 700 ohms

CONNECTOR TYPE:
 Souriau 851-02E16-26P50-44

BP600600 SERIES SPECIFICATIONS	1000	2000	4000
Fz Capacity, lb (N)	1000 (4450)	2000 (8900)	4000 (17800)
Fx, Fy Capacity, lb (N)	500 (2225)	1000 (4450)	2000 (8900)
Mz Capacity, in-lb (Nm)	6000 (660)	12000 (1320)	24000 (2760)
Mx, My Capacity, in-lb (Nm)	12000 (1320)	24000 (2760)	48,000 (5520)
Fz Natural Frequency, Hz	700	780	900
Fx, Fy Natural Frequency, Hz	350	490	700
Fz Sensitivity, $\mu V/[V\text{-lb}]$ ($\mu V/[V\text{-N}]$)	0.75 (0.17)	0.38 (0.08)	0.19 (0.04)
Fx, Fy Sensitivity, $\mu V/[V\text{-lb}]$ ($\mu V/[V\text{-N}]$)	3.0 (0.67)	1.5 (0.34)	0.75 (0.17)
Mz Sensitivity, $\mu V/[V\text{-in-lb}]$ ($\mu V/[V\text{-Nm}]$)	0.30 (2.46)	0.15 (1.23)	0.08 (0.62)
Mx, My Sensitivity, $\mu V/[V\text{-in-lb}]$ ($\mu V/[V\text{-Nm}]$)	0.16 (1.52)	0.08 (0.76)	0.04 (0.38)

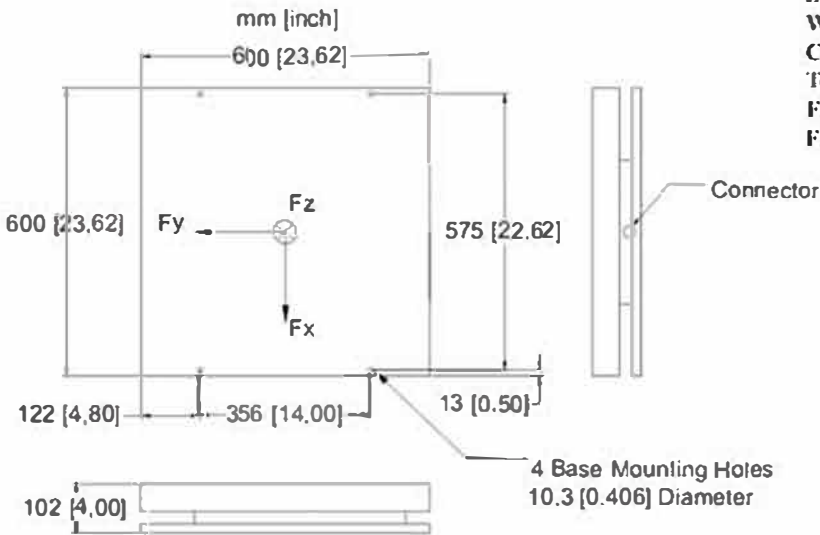

GENERAL SPECIFICATIONS

- Excitation: 10V maximum
- Weight: 60 lb (19 Kg)
- Crosstalk: Less than 2% on all channels
- Temperature Range: 0 to 125°F, (-17 to 52°C)
- Fx, Fy, Fz hysteresis: $\pm 0.2\%$ Full Scale Output
- Fx, Fy, Fz non-linearity: $\pm 0.2\%$ Full Scale Output



ISO 9001:2000 certified