

Ethernet system for pressure/force measurement

16/8 channels for strain gauges, 24-bit



MSX-E3311

16/8 differential inputs, 24-bit

For strain gauges

Simultaneous acquisition of up to 8 channels

24 V digital trigger input



Integrated Ethernet switch



*Operating temperature



ARM⁹ Technology

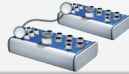

Cascadable, can be synchronised in the μ s range

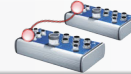

On request: Compare logic for synchro trigger signal



on request



DatabaseConnect see page 114



More information on www.addi-data.com

Features

- 24 V digital trigger input
- ARM⁹ 32-bit processor
- 64 MB onboard SDRAM for storing data
- Robust standardized metal housing
- Power Save Mode: Reduced power consumption when no acquisition runs

Safety features

- Status LEDs for fast error diagnostics
- Optical isolation
- Input filters

Inputs for strain gauges

- 16/8 differential inputs for strain gauges, 24-bit
- Sampling frequency max. 788 Hz/channel (max. 8/4 channels simultaneously)
- Autogain: Optimal adjustment of the gain to the measuring range
- Integrated sensor supply: 10 V, 50 mA (5 V optional)

Interfaces

- Fast 24 V trigger input
- Ethernet switch with 2 ports
- Synchronisation/trigger In/Out
- Line in for 24 V supply and cascading

Communication interfaces

- Web server (configuration and monitoring)
- Command server SOAP for transferring commands
- Data server (TCP/IP or UDP socket) for sending acquisition data
- Event server (TCP/IP socket) for sending system events (Diagnostics such as temperature, short-circuits ...)
- Command server Modbus TCP and Modbus (UDP) for sending commands

Synchronisation/time stamp

Time stamp

Several MSX-E systems can be synchronised with one another in the μ s range through a synchro connection. This allows to start a synchronous data acquisition, to generate trigger events and to synchronise the time on several MSX-E systems. Furthermore, the systems have a time stamp that logs the point in time at which the data was acquired by the system.

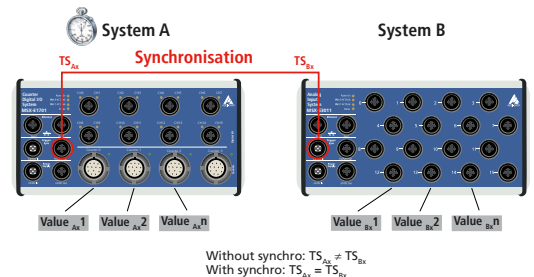

The combination of synchronisation and time stamp (TS) allows the clear allocation of signals that were captured by several systems.

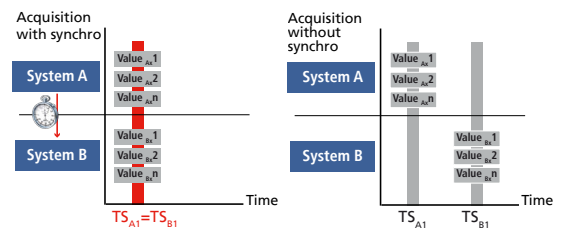



Acquisition modes

Auto-refresh mode

In auto-refresh mode, the measurement values are updated automatically after each acquisition. The acquisition is initialised once and the values of the channels are stored in the memory of the MSX-E Ethernet system. The client (e.g. PC, server, PLC, ...) reads the acquired values asynchronously to the acquisition through socket connection, SOAP or Modbus function. Thereby, the new value is read and the old values are overwritten. In addition to the measurement values, the auto-refresh counter can also be read, which allows to sort the measurement values chronologically. The auto-refresh mode can be combined with a hardware or a synchro trigger and also allows the automatic averaging of values.

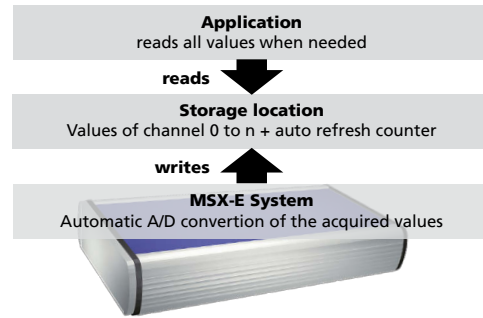

Sequence mode

In sequence mode, a list of channels is acquired. Thereby, the single measurement rows are stored one after another. The client receives the acquired values asynchronously to the acquisition through a socket connection. In the sequence mode, the measurement values are read in chronological order, this means the oldest values are read first. The acquisition can be effected continuously, with or without delay or in combination with a hardware or synchro trigger.

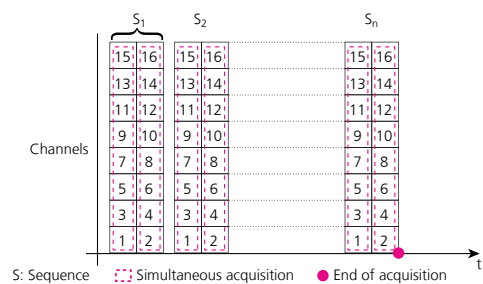

Acquisition triggered through trigger or synchro input

Example: A measurement process is to be started through an external trigger impulse. For each trigger, 10 sequences are to be acquired. After the acquisition of the 10 sequences they are to be sent to the client.

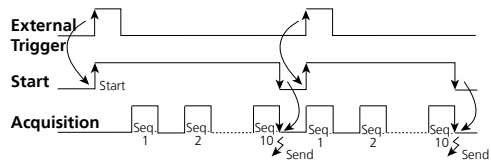

Reading data from a MSX-E system

MSX-E systems are multi-client capable, this means several clients (e. g. PC, server, PLC, ...) can read the measurement values of one MSX-E system at the same time. For this, each client establishes a socket connection to the data server of the MSX-E system (port 8989). As soon as the measurement values are available on the data server, the MSX-E system transfers them to the clients.

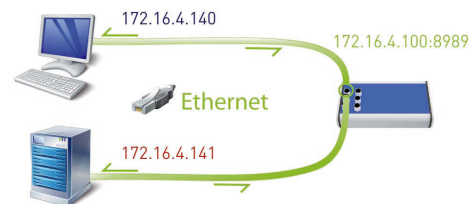

Onboard programming / stand-alone operation

Development mode

With the Development mode of the MSX-E systems you can customise your measurement, control and regulation applications to fit your requirements. The programs run directly on the MSX-E systems, which has two advantages: external PCs are relieved and you can process data freely according to your requirements. This helps you to improve the efficiency of your processes and to secure your investments.

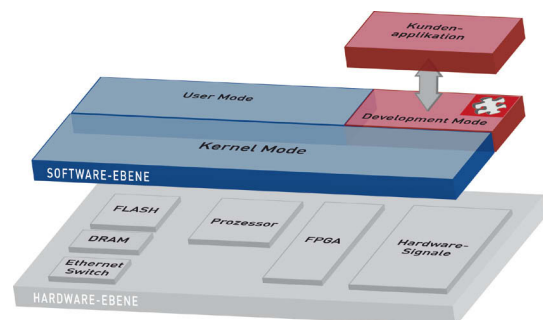

ConfigTools

The **ConfigTools** program allows an easy administration of the MSX-E systems. These are automatically detected in the network. **ConfigTools** consists of common and specific functions.

In addition, with **ConfigTools**, the complete configuration of a MSX-E system can be saved and transferred to another system of the same type (clone function).

ConfigTools is included in the delivery.

ConfigTools functions for MSX-E3311:

- Change of IP address
- Display of web interface
- Firmware update
- Save/load system configuration
- Save/load channel configuration
- Monitor for Inputs for strain gauges

Very easy use through the „ConfigTools“ program; The MSX-E system is automatically detected in the network.

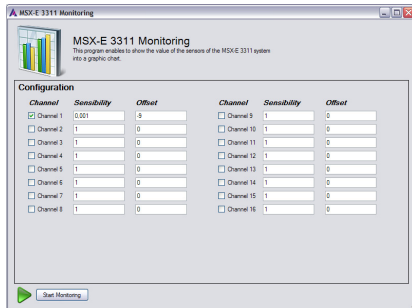
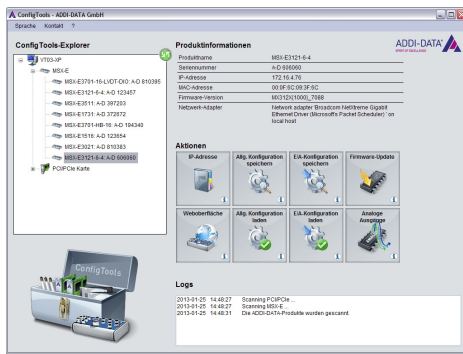

Example of monitor function for Inputs for strain gauges

Features

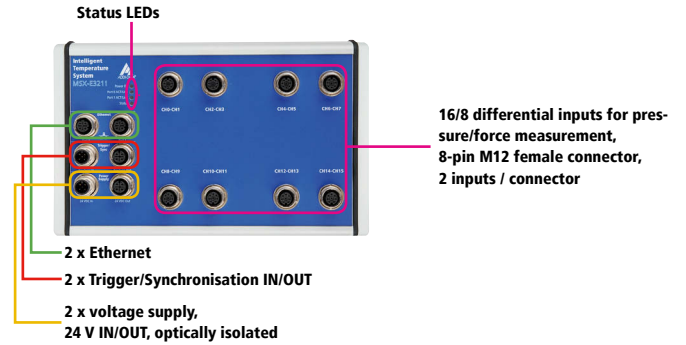

Simplified block diagram

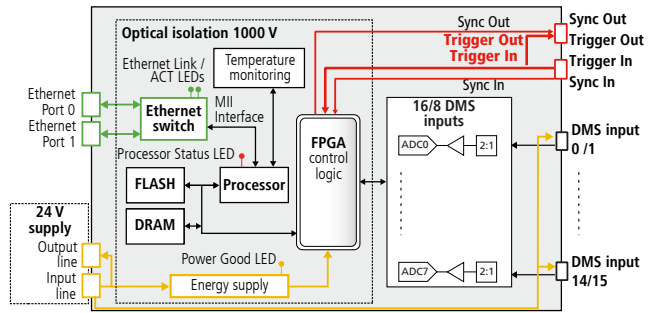

Cascading

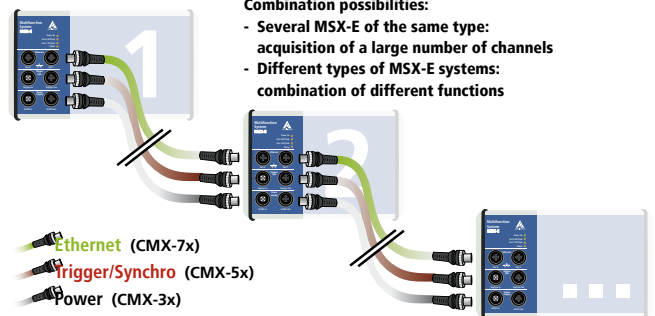

ADDI-DATA connection technology

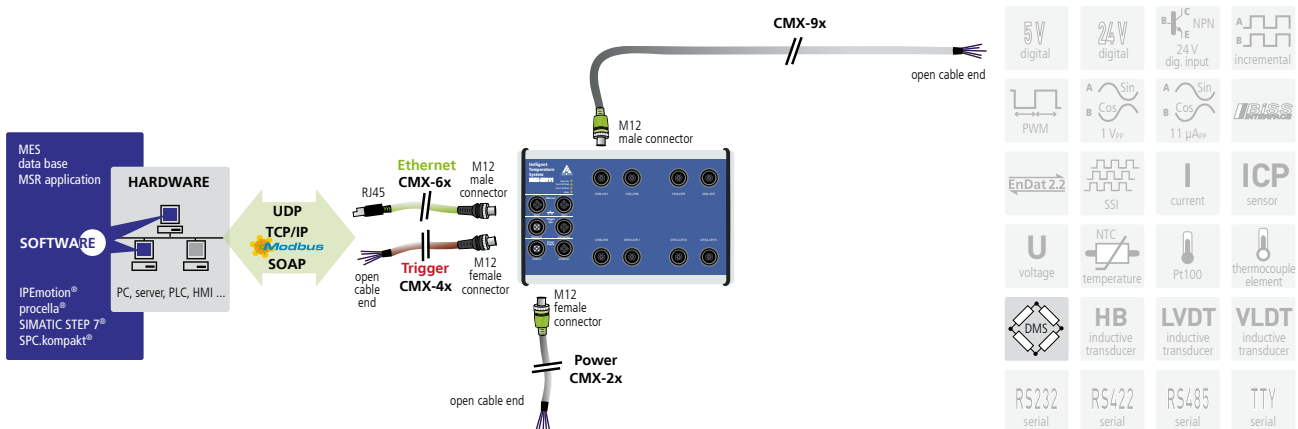



Specifications

Inputs for strain gauges

Number of inputs:	16 or 8 differential inputs for strain gauges 2 inputs per M12 connector		
Resolution:	24-bit		
Optical isolation:	1000 V		
Throughput per M12 connector:	max. 788 Hz for 1 channel, max. 528 Hz for 2 channels		
Voltage supply for the sensors:	10 V, 50 mA		
Voltage supply:	~10 V / optional 5 V (onboard calibration) 100 mA max.		
Real Sampling frequency:	on 1 channel	on 2 channels	Sampling frequency (software-configurable)
	2.37 Hz	1.585 Hz	5 Hz
	4.73 Hz	3.154 Hz	10 Hz
	9.37 Hz	6.243 Hz	20 Hz
	18.9 Hz	12.6 Hz	40 Hz
	37.35 Hz	24.89 Hz	80 Hz
	73 Hz	48.65 Hz	160 Hz
	145 Hz	96.8 Hz	320 Hz
	276.4 Hz	184.26 Hz	640 Hz
	407.83 Hz	271.96 Hz	1 kHz
	788 Hz	525.48 Hz	2 kHz

Voltage supply, Ethernet, Trigger, Synchro

The specifications for the voltage supply, Ethernet, Trigger, Synchronisation and Electromagnetic Compatibility apply to all MSX-E systems. See page 31.

System features

Interface:	Ethernet acc. to specification IEEE802.3
Dimensions:	220 mm x 140 mm x 50 mm
Weight:	620 g
Degree of protection:	IP 65
Current consumption:	150 mA ± 10 % typ. in idle/power save mode
Operating temperature:	-40 °C to +85 °C
Connectors for sensors	
Analog inputs:	8 or 4 x 8-pin female connector, M12

Ordering information

MSX-E3311

Ethernet system for pressure/force measurement, 16/8 channels for strain gauges, 24-bit. Incl. technical description, software drivers and ConfigTools.

Versions

MSX-E3311-16: for 16 strain gauges

MSX-E3311-8: for 8 strain gauges

Opt.MSX-E-5Vss: Bridge supply voltage adjustment to 5 V (**optional**)

Connection cables

Voltage supply

CMX-2x: Shielded cable, M12 5-pin female connector/open end, IP 65

CMX-3x: For cascading, shielded cable, M12 5-pin female connector/male connector IP 65

Trigger/Synchro

CMX-4x: Shielded cable, M12 5-pin female connector/open end, IP 65

CMX-5x: For cascading, shielded cable, M12 5-pin female connector/male connector IP 65

Ethernet

CMX-6x: CAT5E cable, M12 D-coded male connector/RJ45 connector

CMX-7x: For cascading, CAT5E cable, 2 x M12 D-coded male connector

Options

S7 Modbus TCP Client Library for S7: Easy use of the Ethernet systems MSX-E with PLCs

MSX-E 5V-Trigger: Level change of the trigger inputs and outputs to 5 V

MX-Rail (please specify when ordering!), **MX-Screw**, **PCMX-1x**