



8B

Module Dimensions and Pinouts

Description

The following mechanical drawing is useful when designing circuit boards to mount the 8B modules. Many sockets are available which accept the mounting pins. As an example, Mill-Max provides a socket with part

number 0660. The captive nut for the 4-40 mounting screw can be obtained from PEM (Penn Engineering and Manufacturing), part number KFS2-440.

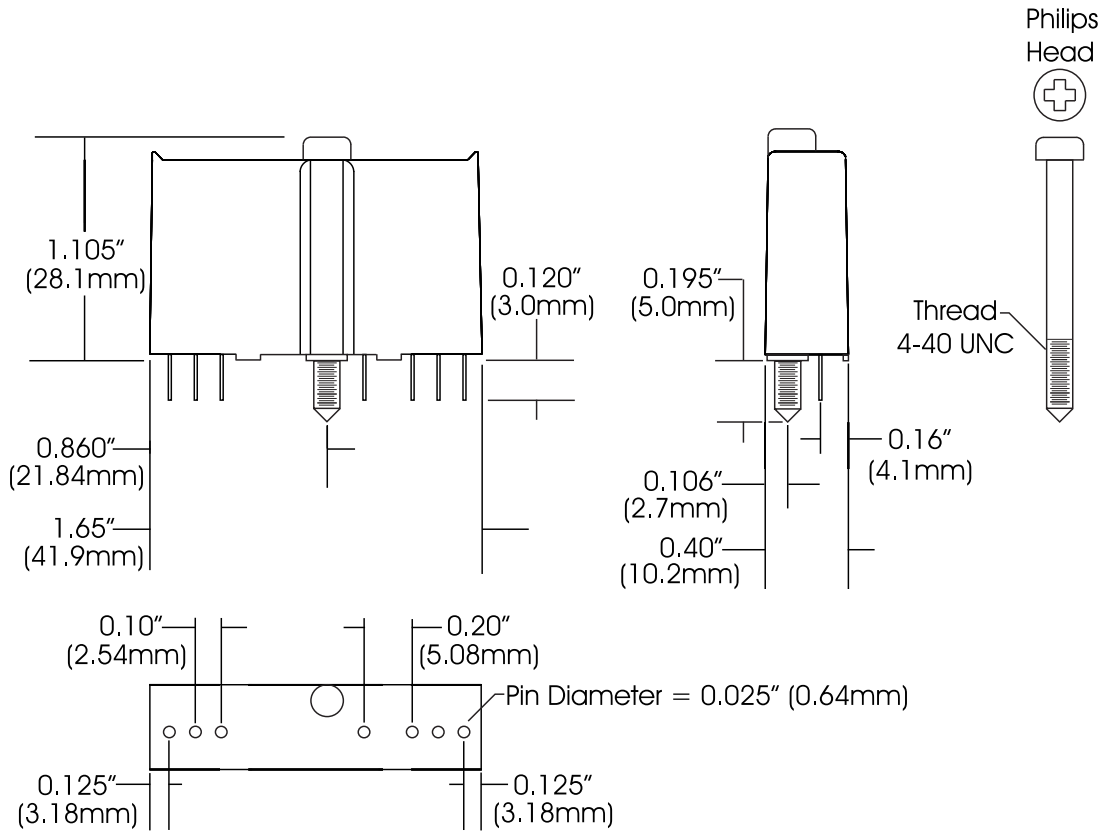

NOTE:
All dimensions are "Typical" unless otherwise noted.

Input/Output Module

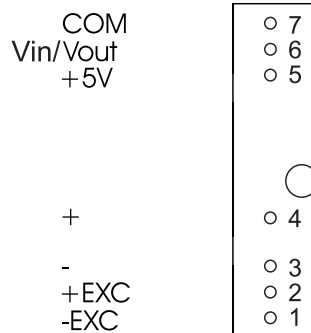

BOTTOM VIEW