

DYTRAN PROPRIETARY AND CONFIDENTIAL  
 THE INFORMATION CONTAINED IN THIS DRAWING IS THE SOLE PROPERTY OF  
 DYTRAN INSTRUMENTS, INC. AND ANY REPRODUCTION IN PART OR AS A  
 WHOLE OR ANY OTHER DISSEMINATION OF THIS INFORMATION WITHOUT THE  
 WRITTEN PERMISSION OF DYTRAN INSTRUMENTS, INC. IS PROHIBITED.

REV	ECN	DESCRIPTION	BY/DATE	CHK	APPR
A	9527	INITIAL RELEASE	RA, 01/17/13	91	[Signature]

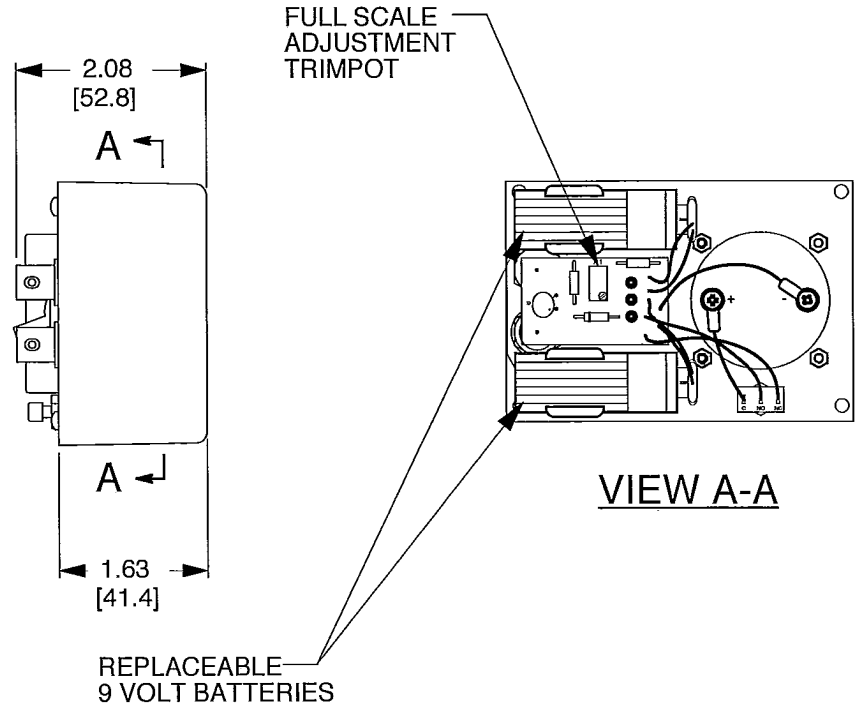
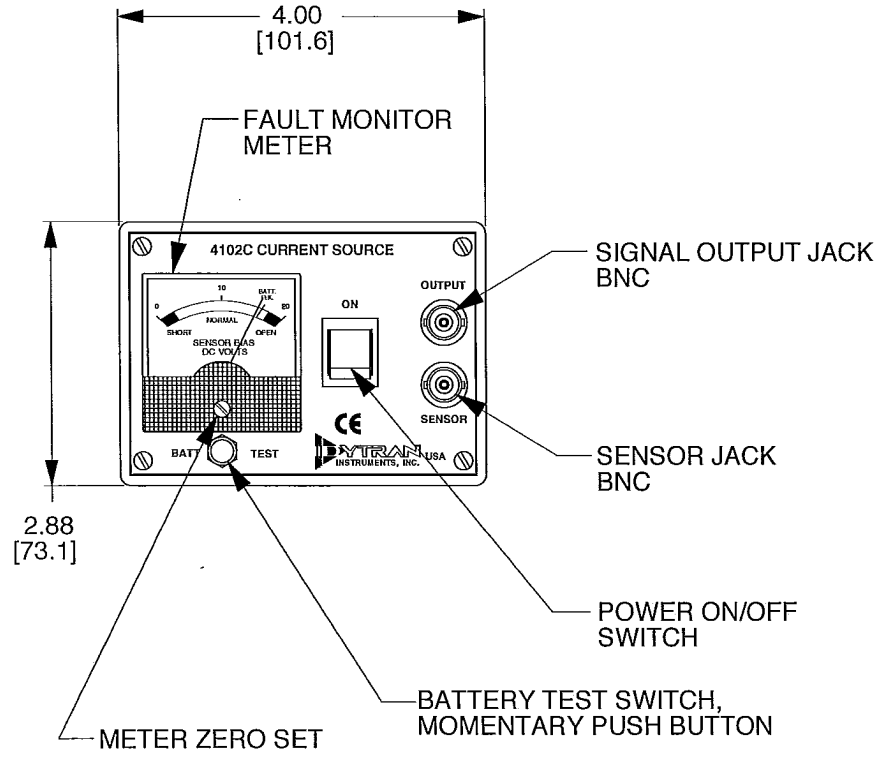

- 2. VOLTAGE AT "BATT. O.K." MARK IS 17 VDC.
  - 1. WEIGHT - 279 GRAMS (11 oz.).
- NOTES: UNLESS OTHERWISE SPECIFIED

UNLESS OTHERWISE SPECIFIED: INTERPRET DIM & TOL PER ASME Y14.5M-1994.REMOVE BURRS COUNTERSINKS INTERNAL THDS 90° TO MAJOR DIA CHAM EXT THDS 45° TO MAJOR DIA THD LENGTHS AND DEPTHS ARE FOR THDS PER MIL-S- 7742. DIMENSIONS APPLY AFTER FINISHING.	CONTRACT NO
ALL MACHINED SURFACES TOTAL RUNOUT WITHIN .005 BREAK SHARP EDGES .005 TO .010 MACHINE FILLET RADI .005 TO .015. WELDING SYMBOLS PER AWS A2.4 ABBREVIATIONS PER MIL-STD-12	UNLESS OTHERWISE SPECIFIED DIMENSIONS ARE IN INCHES. DIMENSION IN BRACKETS [ ] ARE IN MILLIMETERS. TOLERANCES ARE: INCHES METRIC ANGLES .XX ± .03 .X ± 0.8 ± 1° .XXX ± .010 .XX ± 0.25
USED ON	NEXT ASSY
APPLICATION	
THIRD ANGLE PROJECTION USA	FINISH
	DO NOT SCALE DRAWING

**DYTRAN INSTRUMENTS, INC.** **MASTER ONLY IF IN RED** CHATSWORTH, CA.

SCALE 1/2X	DESIGN NC	DATE 01/16/13		
DRAWN RA	DATE 01/16/13	PART NO. MODEL 4102C		
CHECKED	DATE	MAT'L -		REV A
APPROVED [Signature]	DATE 2/5/13	NEXT ASSEMBLY -	USED ON	
TITLE <b>OUTLINE/INSTALLATION, MODEL 4102C</b>			DWG NO. <b>127-4102C</b>	
			SHEET 1 OF 1	

## SPECIFICATIONS

### MODEL 4102C CURRENT SOURCE POWER UNIT, BATTERY POWERED

SPECIFICATION	VALUE	UNITS
SENSOR SUPPLY CURRENT, FIXED, NOM.	2.0	mA
COMPLIANCE VOLTAGE	+18	VDC
VOLTAGE GAIN	N/A	
COUPLING TIME CONSTANT INTO 10 MEGOHM LOAD	10	SEC
COUPLING TIME CONSTANT INTO 1 MEGOHM LOAD	5	SEC
LOW FREQUENCY -3db FREQ., 10 MEGOHM LOAD	0.016	Hz
LOW FREQUENCY -3db FREQ., 1 MEGOHM LOAD	.032	Hz
HIGH FREQUENCY RESPONSE	DETERMINED BY SENSOR, CABLE LENGTH AND SIGNAL LEVEL	
COUPLING CAPACITOR, NOM.	10	μF
PULLDOWN RESISTOR	1.0	MEGOHMS
MONITOR VOLTMETER RANGE, F.S.	20	VDC
ELECTRICAL NOISE, WIDEBAND	60	μV, RMS
SENSOR CONNECTOR	BNC	JACK
OUTPUT CONNECTOR JACK	BNC	
POWER SOURCE	9 VOLT BATTERIES	2
BATTERY LIFE, TYP.	80	HOURS
SIZE (H x W x D)	2 x 4 x 3	INCHES

Note: Any type of transistor radio 9-Volt battery may be use to power the 4102C. However, longest battery life will be obtained by use of high-grade alkaline type batteries.