

# Communications Modules

Provide Connection, Power, Interface

## Description

The MAQ20 communications module is offered in two models and provides the connection between a host computer and a MAQ®20 Data Acquisition System. MAQ20-COM4 communicates using Ethernet, USB, or RS-485; MAQ20-COM2 uses Ethernet, USB, or RS-232. Ethernet communications use the Modbus TCP protocol and USB communications are based on the Modbus RTU protocol, which RS-485 and RS-232 communications also use. Serial communications over RS-485 can be either 2-wire or 4-wire.

When using the Ethernet interface, up to four simultaneous socket connections are supported and each socket can process up to four simultaneous Modbus TCP transactions. Serial communications over RS-232 or RS-485 can be run at baud rates as fast as 921.6kbps.

A very useful feature of the MAQ20 system is the capability to store acquired data locally for later analysis. This is provided by the easily accessible and removable 4GB micro-SD memory card that is in the MAQ20-COMx module and can be used to log data acquired from all input modules.

Each MAQ20-COMx module can interface to up to 24 I/O modules in any combination, allowing high channel counts and great flexibility in system configuration.

To power the system, a 7-34VDC power source is connected to the communications module. Regulated and protected supplies within the module then provide power both to the internal circuits and to all I/O modules in the system. When many high power I/O modules are used in a system, MAQ20-PWR3 load-sharing boost power supply modules can be installed in standard I/O module slots to provide the necessary additional power.

## ► Features

- Connect Host Computer and MAQ®20 System
- Communicate using Ethernet, USB, RS-485, RS-232
- Up to 4 Simultaneous Socket Connections with Ethernet
- Baud Rates to 921.6kbps with RS-232/RS-485
- Follow Modbus TCP or RTU Protocols
- Store Acquired Data Locally
- Interface to up to 24 I/O Modules
- 50VDC Communications Interface-to-Bus Isolation

To ensure robustness, the communications interface-to-bus isolation is 50VDC and power input terminals are protected against overvoltage, transient, and reverse connections.

As a minimum, a MAQ®20 Data Acquisition System must have a communications module, a backbone, and one I/O module.

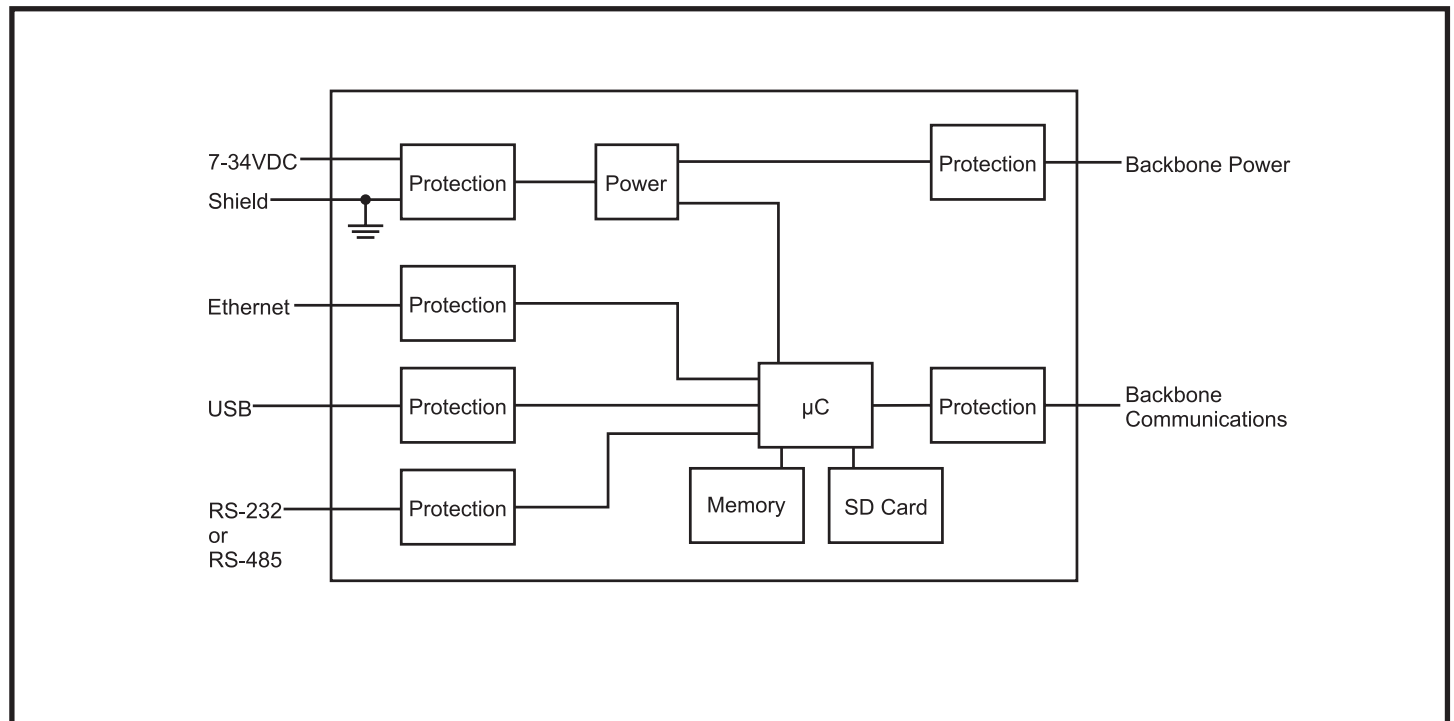

Figure 1: MAQ20 Communications Module Block Diagram

**Specifications**

Module	Description
MAQ20-COM4 MAQ20-COM2	Ethernet, USB, RS-485 Ethernet, USB, RS-232
Communications Ethernet USB RS-485 RS-232	10/100 Base-T (1000 Base-T compatible) RJ-45, Modbus TCP USB 2.0, Type B, Proprietary Modbus over USB 2-wire or 4-wire, up to 921.6kbps, up to 4000 ft, RJ-45, Modbus RTU Up to 921.6kbps, RJ-45, Modbus RTU
CMV Power-to-Bus Communication Port-to-Bus Transient	50VDC 50VDC ANSI/IEEE C37.90.1
Power Supply Input Power Power to Bus	7-34VDC at 2A max 5VDC at 3A max
Dimensions (h)(w)(d)	4.51" x 1.11" x 3.26" (114.6mm x 28.2mm x 82.8mm)
Environmental Operating Temperature Storage Temperature Relative Humidity Emissions, EN61000-6-4 Radiated, Conducted Immunity EN61000-6-2 RF ESD, EFT	-40°C to +85°C -40°C to +85°C 0 to 95% Noncondensing ISM Group 1 Class A ISM Group 1 Performance A Performance B
Certifications	Heavy Industrial CE, ATEX Pending UL/CUL Class I, Division 2, Groups A, B, C, D Pending

**Ordering Information**

Model	Description
MAQ20-COM4	Ethernet, USB, RS-485
MAQ20-COM2	Ethernet, USB, RS-232



Figure 2: Communications Module

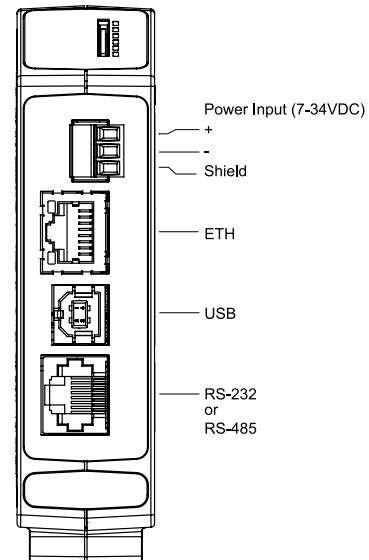

Figure 3: Communications Module Input Connections

**For full details on module operation, refer to MA1040 – MAQ20 Communications Module Hardware User Manual, available for download at: [www.dataforth.com/maq20\\_download.aspx](http://www.dataforth.com/maq20_download.aspx)**