

# MV-SC6050C

## 5 MP Smart Camera



### Introduction

MV-SC6050C smart camera is developed based on high-performance embedded platform with strong calculation performance. It integrates VM functions and AI deep learning algorithm, and can use more than 140 algorithms. It adopts multiple interfaces for supporting external light source, display, mouse, etc.

### Available Model

- 8 mm focal length smart camera:  
MV-SC6050C-08M-XBN
- 12 mm focal length smart camera:  
MV-SC6050C-12M-XBN
- 16 mm focal length smart camera:  
MV-SC6050C-16M-XBN

### Applicable Industry

Consumer electronics, food and pharmaceutical, packaging, positioning and grabbing, etc.

### Dimension

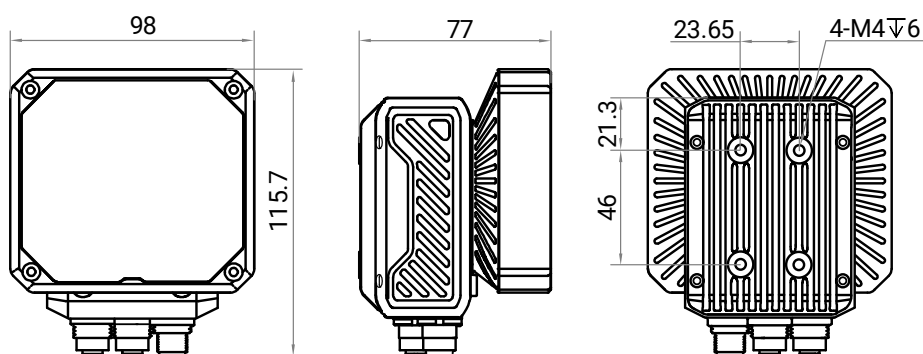

Unit: mm

### Key Feature

- Adopts AI deep learning algorithm to achieve OCR, object recognition, defect detection, etc.
- Integrates VM functions and supports more than 140 algorithms.
- Supports four-color light source (red/green/blue/white), and switching as needed.
- Adopts multiple I/O interfaces, such as multiple input/output signals.
- Supports multiple communication protocols.
- Supports indicators displaying device status for easy debugging and maintenance.
- Supports ingress protection IP67.

## Specification

Model	MV-SC6050C-08M-XBN	MV-SC6050C-12M-XBN	MV-SC6050C-16M-XBN
<b>Tool</b>			
Function module	VM Platform		
Communication protocol	TCP, UDP, ModBus, Serial Port, Profinet, EtherNet/IP, Fins, MC, FTP, etc.		
<b>Camera</b>			
Sensor type	CMOS, global shutter		
Pixel size	3.45 $\mu\text{m}$ $\times$ 3.45 $\mu\text{m}$		
Sensor size	1/1.45"		
Resolution	2432 $\times$ 2048		
Max. frame rate	80 fps		
Gain	0 dB to 18 dB		
Exposure time	16 $\mu\text{s}$ to 1 sec		
Pixel format	Mono 8, RGB 8		
Mono/color	Color		
<b>Platform</b>			
Memory	8 GB		
Storage	64 GB		
<b>Electrical feature</b>			
Data interface	Gigabit Ethernet (1000 Mbit/s)		
Digital I/O	17-pin M12 male connector provides power and I/O, providing opto-isolated input $\times$ 2 (Line 0/1), opto-isolated output $\times$ 2 (Line 4/5), configurable non-isolated input/output $\times$ 2 (Line 2/3), RS-232 $\times$ 1, light source output (max. 30 W) $\times$ 1		
Extended interface	17-pin M12 female connector provides VGA $\times$ 1 and USB host $\times$ 1		
Power supply	24 VDC		
Power consumption	Approx. 12 W @ 24 VDC (without external light source) Approx. 42 W @ 24 VDC (with external light source) Approx. 16.6 W @ 24 VDC (light source is enabled)		
<b>Mechanical</b>			
Lens mount	M12-mount		
Focal length	8 mm	12 mm	16 mm
Light source	Red light, green light, blue light, white light (switching by software)		
Indicator	Power indicator (PWR), network indicator (LNK), status indicator (STS), and user-defined indicator (U1/U2)		
Dimension	77 mm $\times$ 98 mm $\times$ 115.7 mm (3.0" $\times$ 3.9" $\times$ 4.6")		
Weight	Approx. 750 g (1.7 lb.)		
Ingress protection	IP67 (under proper installation of waterproof lens cap)		
Temperature	Working temperature: 0 $^{\circ}\text{C}$ to 50 $^{\circ}\text{C}$ (32 $^{\circ}\text{F}$ to 122 $^{\circ}\text{F}$ ) Storage temperature: -30 $^{\circ}\text{C}$ to 70 $^{\circ}\text{C}$ (-22 $^{\circ}\text{F}$ to 158 $^{\circ}\text{F}$ )		
Humidity	20% RH to 95% RH, no condensation		
<b>General</b>			
Certification	CE, KC		

## Detection Range

Focal Length	Installation Distance	Field of View	Single Pixel Accuracy
8 mm	100 mm	100 mm × 88 mm	0.043 mm
	2000 mm	2000 mm × 1750 mm	0.863 mm
12 mm	100 mm	70 mm × 60 mm	0.029 mm
	2000 mm	1400 mm × 1180 mm	0.575 mm
16 mm	100 mm	52 mm × 44 mm	0.022 mm
	2000 mm	1050 mm × 883 mm	0.431 mm

