

MV-ID5200M-00C-NNN

20 MP Smart Code Reader



Introduction

MV-ID5200M-00C-NNN smart code reader can read different types of codes with reading speed up to 36 codes/sec. It adopts CMOS sensor and deep learning algorithm to process image with good robustness, and can recognize various codes.

Key Feature

- Adopts CMOS sensor to acquire image data and provide high-quality image.
- Adopts built-in deep learning algorithm to read codes with good robustness.
- Supports code quality evaluation to detect the printing quality of codes.
- Supports multiple communication protocols, including Serial, FTP, Profinet, Fins, etc.
- Supports RS-232 serial port and indicators displaying device status.

Available Model

MV-ID5200M-00C-NNN

Applicable Industry

Consumer electronics, food and beverage, pharmaceutical, semiconductor, automobile, new energy, etc.

Accessories

KF series lens: MVL-KF3528M-12MP

Dimension

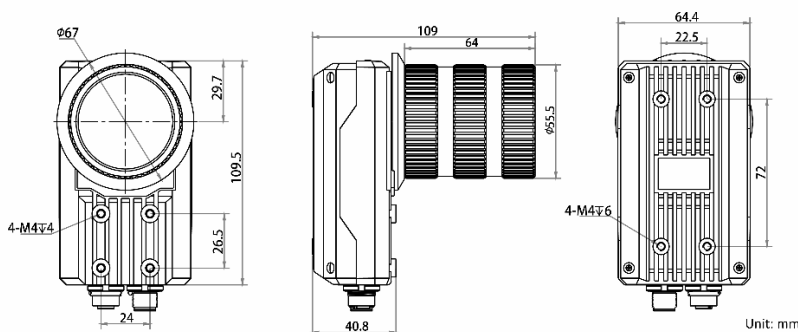

Specification

Model	MV-ID5200M-00C-NNN
Performance	
Symbologies	1-dimensional codes: Code 39, Code 93, Code 128, CodaBar, EAN 8, EAN 13, UPCA, UPCE, ITF 14, ITF 25, Matrix 25, MSI, China Post, Code 11
	2-dimensional codes: QR Code, Data Matrix
	Stack codes: PDF 417
Max. frame rate	20 fps
Max. reading speed	36 codes/sec
Sensor type	CMOS, rolling shutter
Pixel size	2.4 μm \times 2.4 μm
Sensor size	1"
Resolution	5440 \times 3648
Exposure time	16 μs to 500 ms
Gain	0 dB to 40 dB
Mono/color	Mono
Communication protocol	SmartSDK, TCP Client, Serial, FTP, TCP Server, Profinet, Ethernet/IP, MELSEC, Fins, ModBus, SLMP, UDP
Electrical feature	
Data interface	Gigabit Ethernet
Digital I/O	12-pin M12 connector provides power and I/O, including opto-isolated input (LineIn 0/1/2) \times 3, opto-isolated output (LineOut 3/4/5) \times 3, RS-232 input \times 1, and RS-232 output \times 1.
Power supply	12 VDC to 24 VDC
Max. power consumption	12 W@24 VDC
Mechanical	
Lens mount	C-mount
Light source	Not included
Lens cap	Transparent lens cap. Polarization lens cap is optional.
Indicator	Power indicator (PWR), network indicator (LNK/ACT), and user-defined indicator (U1/U2).
Dimension	109.5 mm \times 64.4 mm \times 109 mm (4.3" \times 2.5" \times 4.3")
Weight	Approx. 470 g (1.0 lb.)
Ingress protection	IP67 (under proper installation of waterproof lens cap)
Temperature	Working temperature: 0 $^{\circ}\text{C}$ to 50 $^{\circ}\text{C}$ (32 $^{\circ}\text{F}$ to 122 $^{\circ}\text{F}$) Storage temperature: -30 $^{\circ}\text{C}$ to 70 $^{\circ}\text{C}$ (-22 $^{\circ}\text{F}$ to 158 $^{\circ}\text{F}$)
Humidity	20% to 95% RH, non-condensing
General	
Client software	IDMVS
Certification	CE, FCC, RoHS, KC