

PROPRIETARY AND CONFIDENTIAL

THE INFORMATION CONTAINED IN THIS DRAWING IS THE SOLE PROPERTY OF DYTRAN INSTRUMENTS INC. ANY REPRODUCTION IN PART OR AS A WHOLE WITHOUT THE WRITTEN PERMISSION OF DYTRAN INSTRUMENTS INC. IS PROHIBITED

REVISIONS

| REV. | ECN | DESCRIPTION | BY/DATE | CHK | APPR |
|------|-------|-----------------|----------------|-----|------|
| A | 11357 | INITIAL RELEASE | JS 10/01/14 | EM | |

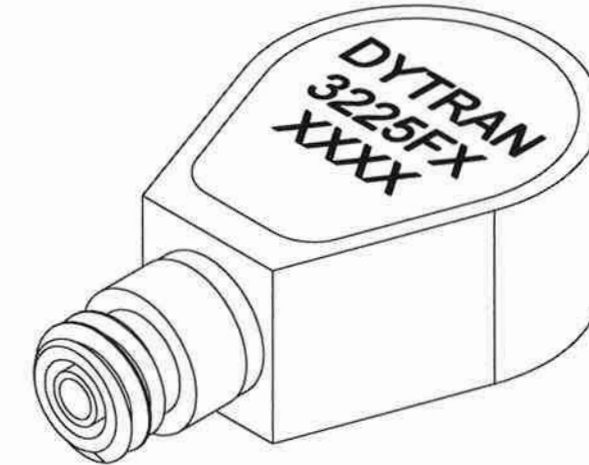
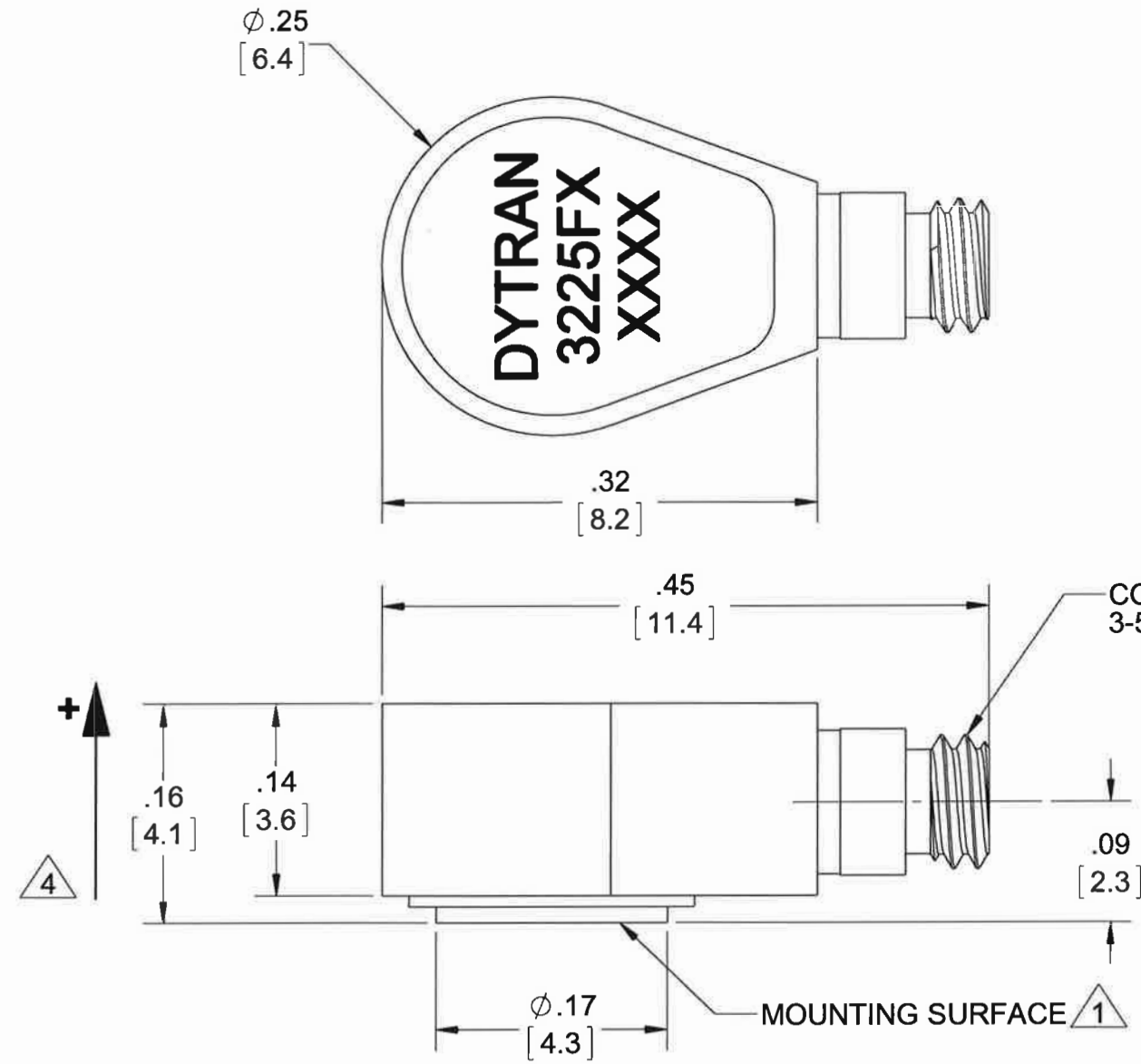

| MODEL NO. | REV | ECN | DATE | SENSITIVITY |
|-----------|-----|-------|----------|-------------|
| 3225F4 | A | 11357 | 09/11/14 | 1 mV/g |
| 3225F5 | A | 11357 | 09/11/14 | 10 mV/g |
| 3225F6 | A | 11357 | 09/11/14 | 5 mV/g |

5. LOW OUT-GASSING

4 ARROW INDICATES DIRECTION OF ACCELERATION FOR POSITIVE OUTPUT

3. CASE AND CONNECTOR MATERIAL: TITANIUM.

2. WEIGHT: 0.6 GRAMS MAX.

1 RECOMMENDED MOUNTING ADHESIVE: CYANOACRYLATE OR DYTRAN MOUNTING WAX MODEL 6273

NOTES: UNLESS OTHERWISE SPECIFIED

UNLESS OTHERWISE SPECIFIED:
 INTERPRET DIM & TOL PER ASME Y14.5M - 1994.
 REMOVE BURRS.
 COUNTERSINK INTERNAL THDS 90° TO MAJOR DIA.
 CHAM EXT THDS 45° TO MINOR DIA.
 THD LENGTHS AND DEPTHS ARE FOR MIN FULL THDS.
 DIMENSIONS APPLY AFTER FINISHING.

UNLESS OTHERWISE SPECIFIED:
 DIMENSIONS ARE IN INCHES.
 DIMENSIONS IN BRACKETS [] ARE IN MILLIMETERS TOLERANCES ARE:

| DECIMALS | METRIC | ANGLES |
|-------------|------------|--------|
| .XX ± .03 | .X ± 0.8 | ± 1° |
| .XXX ± .010 | .XX ± 0.25 | |

APPROVALS

| ORIG | EC | DATE |
|------|----|----------|
| | | 09/03/14 |
| CHK | EM | 10/3/14 |
| APP | | 10/3/14 |

ALL MACHINED SURFACES. ⁶³✓
 TOTAL RUNOUT WITHIN .005.
 BREAK SHARP EDGES .005 TO .010.
 MACHINED FILLET RADII .005 TO .015.
 WELDING SYMBOLS PER AWS A2.4.
 ABBREVIATIONS PER MIL-STD-12.

DO NOT SCALE DRAWING

THIRD ANGLE PROJECTION USA

MASTER ONLY IF IN RED
 DYTRAN INSTRUMENTS, INC. Chatsworth, CA

TITLE: OUTLINE/INSTALLATION DRAWING, MODEL 3225F4

| SIZE | CAGE CODE | DWG NO | REV |
|------|-----------|------------|-----|
| B | 2W033 | 127-3225F4 | A |

SCALE: 8:1 SHEET 1 OF 1

