



# 8B47

## Linearized Thermocouple Input Modules

### Description

8B modules are an optimal solution for monitoring real-world process signals and providing high-level signals to a data acquisition system. Each 8B47 module isolates, filters, amplifies, and linearizes a single channel of temperature input from a thermocouple and provides an analog voltage output (Figure 1).

Linearization is accomplished using a four breakpoint piecewise linear approximation.

The 8B47 can interface to industry standard thermocouple types J, K, and T and has an output signal of 0 to +5V. Each module is cold-junction compensated to correct for parasitic thermocouples formed by the thermocouple wire and screw terminals on the mounting backpanel. Upscale open thermocouple detect is provided by an internal pull-up resistor.

Signal filtering is accomplished with a 3-pole filter optimized for time and frequency response which provides 70dB of normal-mode rejection at 60Hz. One pole of this filter is on the field side of the isolation barrier for anti-aliasing, and the other two are on the system side.

A special input circuit on the 8B47 module provides protection against accidental connection of power-line voltages up to 240VAC. Clamp circuits on the I/O and power terminals protect against harmful transients.

The modules are designed for installation in Class I, Division 2 hazardous locations and have a high level of immunity to environmental noise.

### Features

- Interfaces to Types J, K, and T Thermocouples
- Linearizes Thermocouple Signal
- High-Level Voltage Outputs
- 1500Vrms Isolation
- ANSI/IEEE C37.90.1 Transient Protection
- Input Protection to 240VAC Continuous
- 120dB CMR
- 70dB NMR at 60Hz
- Low Drift with Ambient Temperature
- Accurate CJC -40°C to +85°C
- C-UL-US Listed
- CE Compliant
- ATEX Compliance Pending
- Mix and Match Module Types on Backpanel

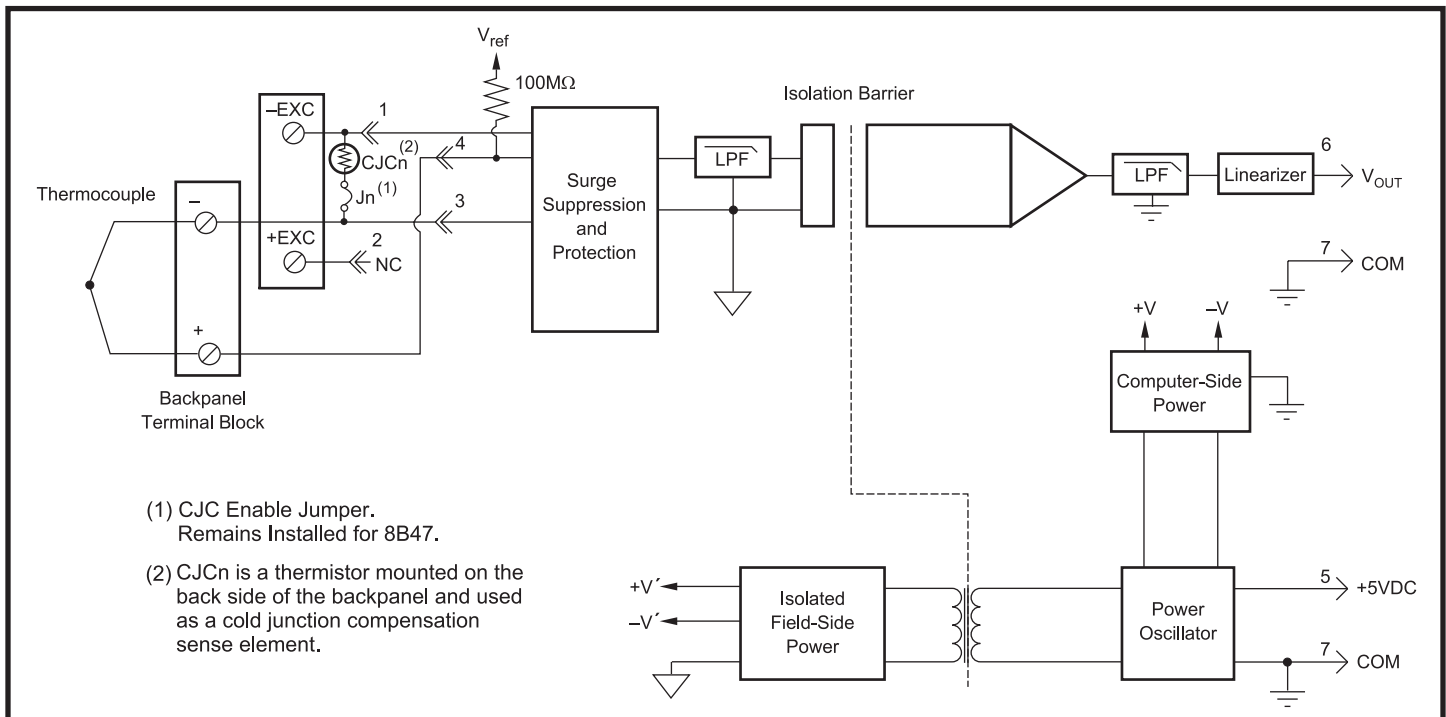

Figure 1: 8B47 Block Diagram



**Specifications** Typical\* at T<sub>A</sub>=+25°C and +5VDC power

Module	8B47
Input Range	-0.1V to +0.5V
Input Bias Current	-25nA
Input Resistance	
Normal	50MΩ
Power Off	200kΩ
Overload	200kΩ
Input Protection	
Continuous <sup>(1)</sup>	240VAC
Transient	ANSI/IEEE C37.90.1
CMV, Input to Output	1500Vrms max
Transient, Input to Output	ANSI/IEEE C37.90.1
CMR (50Hz or 60Hz)	120dB
NMR	70dB at 60Hz
Accuracy	See Ordering Information
Stability	
Offset	±20ppm/°C
Gain	±75ppm/°C
Noise	
Output, 100kHz	250μVrms
Bandwidth, -3dB	3Hz
Response Time, 90% Span	150ms
Output Range	0V to +5V
Output Protection	Continuous Short to Ground
Transient	ANSI/IEEE C37.90.1
Cold Junction Compensation	
Accuracy, 25°C	±0.5°C
Accuracy, -40°C to +85°C	±1.5°C
Open Input Response	Upscale
Open Input Detection Time	<10s
Power Supply Voltage	+5VDC ±5%
Power Supply Current	30mA
Power Supply Sensitivity	±100ppm/%
Mechanical Dimensions (h)(w)(d)	1.11" x 1.65" x 0.40" (28.1mm x 41.9mm x 10.2mm)
Environmental	
Operating Temperature Range	-40°C to +85°C
Storage Temperature Range	-40°C to +85°C
Relative Humidity	0 to 95% Noncondensing
Emissions EN61000-6-4	ISM, Group 1
Radiated, Conducted	Class A
Immunity EN61000-6-2	ISM, Group 1
RF	Performance A ±0.5% Span Error
ESD, EFT	Performance B

**NOTES:**

\*Contact factory or your local Dataforth sales office for maximum values.

(1) 240VAC between +Input terminal and -Input, +EXC, or -EXC terminals.

120VAC between -Input and +EXC or -EXC terminals.

120VAC between +EXC and -EXC terminals.

(2) Includes conformity, hysteresis and repeatability. Does not include CJC accuracy.

**Ordering Information**

Model	TC Type <sup>‡</sup>	Input Range	Output Range	Accuracy <sup>(2)</sup>	
8B47J-01	J	0°C to +760°C (+32°F to +1400°F)	0V to +5V	±0.10%	±1.82°C
8B47J-02	J	-100°C to +300°C (-148°F to +572°F)	0V to +5V	±0.20%	±0.96°C
8B47J-03	J	0°C to +500°C (+32°F to +932°F)	0V to +5V	±0.20%	±1.05°C
8B47J-12	J	-100°C to +760°C (-148°F to +1400°F)	0V to +5V	±0.20%	±2.10°C
8B47K-04	K	0°C to +1000°C (+32°F to +1832°F)	0V to +5V	±0.15%	±2.40°C
8B47K-05	K	0°C to +500°C (+32°F to +932°F)	0V to +5V	±0.15%	±1.05°C
8B47K-13	K	-100°C to +1350°C (-148°F to +2462°F)	0V to +5V	±0.15%	±3.60°C
8B47K-14	K	0°C to +1200°C (+32°F to +2192°F)	0V to +5V	±0.15%	±2.88°C
8B47T-06	T	-100°C to +400°C (-148°F to +752°F)	0V to +5V	±0.20%	±2.40°C
8B47T-07	T	0°C to +200°C (+32°F to +392°F)	0V to +5V	±0.20%	±0.75°C

**‡ Thermocouple Alloy Combinations**

Standards: DIN IEC 584, ANSI MC96-1-82, JIS C 1602-1981

Type	Material
J	Iron vs. Copper-Nickel
K	Nickel-Chromium vs. Nickel-Aluminum
T	Copper vs. Copper-Nickel

