



## Features

- 4-20 mA, 0-20 mA, 0-10V or -10V to +10V transmitter output, 16 bits, isolated
- RS232 or RS485 serial data output, Modbus or Laurel ASCII protocol, isolated
- Dual 120 mA solid state relays for alarm or control, isolated
- Transmits single event time or accumulated time of all events
- Timing from 0.2  $\mu$ s to 999,999 hrs
- Inputs from NPN or PNP proximity switches, contact closures, digital logic, or magnetic pickups down to 12 mV.
- 4-20 mA or 0-10V transmitter output, jumper selectable, isolated
- Analog output resolution 0.0015% of span (16 bits), accuracy  $\pm$ 0.02% of span
- 5V, 10V or 24V dc transducer excitation output, isolated
- Universal 85-264 Vac / 90-300 Vdc or 10-48 Vdc / 12-32 Vac power



## Description

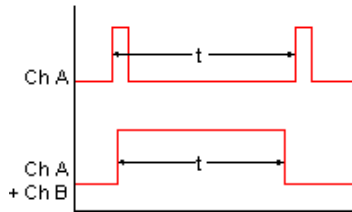

The Laureate stopwatch transmitter outputs isolated analog and serial data signals whose values track the time of single events which produce start and stop pulses, or the accumulated time of multiple events. It can also time the width of a single pulse. The highest resolution is 0.2  $\mu$ s, making the transmitter ideal for fast events. The longest timing interval is 999,999 hrs. For long events, the analog output is updated continuously during timing. There are two primary timing modes:

- **A-A Stopwatch Mode:** Time is measured between a start pulse and a stop pulse, both on Channel A, from either the positive or negative edges.
- **A-B Stopwatch Mode:** Time is measured between a start pulse on Channel A (positive or negative edge) and a stop pulse on Channel B (positive or negative edge). This mode allows inputs from different sources. In addition, the A and B inputs can be tied together to start the stopwatch with one polarity and stop it with the other polarity.

**Event time** (Item #1) is measured by counting 5.5 MHz clock pulses from a calibrated quartz crystal. The stopwatch output is updated during timing at a rate controlled by a gate time, up to 25/sec. Time is reset to zero when the next start pulse occurs.

**Accumulated time** (Item #2) from multiple events up to 999,999 hours is also tracked and can be transmitted.

The dual-channel signal conditioner used for pulse detection accepts inputs from proximity switches with PNP or NPN output, TTL or CMOS logic, magnetic pickups, contact closures, and AC signals from 12 mV to 250 Vac. Jumper selections provide optimum operation for different sensor types and noise conditions.

### Standard features of Laureate transmitters include:

- **4-20 mA, 0-10V or -10V to +10V analog transmitter output,** isolated, jumper-selectable and user scalable. All selections provide 16-bit (0.0015%) resolution of output span and 0.02% output accuracy of a reading from -99,999 to +99,999 counts that is also transmitted digitally. Output isolation from signal and power grounds eliminates potential ground loops.
- **Serial communications output,** isolated. User selectable RS232 or RS485, half or full duplex. Three protocols are user selectable: Modbus RTU, Modbus ASCII, or Laurel ASCII. Modbus operation is fully compliant with Modbus Over Serial Line Specification V1.0 (2002). The Laurel ASCII protocol allows up to 31 Laureate devices to be addressed on the same RS485 data line. It is simpler than the Modbus protocol and is recommended when all devices are Laureates.
- **Dual solid state relays,** isolated. Available for local alarm or control. Rated 120 mA at 130 Vac or 170 Vdc.
- **Universal 85-264 Vac power.** Low-voltage 10-48 Vdc or 12-32 Vac power is optional.

**Easy Transmitter programming** is via Laurel's Instrument Setup Software, which runs on a PC under MS Windows. This software can be downloaded from our website at no charge. The required transmitter-to-PC interface cable is available from Laurel (P/N CBL04).

## Specifications

<b>Pulse Input</b>	
Signal Input	AC, pulses from NPN, PNP transistors, contact closures, magnetic pickups.
Signal Ground	Common ground for channels A & B
Minimum Signal	Nine ranges from (-12 to +12 mV) to (+1.25 to +2.1V).
Maximum Signal	250 Vac
Maximum Frequency	1 MHz, 30 kHz, 250 Hz (selectable).
Contact Debounce	0, 3, 50 ms (selectable).
Time Base Accuracy	Quartz crystal calibrated to $\pm 2$ ppm.
Span Tempco	$\pm 1$ ppm/ $^{\circ}$ C (typ)
Long-term Drift	$\pm 5$ ppm/year
<b>Analog Output (standard)</b>	
Output Levels	4-20 mA, 0-20 mA, 0-10 Vdc, -10 to +10Vdc (user selectable)
Compliance, 4-20 mA	10V (0-500 $\Omega$ load)
Compliance, 0-10V	2 mA (5 k $\Omega$ load)
Output Resolution	16 bits (65,536 steps)
Output Accuracy	$\pm 0.02\%$ of output span
Output Update Rate	Programmed gate time + 30 ms + 0-2 signal periods
Output Isolation	250V rms working, 2.3 kV rms per 1 minute test
<b>Serial Data Output (standard)</b>	
Signal Types	RS232 or RS485 (half or full duplex)
Data Rates	300, 600, 1200, 2400, 4800, 9600, 19200 baud
Output Isolation	250V rms working, 2.3 kV rms per 1 min test
Serial Protocols	Modbus RTU, Modbus ASCII, Laurel ASCII
Modbus Modes	RTU or ASCII
Modbus Compliance	Modbus over Serial Line Specification V1.0 (2002)
Digital Addressing	247 Modbus addresses. Up to 32 devices on an RS485 line without a repeater
<b>Dual Relay Output (standard)</b>	
Relay Type	Two solid state relays, SPST, normally open, Form A
Load Rating	120 mA at 140 Vac or 180 Vdc
<b>Sensor Excitation Output (standard)</b>	
Output Levels	5V@100 mA, 10V@120 mA, 24V@50 mA (jumper selectable)
Output Isolation	50V from signal ground
<b>Power Input</b>	
Standard Power	85-264 Vac or 90-300 Vdc
Low Power Option	10-48 Vdc or 12-32 Vac
Power Frequency	DC or 47-63 Hz
Power Isolation	250V rms working, 2.3 kV rms per 1 min test
Power Consumption	2W typical, 3W with max excitation output
<b>Mechanical</b>	
Dimensions	129 x 104 x 22.5 mm case
Mounting	35 mm rail per DIN EN 50022
Electrical Connections	Plug-in screw-clamp connectors
<b>Environmental</b>	
Operating Temperature	0 $^{\circ}$ C to 55 $^{\circ}$ C
Storage Temperature	-40 $^{\circ}$ C to 85 $^{\circ}$ C
Relative Humidity	95% at 40 $^{\circ}$ C, non-condensing
Cooling Required	Mount transmitters with ventilation holes at top and bottom. Leave 6 mm (1/4") between transmitters, or force air with a fan.



Absolute  
Gauge  
Technologies™

Presented by: Absolute Gauge Technologies  
sales@absolute-gauge.com; www.absolute-gauge.com  
Toronto: 416 754 3168, Montreal: 514 695 5147, Toll Free: 1 888 754 7008

## Pinout

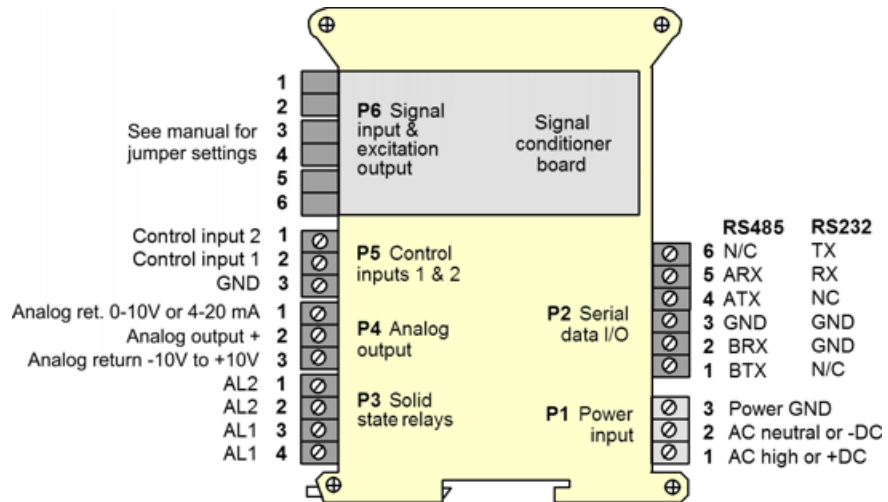

## Mechanical

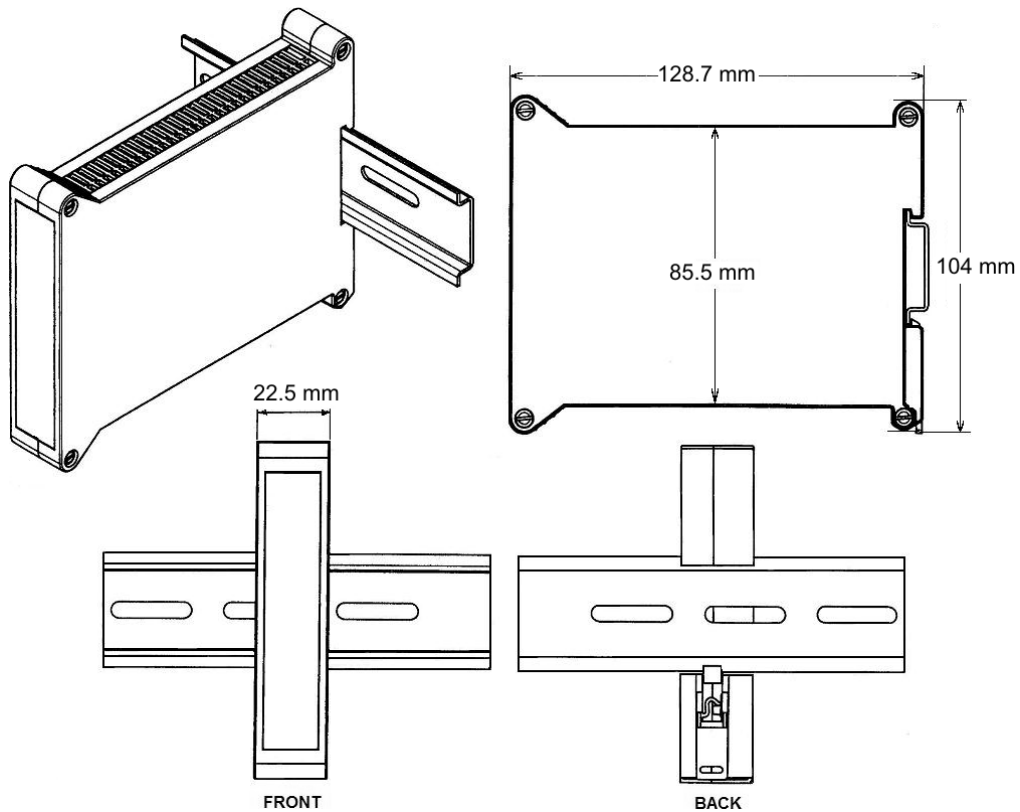

**AGT** Absolute Gauge Technologies™

Presented by: Absolute Gauge Technologies  
 sales@absolute-gauge.com; www.absolute-gauge.com  
 Toronto: 416 754 3168, Montreal: 514 695 5147, Toll Free: 1 888 754 7008

## Application Examples of Laureate Stopwatch Meters or Transmitters

Stopwatch Mode	
	<p>The stopwatch mode is used to time single events between start and stop pulses on the same channel. Duration of a single wave shape can be measured by tying the A and B channels together.</p>
Timing Process Dynamics	
	<p>The start and stop pulses used for timing can be generated by the dual relays in a Laureate panel meter, counter, or transmitter. For instance, the start and stop pulse edges can be created as temperature passes two alarm setpoints, or as temperature cycles in a hysteresis control mode.</p>
Replacing an Oscilloscope with a Laureate Meter or Transmitter	
	<p>An oscilloscope is great for viewing and timing pulses in a lab. However, in fixed installations where digital timing accuracy and control outputs are required, a low-cost Laureate time interval meter or transmitter will be the instrument of choice. Resolution to 0.2 <math>\mu</math>s is feasible.</p>
Instrumenting a Pulsed Laser System	
<p>Some of the many possibilities in instrumenting a pulsed laser system with Laureate dual-channel counters and transmitters: elapsed time, number of pulses, pulse width, pulse separation, duty cycle, and pulse rep rate.</p>	

## Ordering Guide

Create a model a model number in this format: **LT60FR, CBL04**

<b>Transmitter Type</b>	<b>LT</b> Laureate 4-20 mA & RS485 Transmitter
<b>Main Board</b>	<b>6</b> Standard Main Board
<b>Power</b>	<b>0</b> Isolated 85-264 Vac or 90-300 Vdc <b>1</b> Isolated 12-32 Vac or 10-48 Vdc
<b>Input Type</b>	<b>FR</b> Dual-Channel Frequency
<b>Accessories</b>	<b>CBL04</b> RS232 cable, 7ft. Connects RS232 screw terminals of LT transmitter to DB9 port of PC. <b>CBL02</b> USB to RS232 adapter cable. Combination of CBL02 and CBL04 connects transmitter RS232 terminals to PC USB port.

