

NOVOSTRICTIVE Transducer up to 4250 mm touchless - absolute

Series TP1
 with Start-Stop, SSI-,
 or DyMoS interface

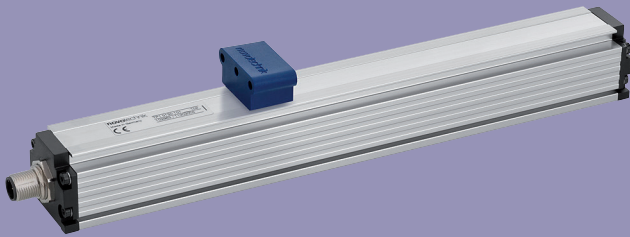

Special features

- absolute transducer in robust profile design
- NOVOSTRICTIVE non-contacting magnetostrictive measurement principle
- non-contact position detection
- wear-free, unlimited mechanical life span
- Start-Stop pulse interface with normed speed of operation 2800 m/s
- Synchronous serial interface
- DyMoS®-interface with data transfer monitoring
- excellent linearity up to 10 µm
- resolution up to 0.001 mm regardless of stroke length
- low temperature coefficient <15 ppm/K
- insensitive to shock and vibration
- cable or connector version available
- protection class IP67 / IP68

TP1 transducers employ the NOVOSTRICTIVE touchless magnetostrictive measuring process for direct, precise, and absolute measurement of linear position, for motion control, positioning and measurement display applications.

The transducers are mechanically very robust and resistant to high shock and vibration. The active sensing element is encased in an aluminum housing rated to IP68. This makes for excellent ingress protection from dust, moisture and oils.

This measurement principle uses position markers (magnets) as mechanical input devices. The position markers are available in free-floating or rail-guided versions.

The pulse interface allows a fully tolerated processing of both edges of the Start/Stop signal and an usage of up to 3 position markers.

Clamps allow easy and flexible transducer mounting, as well as precise adjustment of the installation position.

The TP1 also provides an option for highly-dynamic serial DyMoS®- interface. It offers the advantages of bus-type and conventional interfaces, and also optionally calculates and transmits position marker velocity.

The transducers are insensitive to dust, humidity, or oils.

Additional interfaces - see separate data sheet.

Description	
Housing	aluminium, anodized, metal end flanges
Mounting	adjustable clamps
Position marker	floating position marker, plastic guided position marker, ball coupling
Measurement principle	NOVOSTRICTIVE touchless magnetostrictive
Electrical connections	8-pin round connector, shielded, M12 x 1 8-pin round connector, shielded, IEC130-9 6-pin round connector, shielded, IEC130-9 8-wire PUR / PVC-cable, 8 x 0.25 mm ² , shielded: 1 m, 5 m or 10 m length
Electronic	SMD with ASIC, integrated Connector casing (shield) is connected to the sensor housing. Housing is capacitively decoupled from the electronics

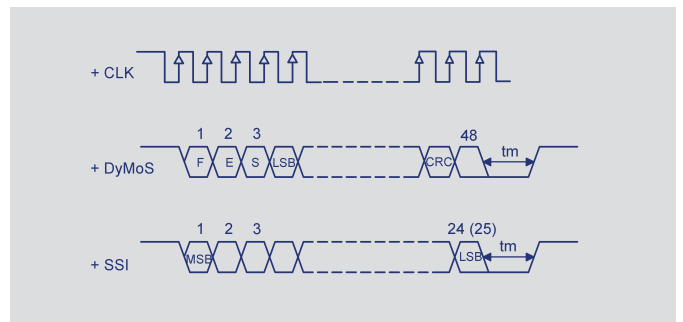
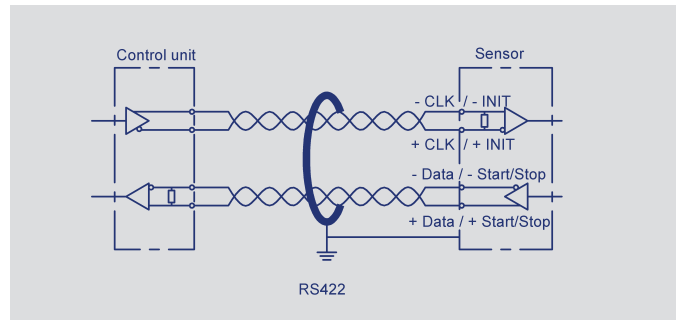
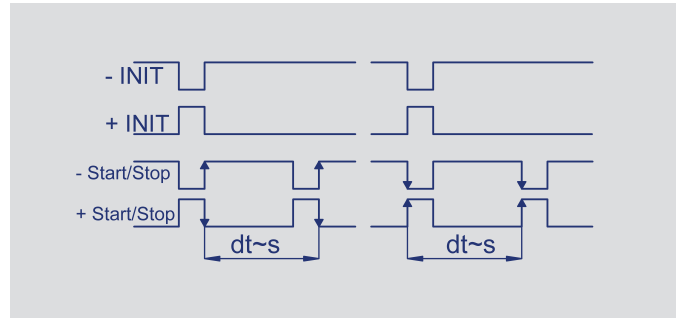
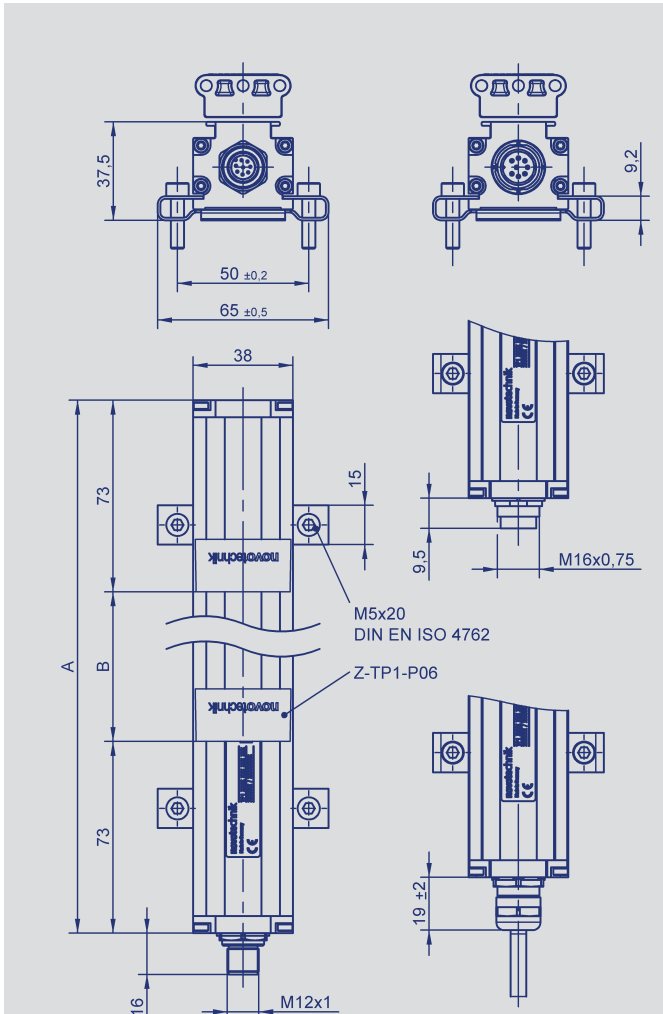

Output connector Code 101, 102	Cable Code 201, 203, 205	Connector with cable EEM33-86, EEM33-87	Start/Stop-Impulse interface	Synchronous-Serial interface	DyMoS®- interface
PIN 1	YE	WH	+ INT	+ Clk	+ Clk
PIN 2	GY	BN	+ Start/Stop	+ Data	+ Data 1
PIN 3	PK	GN	- INT	- Clk	- Clk
PIN 4	RD	YE	do not connect	do not connect	- Data 2
PIN 5	GN	GY	- Start/Stop	- Data	- Data 1
PIN 6	BU	PK	supply GND	supply GND	supply GND
PIN 7	BN	BU	+24 VDC	+24 VDC	+24 VDC
PIN 8	WH	RD	do not connect	do not connect	+ Data 2

Output connector Code 103	SSI interface	Start-Stop- Impulse interface
PIN 1	- Data	- Start/Stop
PIN 2	+ Data	+ Start/Stop
PIN 3	+ Clk	+ INT
PIN 4	- Clk	- INT
PIN 5	+ 24 VDC	+ 24 VDC
PIN 6	supply GND	supply GND

Type designations	TP1- _ _ _ _ - 101 - 11 _ _ _ _ TP1- _ _ _ _ - 101 - 12 _ _ _ _ Start-Stop-Impulse interface	TP1 - _ _ _ _ - 101 - 2 _ _ _ _ Synchronous-Serial interface	TP1 - _ _ _ _ - 101 - 13 _ _ _ _ DyMoS interface	
Electrical Data				
Electrical measuring range (dimension B)	0050 up to 4250	0050 up to 4250	0050 up to 4250	mm
Absolute linearity	$\leq \pm 50 \mu\text{m}$	$\leq \pm 10 \mu\text{m}^{**}$ up to 1000 mm $\leq \pm 25 \mu\text{m}^{**}$ up to 2500 mm $\leq \pm 40 \mu\text{m}^{**}$ up to 4250 mm	$\leq \pm 10 \mu\text{m}^{**}$ up to 1000 mm $\leq \pm 25 \mu\text{m}^{**}$ up to 2500 mm $\leq \pm 40 \mu\text{m}^{**}$ up to 4250 mm	
Tolerance of electrical zero point	± 0.5	± 0.5	± 0.5	mm
Output signal	RS422 Impulse	RS422 absolute 24, 25 or 26 Bit	RS422 absolute 48 bit synchronous-serial	
Resolution	standardized up to 2800 m/s	1 or 5 μm	5 μm	
Reproducibility	≤ 6	≤ 6	≤ 6	μm
Hysteresis	≤ 4	≤ 4	≤ 4	μm
Supply voltage	24 (13...34)	24 (13...34)	24 (13...34)	VDC
Supply voltage ripple	≤ 10	≤ 10	≤ 10	% Vss
Current consumption	≤ 100	≤ 100	≤ 100	mA
Output update rate max. *	0.25 ... 1	16	16	kHz
Temperature coefficient	≤ 15 (min. 0.01 mm/K)	≤ 15 (min. 0.01 mm/K)	≤ 15 (min. 0.01 mm/K)	ppm/K
Overvoltage protection	40 (permanent)	40 (permanent)	40 (permanent)	VDC
Polarity protection	up to Umax	up to Umax	up to Umax.	VDC
Signal output protection	7 (permanent)	7 (permanent)	7 (permanent)	VDC
Insulation resistance (500 VDC)	≥ 10	≥ 10	≥ 10	M Ω
Mechanical Data				
Dimensions	see drawing	see drawing	see drawing	
Body length (dimension A)	dimension B + 146	dimension B + 146	dimension B + 146	± 2 mm
Standard measuring range (dimension B)	50, 75, 100, 125, 150, 175, 200, 225, 250, 275, 300, 325, 350, 375, 400, 425, 450, 475, 500, 550, 600, 650, 700, 750, 800, 850, 900, 950, 1000, 1100, 1200, 1300, 1400, 1500, 1600, 1700, 1800, 1900, 2000, 2250, 2500, 2750, 3000, 3250, 3500, 3750, 4000, 4250 Other lengths on request.			mm
Environmental Data				
Operating temperature range	-40...+85	-40...+85	-40...+85	$^{\circ}\text{C}$
Storage temperature range	-40...+105	-40...+105	-40...+105	$^{\circ}\text{C}$
Operating humidity range	0...95 (no condensation)	0...95 (no condensation)	0...95 (no condensation)	% RH
Life	mechanically unlimited (with floating position marker)	mechanically unlimited (with floating position marker)	mechanically unlimited (with floating position marker)	
MTTF (ISO 13849-1, parts count method, w/o load)	27	27	27	years
Functional Safety	When using our products in safety-related systems, please contact us			
Shock per DIN IEC68T2-27	100 (11 ms) (single hit)	100 (11 ms) (single hit)	100 (11 ms) (single hit)	g
Vibration per DIN IEC 68T2-6 20	20 (5...2000 Hz, Amax=0,75 mm)	20 (5...2000 Hz, Amax=0,75 mm)	20 (5...2000 Hz, Amax=0,75 mm)	g
Protection class per DIN EN 60529	IP67 with fastened connector IP68 with cable connection	IP67 with fastened connector IP68 with cable connection	IP67 with fastened connector IP68 with cable connection	
Max. traverse speed with valid output signal	10	10	10	ms^{-1}
Max. traverse acceleration with valid output signal	200	200	200	ms^{-2}
CE-Conformity				
Emission	RF noise field strength EN 55011, class B ESD EN 61000-4-2 Radiated immunity EN 61000-4-3 Burst EN 61000-4-4 Conducted disturbances induced by RF fields EN 61000-4-6			

*) Data are extrapolated, internal update rate depending on length.

**) Measured with 1 micron resolution. With a higher resolution, the permissible linearity error is increased by the resolution.

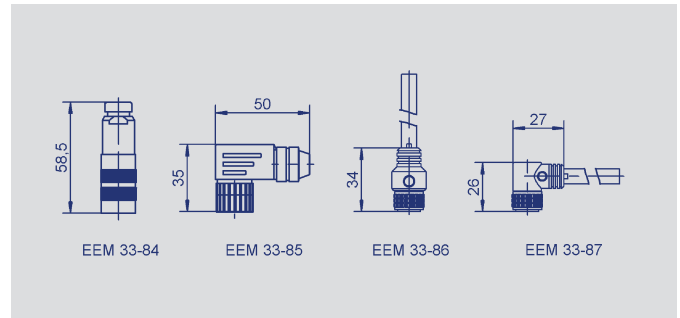
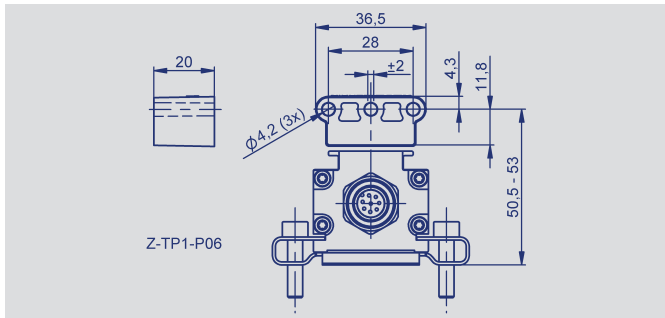

Ordering specifications	Mechanical version 101: Profile design
<p>Preferred types printed in bold</p>	<p>Electrical interface 1: Other digital interface 2: Synchronous-Serial interface</p> <p>Output signal other digital interface 1 _ _ 1: Impulse interface Start Stop Signal (P) (M) 2: Impulse interface measuring time / pulse width 3: DyMoS interface 48 bit Synchronous-Serial</p> <p>Output signal Synchronous-Serial interface 2 _ _ 1: SSI 24 bit 2: SSI 25 bit 7: SSI 26 bit (25 = Alarm; 26 = Parity Even)</p> <p>Impulse interface Start Stop Signal 11 _ 4: For 1 up to 3 position marker variable</p> <p>Impulse interface measuring time / pulse width 12 _ 1: Standard</p> <p>DyMoS®-interface 48 bit Synchronous-Serial 13 _ 1: Binary code, resolution 5 µm; (Pos. 1 + Vel.1) 2: Binary code; resolution 5 µm; (Pos. 1 + Pos.2) 3: Binary code; resolution 5 µm; (Pos. 1 + Vel. 1) and (Pos. 2 + Vel. 2) two channel</p> <p>Synchronous-Serial interface 2 _ _ 1: Binary code; resolution 5 µm 2: Gray code; resolution 5 µm 4: Binary code; resolution 1 µm 5: Gray code; resolution 1 µm</p> <p>Electrical connection 101: 8-pin round connector IEC130-9 102: 8-pin round connector M 12x1 103: 6-pin round connector IEC130-9 201: NT standard cable 1 m 203: NT standard cable 3 m 205: NT standard cable 5 m</p>
<p>T P 1 - 0 8 0 0 - 1 0 1 - 2 1 1 - 1 0 2</p> <p>Series</p> <p>Electrical measuring range Standard lengths 0050 up to 4250 mm 0050 up to 0500 mm in 25 mm-steps, 0500 up to 1000 mm in 50 mm-steps, 1000 up to 2000 mm in 100 mm-steps, 2000 up to 4250 mm in 250 mm-steps. Other lengths on request.</p>	

Included in delivery
 Mounting clamps Z46 electr. isolating incl. cylinder screws.

Required accessories
 Floating position marker Z-TP1-P06, Art.No. 005693, Z-TP1-P07, Art.No. 005694. Guided position marker Z-TP1-P08, Art.No. 005695. Other position marker on request.

Recommended accessories
 Straight connector IEC 130-9 8-pin, EEM 33-84, 6-pin, EEM 33-82. Angled connector IEC 130-9 8-pin, EEM 33-85, 6-pin, EEM 33-86. PUR-cable with 8-pin female connector M12 x 1, 8 x 0.25 mm², shielded: 2 m length, EEM 33-86, 5 m length, EEM 33-90, 10 m length, EEM 33-92. PUR-cable with 8-pin female angled connector, M12 x 1, 8 x 0.25 mm², shielded: 2 m length, EEM 33-87, 5 m length, EEM 33-91, 10 m length, EEM 33-93. Actuating rods Z-TP1-S01_... for position marker Z-TP1-P08.

Available on request
 Standard cable 10 m
 Specific connectors
 Other resolutions
 SSI two channel,
 Incremental, analog and
 fieldbus interfaces

Important: Avoid equalizing currents in the cable shield caused by potential differences. Twisted pair cable is recommended.