

# EtherCAT Gateway

The imc CRONOSflex EtherCAT Gateway is a bus coupler that allows a number of imc CRONOSflex amplifier modules to be used within an EtherCAT-based automation or control system. imc amplifier components can thus be used in EtherCAT environments such as Beckhoff TwinCAT or MTS FlexTest, for example, without the need for a complete CRONOS data logger system (with base unit).

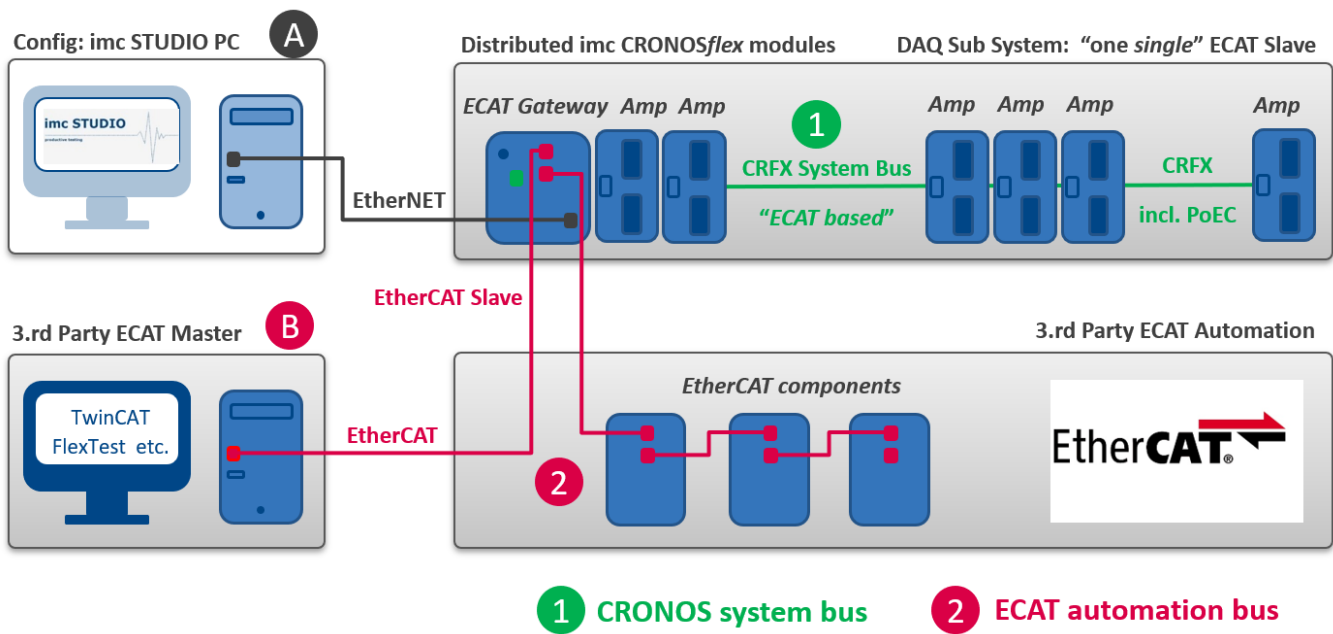

## Application



- A Configuration** Configuration of the imc sub system via imc STUDIO Software (PC via EtherNET)
  - Output ESI and A2L: Information for the EtherCAT Master
  - subsequently: connection no longer required (PC, imc STUDIO): **Auto-Start Mode**
- B DAQ operation** Data acquisition operation via "external" EtherCAT test automation system (e.g. TwinCAT Master) → no redundant parallel data acquisition via imc STUDIO

In connection with the gateway, the CRFX modules act as a data acquisition subsystem in the sense of an EtherCAT slave, without operating in the network of a complete CRONOS data logger. The individual modules are interconnected via the CRFX system bus. This CRONOS system bus is based on the "EtherCAT standard", uses network hardware and is spatially distributable via network cables (Power-over-EtherCAT). The protocol of the CRONOS system bus differs from the "EtherCAT Standard". It is not compatible with EtherCAT 3rd party systems,

i.e. the CRFX modules cannot be operated in such an environment. The ECAT gateway establishes this connection, forming a single EtherCAT slave station.

The ECAT slave subsystem is configured once using imc STUDIO via EtherNET. Afterwards and during active operation this access is no longer necessary.

### Typical applications are:

- Test benches
- Integration of CRFX modules in EtherCAT system environment, such as:
  - TwinCAT automation
  - MTS FlexTest
  - Horiba STARS Engine
  - FEV MORPHEE
  - Instron
- Use of WFT measurement wheels via CRFX/WFT-2 interface module in 3rd party environment

If the target systems implement real-time control, the resulting latencies (signal propagation times) of the system must be taken into account in addition to the sampling rates of the amplifiers (max. 5 kHz) and cycle times of the EtherCAT bus (e.g. 5 kHz or 1 kHz). These are in the order of <2 ms.

### Overview

Standard version		ET version *	
Order Code:	article no.	article no.	remarks
CRFX/ECAT-GATEWAY	11900262	11910015	bus coupler to operate multiple CRFX modules in an EtherCAT 3rd party system

### Software minimum requirements

The operation requires operating software of the following group:  
imc STUDIO 2022 associated with firmware and driver package imc DEVICES 2.15 R1

### Power supply options

- Direct connection (LEMO.EGE.1B.302 power socket)
- Power supply via "Power-Handle" (handle with system supply, imc Click Mechanism)
- Power supply via "Power-Handle" with [UPS functions](#) 

For further details refer to the power options documentation in the manual.

\* ET: Version for an extended temperature range

### Accessories and Plugs

#### Included accessories

Documents		
Certificates and calibration protocols: Detailed information on certificates supplied, the specific contents, underlying standards (e.g. ISO 9001 / ISO 17025) and available media (pdf etc.) can be found on our website, or you can contact us directly.		
Getting started with imc CRONOSflex (one copy per delivery)		
Miscellaneous		
1x Ethernet network cable with latch protection (uncrossed, 2 m)		
AC/DC power adaptor 110-230V AC (with appropriate LEMO plug)		
ACC/AC-ADAP-48-150-1B	48 V DC, 150 W, LEMO.1B.302	13500148
Power plug		
ACC/POWER-PLUG5	DC supply plug LEMO FGG.1B.302, with solder contact, max. 0.34 mm <sup>2</sup>	13500150

#### Optional accessories

Supply module in left handle ("Power-Handle")		
CRFX/HANDLE-POWER-L	handle with system power supply 50 V 100 W, without UPS	11900058
CRFX/HANDLE-NIMH-L	Handle with system power supply 50 V 100 W, UPS with NiMH battery	11900273
CRFX/HANDLE-LI-IO-L	handle with system power supply 50 V 100 W, USV with Li-Ion battery	11900010
Passive handle		
CRFX/HANDLE-L	standard unpowered left handle	11900008
CRFX/HANDLE-R	standard unpowered right handle	11900007
Mounting brackets for fixed installations		
CRFX/BRACKET-90	mounting bracket 90°	11900068
CRFX/BRACKET-180	mounting bracket 180°	11900069
CRFX/BRACKET-BACK	rear panel mounting element	11900070
CRFX/BRACKET-CON	assembly element for two modules	11900071
CRFX/RACK	19" RACK for imc CRONOSflex modules	11900066
CRFX/BRACKET-RACK	mounting element in the RACK	11900072

### Configuration via imc STUDIO

The gateway and the connected modules are configured via imc STUDIO. For this purpose, an Ethernet connection between the gateway and the STUDIO PC must be established.

This configuration and also the Ethernet connection is typically required only once. After that the autostart functionality of gateway and amplifiers can be used. The last valid configuration stored in the device is then automatically loaded when the device is switched on and operation is started.

During configuration, the measuring channels must be set to the desired measuring mode, measuring range, etc.

For the filter setting AAF (automatic anti-aliasing) is to be selected and thereby the sampling rate of the channels is to be set exactly to the rate which is used on the EtherCAT bus as bus cycle, typically either 5 kHz or 1 kHz. Exactly then the AAF filter frequency is matched to the internal cycle rate of the data or pv variable corresponding to the bus cycle.

The actual update rate and thus the effectively utilized EtherCAT bus rate is limited to 5 kHz. If the EtherCAT bus cycle should be selected faster, then the internal rate of max. 5 kHz must still be configured at this EtherCAT gateway during channel configuration. With this rate actually new data are delivered at the bus and also the AAF filter must be adjusted to this rate.

Following the configuration, an A2L file must typically be exported. This file is used to configure the EtherCAT master system. After finishing the configuration, an Autostart configuration must be uploaded to the device (Diskstart), see imc STUDIO manual.

#### Key data

- Max. ECAT bus cycle: 5 kHz (200  $\mu$ s), supported bus cycle: 5 kHz, 1 kHz, 500 Hz, 200 Hz, 100 Hz
- Max. number of channels respectively sampling rates:

34 channels @ 5 kHz	(170 kHz sampling rate)
128 channels @ 1 kHz	and lower

## Technical Specs CRFX/ECAT-GATEWAY

Parameter	Value	Remarks
Max. ECAT bus cycle	5 kHz (200 $\mu$ s)	
Supported bus cycles	5 kHz, 1 kHz, 500 Hz, 100 Hz	
Typical channel configuration of the CRFX modules	sampling rate= ECAT bus cycle, AAF	however maximum 5 kHz only one global sampling rate is allowed
Max. sampling rate	34 channels up to 5 kHz 128 channels up to 1 kHz	170 kHz total sampling rate
<b>Terminal connections</b>		
PC / network	RJ45	max. 100 m cable with 100 MBit (according to IEEE 802.3)
Ethernet TCP/IP	100 MBit	
System bus for <i>flex</i> modules (EtherCAT) "CRFX MODULE"	RJ45 alternatively: module connector	max. 100 m cable between 2 modules warning: here is <a href="#">PoEC power</a>  available
ECAT Slave Interface	2x RJ45 (IN and OUT)	
Sync	BNC	IRIG-B (isolated, TTL) typically not necessary
Power supply	type LEMO.1B (2-pin)	compatible with LEMO.EGE.1B.302 multikodiert 2 Nuten kompatibel mit Steckern FGG.1B.302 (Standard) oder FGE.1B.302 (E-kodiert, 48 V)
Remote control terminal	type LEMO.1B (6-pin)	connector LEMO FGG.1B.306
Module connector	2 x 20-pin	direct connection of modules (click) supply and system bus

<b>Power supply</b>		
Parameter	Value	Remarks
Power supply	10 V to 50 V DC	
Power-on threshold (typ.)	10.0 V	min. input voltage required for power-on (open circuit)
Shutdown threshold (typ.)	9.2 V	input voltage at which the automatic deactivation is triggered (data backup protected by internal UPS buffering)
Power consumption	20 W	depending on model and equipment (e.g. fieldbus, HDD)
AC/DC power adaptor	48 V DC, 150 W 110-230 V AC 50-60 Hz	included in delivery
Pass through power	via module connector and onto RJ45 (EtherCAT): PoEC	min. 42 V required for PoEC

Pass through power limits	
Directly connected imc CRONOSflex modules via module connector	3.1 A (max.), equivalent power with chosen DC power input: <ul style="list-style-type: none"> <li>• 149 W at 48 V DC (standard AC/DC power adaptor resp. DC/DC Power Handle)</li> <li>• 37 W at 12 V DC (typ. DC input voltage)</li> </ul>
Power-over EtherCAT (PoEC) for remote imc CRONOSflex modules	350 mA (max., corresp. to IEEE 802.3), equivalent power with DC power input: <ul style="list-style-type: none"> <li>• 17.5 W at 50 V DC (e.g. DC/DC Power Handle)</li> <li>• 16.8 W at 48 V DC (e.g. AC/DC power adaptor)</li> <li>• 14.7 W at 42 V DC (minimum voltage for PoEC)</li> </ul> Note: minimum system power of 42 V DC required for PoEC

Operating conditions		
Parameter	Value	Remarks
Operating environment	dry, non corrosive environment within specified operating temperature range	
Rel. humidity	80% up to 31°C, above 31°C: linear declining to 50%	according IEC 61010-1
Ingress protection rating	IP20	
Pollution degree	2	
Operating temperature (standard)	-10°C to +55°C	without condensation
Operating temperature (extended: "-ET" version)	-40°C to +85°C	condensation temporarily allowed
Shock- and vibration resistance	IEC 61373, IEC 60068-2-27 IEC 60062-2-64 category 1, class A and B MIL-STD-810 Rail Cargo Vibration Exposure U.S. Highway Truck Vibration Exposure	
Extended shock- and vibration resistance	upon request	specific tests or certifications upon request
Dimensions	90 x 118 x 186 mm	W x H x D
Weight	approximately 1.2 kg	