

8B42

2-Wire Transmitter Interface Modules

Description

8B modules are an optimal solution for monitoring real-world process signals and providing high-level signals to a data acquisition system. Each 8B42 module provides power to a current transmitter, then isolates, filters, and amplifies the resulting process current input signal and provides an analog voltage output (Figure 1).

Current to voltage conversion is accomplished internal to the module to ensure high accuracy.

Signal filtering is accomplished with a 3-pole filter optimized for time and frequency response which provides 60dB per decade of normal-mode rejection above 100Hz.

A special input circuit on the 8B42 module provides protection against accidental connection of power-line voltages up to 40VAC. Clamp circuits on the I/O and power terminals protect against harmful transients.

Isolation is provided by transformer coupling to suppress transmission of common mode spikes or surges. The module is powered from +5VDC, ±5%.

The modules are designed for installation in Class I, Division 2 hazardous locations and have a high level of immunity to environmental noise.

► Features

- +12VDC Loop Supply
- Provides Isolation for Non-Isolated 2-Wire Transmitters
- High-Level Voltage Outputs
- 1500Vrms Isolation
- ANSI/IEEE C37.90.1 Transient Protection
- Input Protection to 40VAC Continuous
- 100dB CMR
- 100Hz Bandwidth
- ±0.05% Accuracy
- ±0.02% Linearity
- Low Drift with Ambient Temperature
- C-UL-US Listed
- CE Compliant
- ATEX Compliance Pending
- Mix and Match Module Types on Backpanel

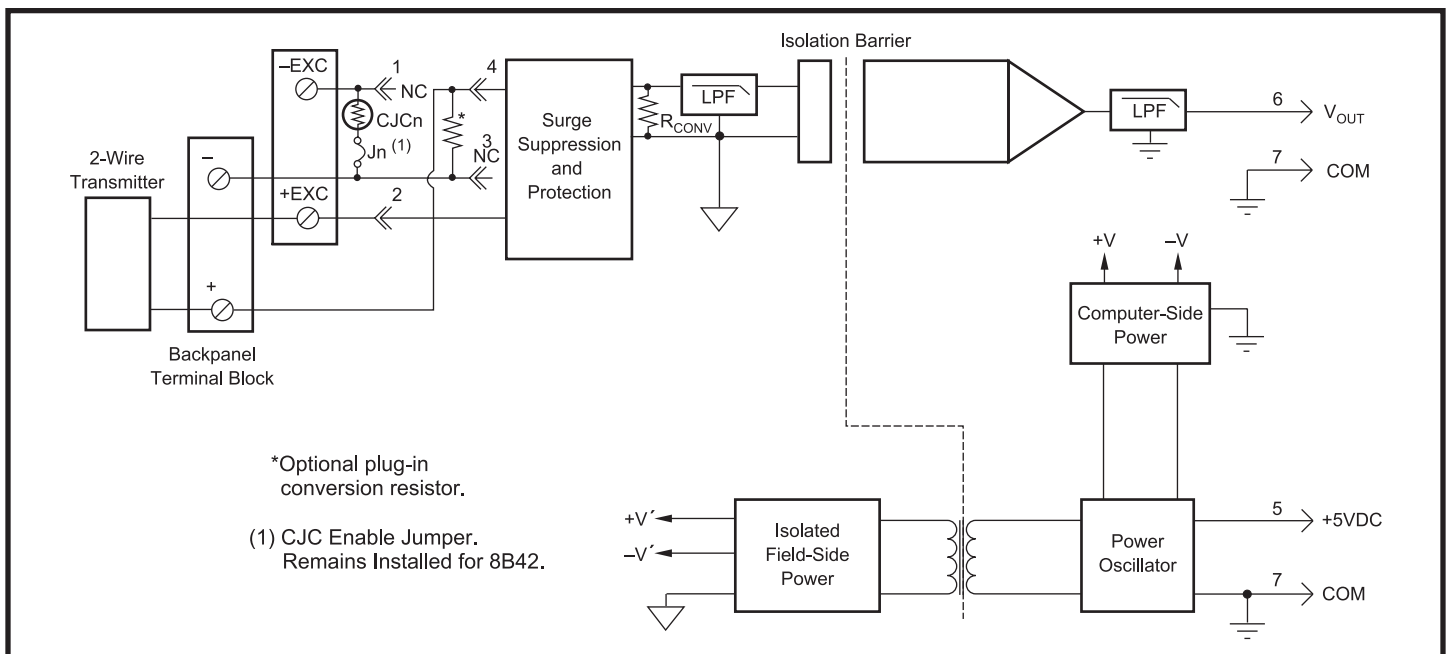

Figure 1: 8B42 Block Diagram

Specifications Typical* at T_A=+25°C and +5VDC power

Module	8B42
Input Range	4mA to 20mA
Input Resistance	
Normal	35Ω
Power Off	35Ω
Input Protection	
Continuous	40VAC
Transient	ANSI/IEEE C37.90.1
Loop Supply Voltage	12VDC
Loop Supply Protection	40VAC
CMV, Input to Output	1500Vrms max
Transient, Input to Output	ANSI/IEEE C37.90.1
CMR (50Hz or 60Hz)	100dB
NMR	60dB per decade above 100Hz
Accuracy ⁽¹⁾	±0.05% Span
Linearity	±0.02% Span
Stability	
Offset	±25ppm/°C
Gain	±75ppm/°C
Noise	
Output, 100kHz	500μVrms
Bandwidth, -3dB	100Hz
Response Time, 90% Span	5ms
Output Range	0V to +5V
Output Protection	Continuous Short to Ground
Transient	ANSI/IEEE C37.90.1
Power Supply Voltage	+5VDC ±5%
Power Supply Current	140mA
Power Supply Sensitivity	±200ppm/%
Mechanical Dimensions (h)(w)(d)	1.11" x 1.65" x 0.40" (28.1mm x 41.9mm x 10.2mm)
Environmental	
Operating Temperature Range	-40°C to +85°C
Storage Temperature Range	-40°C to +85°C
Relative Humidity	0 to 95% Noncondensing
Emissions EN61000-6-4	ISM, Group 1
Radiated, Conducted	Class A
Immunity EN61000-6-2	ISM, Group 1
RF	Performance A ±0.5% Span Error
ESD, EFT	Performance B

NOTES:

*Contact factory or your local Dataforth sales office for maximum values.

(1) Includes linearity, hysteresis and repeatability.

Ordering Information

Model	Input Range	Output Range
8B42-01	4mA to 20mA	0V to +5V
8B42-02	4mA to 20mA	+1V to +5V