

POSIWIRE®

WS12

Analog, SSI or CANopen Output



Sensor for hostile environments

- Protection class IP67
- Measurement ranges 0 ... 100 mm to 0 ... 3000 mm
- Analog output or A/D converted synchronous serial output (SSI) or A/D converted CANopen output

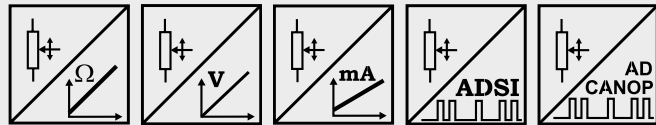

Specifications	Outputs	Potentiometer 1 kΩ Voltage 0 ... 10 V Current 4 ... 20 mA, 2 or 3 wire Voltage or current output, programmable (PMUV/PMUI) A/D converted synchronous serial interface (SSI) A/D converted CANopen bus
	Resolution	Analog: essentially infinite ADSI16: max. 16 bit f.s. ADCANOP: 16 bit f.s.
	Linearity	Up to ±0.05% f.s.
	Sensing device	Precision potentiometer
	Material	Aluminum and stainless steel; cable: stainless steel
	Protection class	IP67 (with mating connector only)
	Connection	Male 8 pin socket M12 (ADCANOP: 5 pin socket)
	Weight	≤1500 mm: 1 kg; ≥2000 mm: 1.5 kg
	EMC, temperature	Refer to output specification

Order code WS12

Model name

Measurement range (in mm)

100 / 125 / 500 / 1000 / 1250 / 1500 / 2000 / 2500 / 3000

Output

R1K = Potentiometer 1 kΩ
 10V = 0 ... 10 V signal conditioner
 420A = 4 ... 20 mA signal conditioner
 420T = 4 ... 20 mA signal conditioner
 PMUV/PMUI = Programmable 0... 10 V or 4 ... 20 mA signal conditioner
 ADSI16 = A/D converted synchronous serial interface 16 bit (12 or 14 bit opt.)
 ADCANOP = A/D converted CANopen bus

Linearity

L10 = ±0.10% option: L05 = ±0.05 % L25 = ±0.25 %

Cable fixing

M4 = M4 cable fixing
 SB0 = Cable clip

Connection

M12 = 8 pin socket M12 (ADCANOP: 5 pin)



Order code connector cable: see page 82/83

Order example: **WS12 - 2500 - 10V - L10 - M4 - M12**

POSIWIRE®

WS12

Analog, SSI or CANopen Output



Cable forces, typical at 20 °C	Range	Max. pull-out force	Min. pull-in force
	[mm]	[N]	[N]
	100	5.2	2.8
	125	4.6	2.5
	500	5.9	2.6
	1000	5.5	2.4
	1250	4.8	2.1
	1500	10.4	6.4
	2000	8.1	5.0
	2500	6.7	4.0
	3000	6.2	3.0

Outline drawing

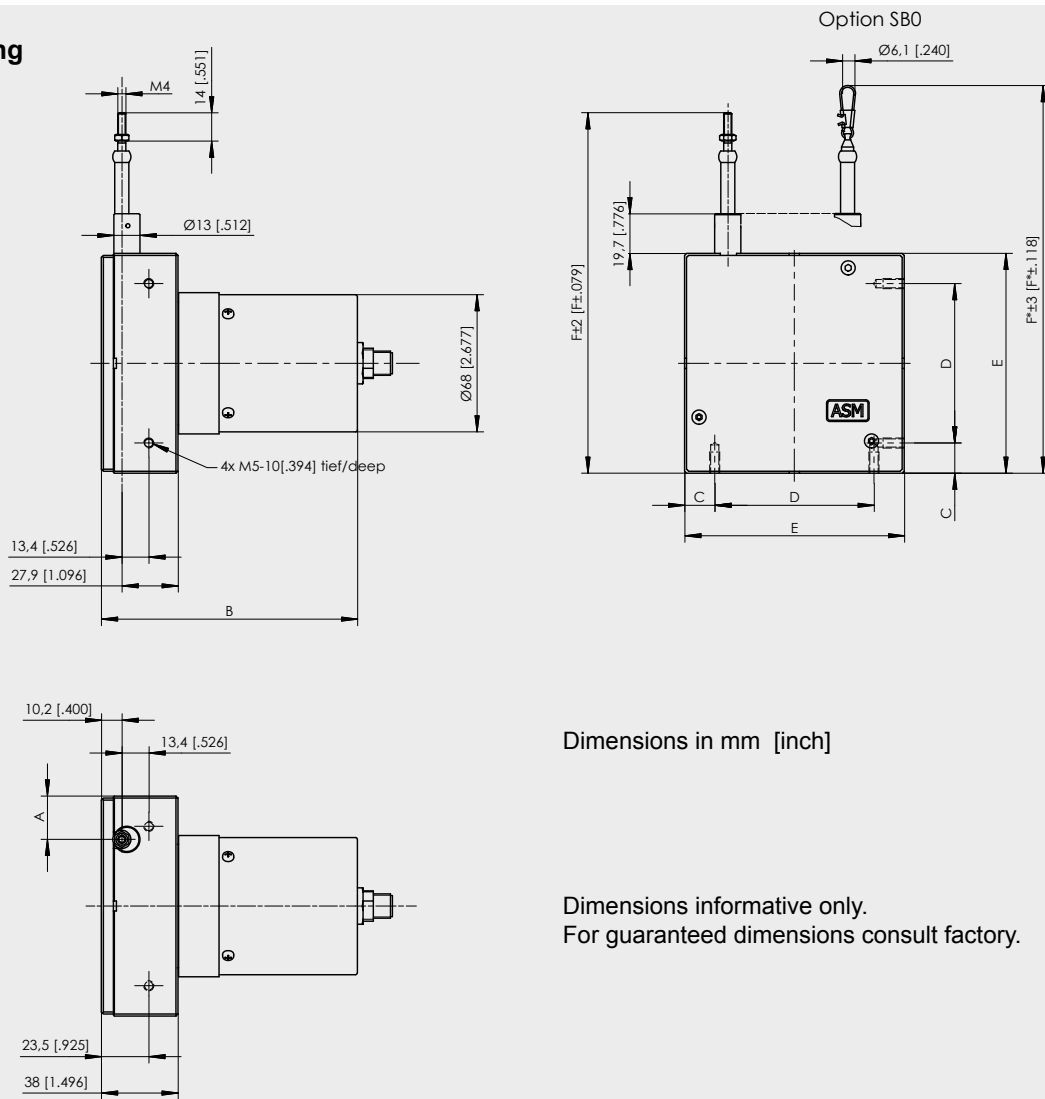

Dimensions in mm [inch]

Dimensions informative only.
For guaranteed dimensions consult factory.

Dimensions in mm	Range	A	B	C	D	E	F	F*
	100; 500; 1000	18.3	112	14	43	71	141	154
125; 1250	14.5	112	14	43	71	141	154	
1500	10.7	127	14	43	71	141	154	
2000	21.5	127	15	79	109	179	192	
2500	13.3	127	15	79	109	179	192	
3000	9.2	127	15	79	109	179	192	

POSIWIRE®
WS12
Incremental Encoder Output



Sensor for hostile environments

- Protection class IP67
- Measurement ranges 0 ... 1250 mm to 0 ... 3000 mm
- Incremental encoder output

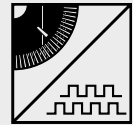

Specifications	Outputs	Incremental encoder output for reliable data transmission. The output is compatible with TTL and HTL.
	Resolution	5 or 10 pulses per mm (1/20 mm or 1/40 mm with external edge counting mode)
	Linearity	±0.05% f.s.
	Sensing device	Incremental encoder
	Material	Aluminum, stainless steel and plastic; cable: stainless steel
	Protection class	IP67
	Connection	Male 8 pin socket M12
	Weight	≤1500 mm: approx. 1 kg; ≥2000 mm: approx. 1.5 kg
EMC, temperature	Refer to output specification	

Order code WS12

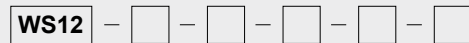

Model name

Measurement range (in mm)

1250 / 1500 / 2000 / 2500 / 3000

Pulses per mm

10 = 10 pulses per mm (1250, 1500 mm)

5 = 5 pulses per mm (2000, 2500, 3000 mm)

Other numbers of pulses on request

Output

PP530 = Incremental output 5 ... 30 V

IE41LI = Incremental encoder TTL compatible

IE41HI = Incremental encoder HTL compatible

Cable fixing

M4 = M4 cable fixing

SB0 = Cable clip

Connection

M12 = 8 pin socket M12

Order code connector cable: see page 82/83

Order example: WS12 - 2500 - 5 - PP530 - M4 - M12

POSIWIRE® WS12 Incremental Encoder Output



Cable forces, typical at 20 °C	Range	Max. pull-out force	Min. pull-in force
	[mm]	[N]	[N]
	1250	6.6	2.7
	1500	10.6	6.5
	2000	5.7	4.1
	2500	5.7	4.1
	3000	5.8	4.0

Outline drawing

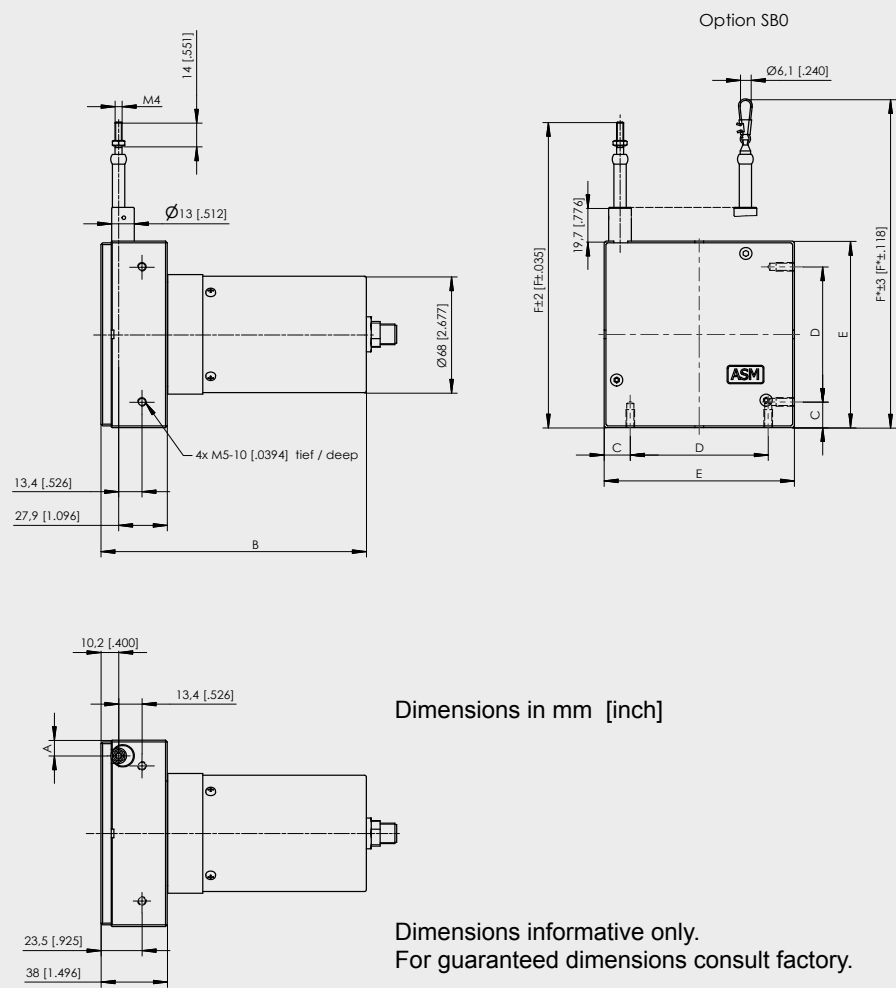

Dimensions in mm	Range	A	B	C	D	E	F	F*
	1250	18.3	137	14	43	71	141	154
1500	10.7	152	14	43	71	141	154	
2000	9.2	152	15	79	109	179	192	
2500	9.2	152	15	79	109	179	192	
3000	9.2	152	15	79	109	179	192	

POSIWIRE® R1K and 10V Analog Output



Voltage divider R1K Potentiometer 	Excitation voltage	32 V DC max. at 1 kΩ (max. power 1 W)
	Potentiometer impedance	1 kΩ ±10 %
	Thermal coefficient	±25 x 10 ⁻⁶ / °C f.s.
	Sensitivity	Depends on the measuring range, individual sensitivity of the sensor is specified on the label
	Voltage divider utilization range	Approx. 3 % ... 97 %
	Operating temperature	-20 ... +85 °C

Output signals

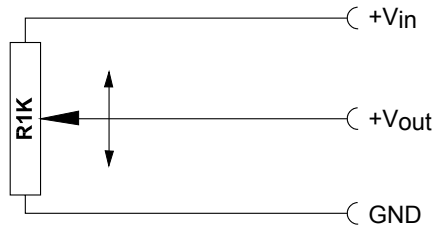

Note: The Potentiometer must be connected as a voltage divider. The input impedance of the following processing circuit should be 10 MΩ min.

Signal conditioner 10V and 10V5 Voltage output 	Excitation voltage	18 ... 27 V DC non stabilized
	Excitation current	20 mA max.
	Output voltage	10V: 0 ... 10 V DC; 10V5: 0.5 ... 10 V DC
	Output current	2 mA max.
	Output load	> 5 kΩ
	Stability (temperature)	±50 x 10 ⁻⁶ / °C f.s.
	Protection	Reverse polarity, short circuit
	Output noise	0.5 mV _{RMS}
	Operating temperature	-20 ... +85 °C
	EMC	According EN 61326:2006

Output signals



Signal wiring	Signal name R1K	10V	Cable color	Connector pin no.
	+Vin	Excitation +	White	1
	GND	Excitation GND	Brown	2
	+Vout	Signal +	Green	3
		Signal GND	Yellow	4

Connection

View to sensor connector

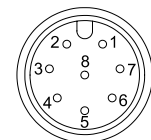

CONN-M12-8F

POSIWIRE® 420A and 420T Analog Output



Signal conditioner 420A Current output (2 wire) 	Excitation voltage	12 ... 27 V DC non stabilized, measured at the sensor terminals
	Excitation current	35 mA max.
	Output current	4 ... 20 mA equivalent for 0 ... 100 % range
	Stability (temperature)	$\pm 100 \times 10^{-6} / ^\circ\text{C}$ f.s.
	Protection	Reversed polarity, short circuit
	Output noise	0.5 mV _{RMS}
	Operating temperature	-20 ... +85 °C
	EMC	According to EN 61326:2006

Output signals

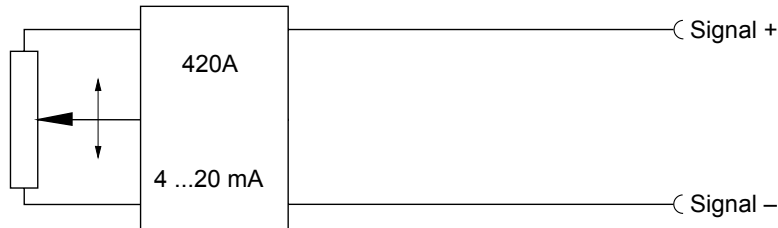

Signal conditioner 420T Current output (3 wire) 	Excitation voltage	18 ... 27 V DC non stabilized
	Excitation current	40 mA max.
	Load resistor	350 Ω max.
	Output current	4 ... 20 mA equivalent for 0 ... 100 % range
	Stability (temperature)	$\pm 50 \times 10^{-6} / ^\circ\text{C}$ f.s.
	Protection	Reverse polarity, short circuit
	Output noise	0.5 mV _{RMS}
	Operating temperature	-20 ... +85 °C
	EMC	According to EN 61326:2006

Output signals



Signal wiring	Signal name		Cable color	Connector pin no.
	420A	420T		
Signal +		Excitation +	White	1
Signal -		Excitation GND	Brown	2
		Signal +	Green	3

Connection

View to sensor
connector

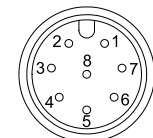

CONN-M12-8F

POSIWIRE® PMUV / PMUI Programmable Analog Output



Signal conditioner PMUV / PMUI Voltage or current output (3 wire)	Excitation voltage	18 ... 27 V DC
	Excitation current	50 mA max.
	Voltage output PMUV	0 ... 10 V
	Output current	10 mA max.
	Output load	1 kΩ min.
	Current output PMUI	4 ... 20 mA (3 wire)
	Working resistance	500 Ω max.
	Scaling	
	Activation of offset and gain adjust	Connect with excitation GND (0 V)
	Scalable range	90% max. f.s.
Stability (temperature)	±50 x 10 ⁻⁶ / °C f.s.	
Operating temperature	-20 ... +85 °C	
Protection	Reversed polarity, short circuit	
EMC	According to EN 61326:2006	

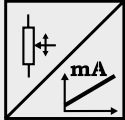
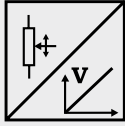

Output signals

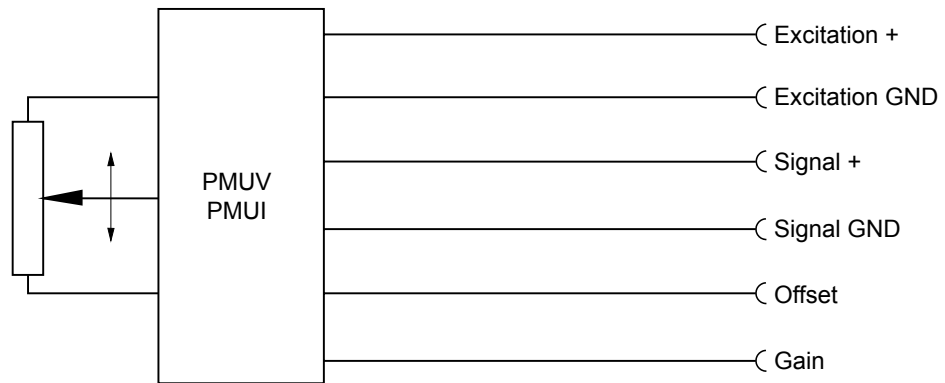

Signal name	Connector pin no.
Excitation +	1
Excitation GND	2
Signal +	3
Signal GND	4
Not used	5
Not used	6
Offset	7
Gain	8

Connection

View to sensor
connector

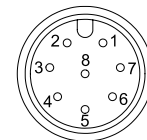

CONN-M12-8F

Signal name	Connector pin no.
Excitation +	1
Excitation GND	2
Not used	3
Not used	4
Signal +	5
Signal GND	6
Offset	7
Gain	8

POSIWIRE® ADCANOP A/D Converted CANopen Bus

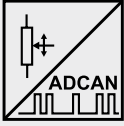

Interface ADCANOP 	Communication profile	CANopen CiA 301 V 4.02, Slave
	Encoder profile	Encoder CiA 406 V 3.2
	Error Control	Node Guarding, Heartbeat, Emergency Message
	Node ID	Adjustable via LSS
	PDO	3 TxPDO, 0 RxPDO, no linking, static mapping
	PDO Modes	Event-/Time triggered, Remote-request, Sync cyclic/acyclic
	SDO	1 server, 0 client
	CAM	2 cams
	Certified	Yes
	Transmission rates	50 kBaud to 1 MBaud, adjustable via LSS
	Nodes	127 max.
	Bus connection	M12 connector, 5 pins
	Integrated bus terminating resistor	No
	Bus, galvanic isolated	No

Specifications	Excitation voltage	8 ... 36 V DC
	Excitation current	Typ. 15/30 mA for 24/12 V, max. 100 mA
	Resolution	16 bit f.s.
	Measuring rate	1 kHz (asynchronous)
	Stability (temperature)	$\pm 50 \times 10^{-6}$ / °C f.s.
	Repeatability	1 LSB
	Operating temperature	-20 ... +85 °C
	Protection	Reverse polarity, short circuit
	Dielectric strength	1 kV (V AC, 50 Hz, 1 min.)
	Environment - EMC Automation	EN 61326:2006

Signal diagram

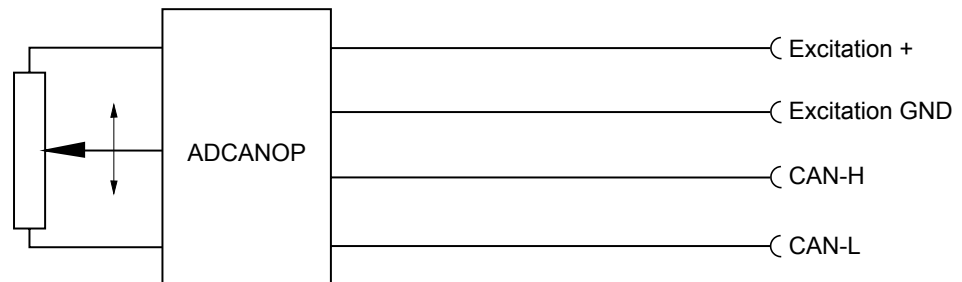

View to sensor connector

Signal wiring / connection	Signal name	Connector pin no.
	Shield	1
	Excitation +	2
	GND	3
	CAN-H	4
	CAN-L	5

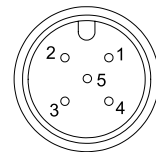

POSIWIRE® PP530 Incremental Output



Signal conditioner PP530 Incremental



Excitation voltage	5 ... 30 V DC
Excitation current	25 mA typ. (w/o load), 200 mA max.
Output frequency	200 kHz max.
Output	Linedriver, Push-Pull, CMOS, TTL- and HTL-compatible
Output current	30 mA max.
Output voltage	Depends on the excitation voltage (e.g. to obtain TTL signals the excitation voltage must be 5 V). Compatible to EIA RS422/RS485
Saturation voltage high/low	$I_a < 10 \text{ mA}, U_B 5 \text{ V}/24 \text{ V}: < 0.5 \text{ V}$ $I_a < 30 \text{ mA}, U_B 5 \text{ V}/24 \text{ V}: < 1 \text{ V}$
Stability (temperature)	$\pm 20 \times 10^{-6} / ^\circ\text{C}$ f.s. (sensor mechanism)
Operation temperature	-10 ... +70 °C
Storage temperature	-30 ... +80 °C
Transition time positive edge	<200 ns
Transition time negative edge	<200 ns
Protection	Reverse polarity, short circuit
EMC	According to EN 61326:2006

Signal diagram

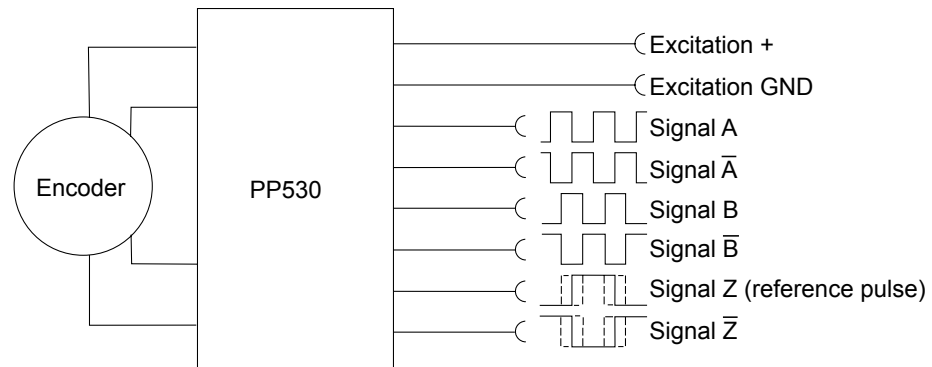

Recommended processing circuit

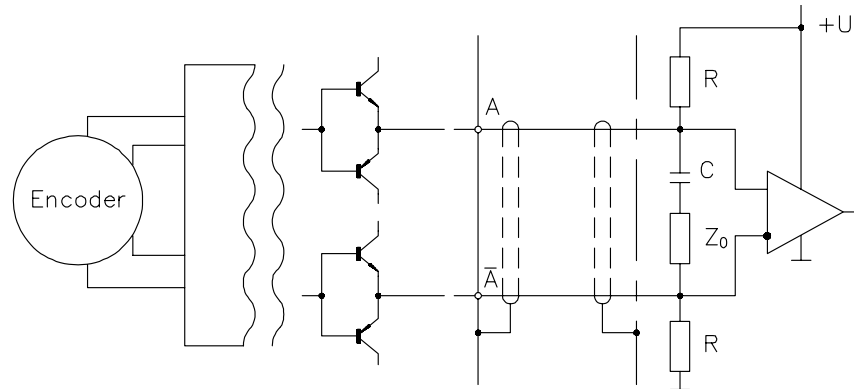

Signal wiring / connection

Output signal name	Connector pin no.
Excitation +	1
Excitation GND (0 V)	2
Signal A	4
Signal A-bar	6
Signal B (A + 90°)	3
Signal B-bar	5
Signal Z (reference pulse)	7
Signal Z-bar	8

View to sensor connector

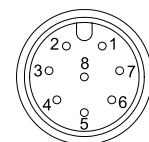

CONN-M12-8F

POSIWIRE® IE41LI and IE41HI Incremental Output



Signal conditioner IE41LI and IE41HI Incremental



	IE41LI	IE41HI
Excitation voltage	5 V DC $\pm 10\%$	10 ... 30 V DC
Excitation current	150 mA max. w/o load	
Output frequency	300 kHz max.	200 kHz max.
Output	RS422	Push-pull antivalent
Output current	± 30 mA max.	30 mA
Output voltage	Depending on the excitation voltage	
Stability (temperature)	$\pm 20 \times 10^{-6}$ / °C f.s. (sensor mechanism)	
Operating temperature	-10 ... +70 °C	
Protection against short circuit	One channel for 1 s	Yes
EMC	According to EN 61326:2006	

Output signals

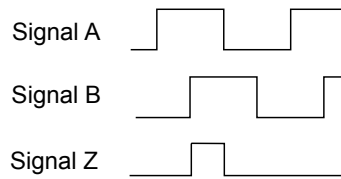

Recommended processing circuit

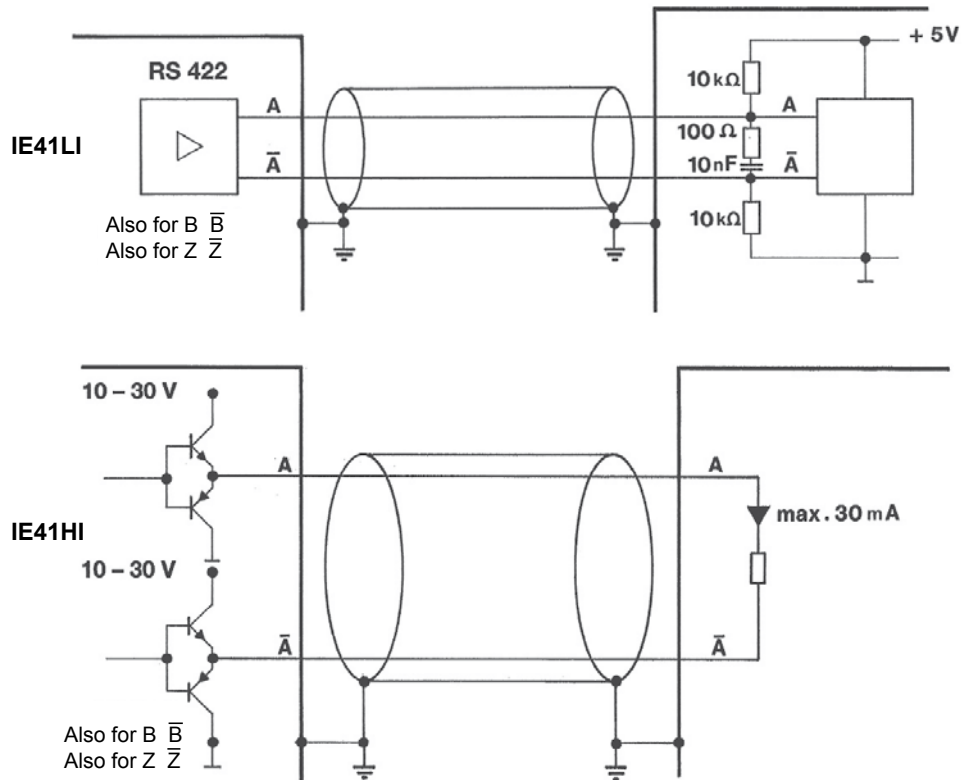

Signal wiring / connection

Signal name	Connector pin no. WS10	Connector pin no. WS12
Excitation +	1	1
Excitation GND (0 V)	2	2
Signal A	4	3
Signal \bar{A}	6	5
Signal B (A + 90°)	3	4
Signal \bar{B}	5	6
Signal Z (reference pulse)	7	7
Signal \bar{Z}	8	8

View to sensor
connector

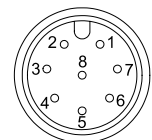

CONN-M12-8F

POSIWIRE®

ADSI16

A/D Converted SSI Output



- Resolution 16 bit, synchronous serial data transmission/SSI
- Optional available with 12 bit (ADSI) or 14 bit (ADSI14) resolution
- No loss of data at power down
- Easy to connect to PLC's with SSI input circuitry

Description

The sensing device of the ADSI is a precision potentiometer. The position information is given by an analog/digital converter output serialized as a data word. Data transmission takes place by means of the signals CLOCK and DATA. The processing unit (PLC, Micro-computer) sends pulse sequences which clock the data transmission with the required transfer rate. With the first falling edge of a pulse sequence the position of the sensor is recorded and stored. The following rising edges control the bit-by-bit A/D conversion, encoding and output of the data word. After a delay time the next new position information will be transmitted.

Signal conditioner ADSI16 A/D converted synchronous serial

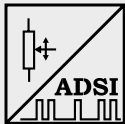

Interface	EIA RS422, RS485, short-circuit proof
Excitation voltage	11 ... 27 V DC
Excitation current	200 mA max.
Clock frequency	70 ... 500 kHz
Code	Gray code, continuous progression
Delay between pulse trains	30 µs min.
Resolution	16 bit (65536 counts) f.s.; optional 12 (ADSI) bit resp. 14 bit (ADSI14)
Stability (temperature)	±50 x 10 ⁻⁶ / °C f.s.
Operating temperature	-20 ... +85 °C
EMC	According to EN 61326:2006

Data format (train of 26 pulses)

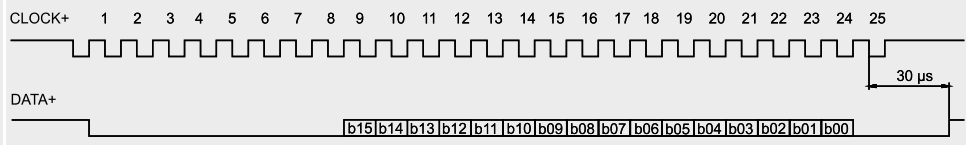

Recommended processing circuit

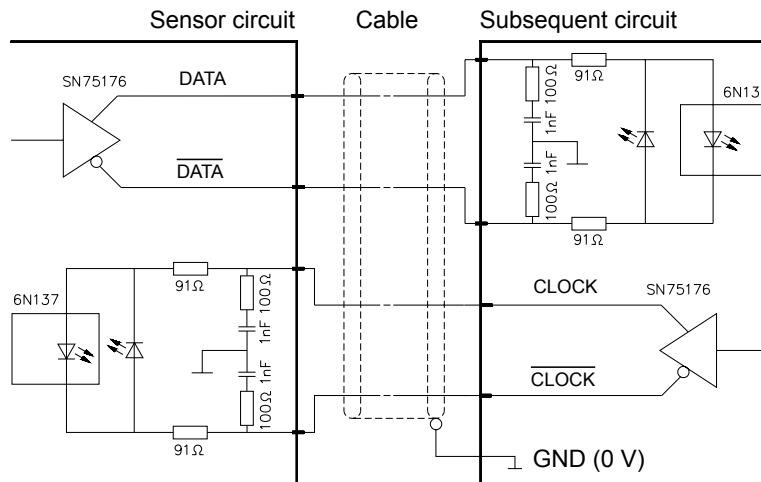

Transmission rate

Cable length	Baud rate
< 50 m	< 300 kHz
< 100 m	< 100 kHz

Note:

Extension of the cable length will reduce the maximum transmission rate.

Signal wiring

Signal name	Connector pin no.
Excitation +	1
Excitation GND (0 V)	2
CLOCK	3
$\overline{\text{CLOCK}}$	4
DATA	5
$\overline{\text{DATA}}$	6
Shield	not connected

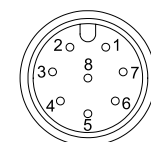

CONN-M12-8F

View to sensor
connector