

Metal Bellows Coupling

MODEL 8695

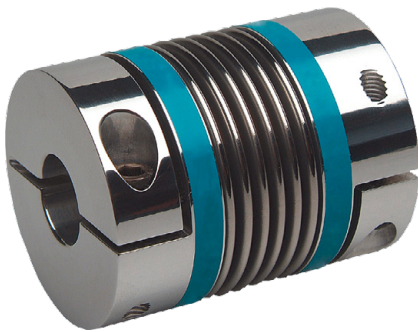

Highlights

- Rated torques from 0 ... ±0,5 N·m to 0 ... ±1000 N·m
- Adaptation to the required shaft diameter
- Accurate transmission of angle and torque
- Suitable for dynamic and static application

Options

- Keyways
- Finely balanced version

Applications

- Simple assembly and safe integration of torque sensors
- Compensation of shaft diameter



Rated torque ≥ 2 N·m



Rated torque 0.5 N·m

Product description

Even after careful alignment of the shaft ends of the sensors with the shaft ends of the plant; slight axial, angular or lateral shift must be anticipated. These interfere with the measurement and can lead to damage on the sensor in the event of high speeds.

The 8695-type steel bellow coupling is fastened, using a clamping hub per torque transmission, to the sensor and plant shafts. The facility-side bore is adapted to the existing shaft diameter, which means that the torque sensor can be mechanically integrated without further adaptations.

A stainless steel bellow transmits the torque between the clamping hubs without backlash. Through its highly elastic but stiff material properties, a lossless transfer of the torque transmission is guaranteed. Axial, angular and lateral shifts caused by assembly and construction are effectively compensated.

Technical Data

8695	-	4500	5002	5010	5030	5060	5150	5200	5500	6001
Nominal torque [N·m] from 0 ...		0.5	2	10	30	60	150	200	500	1000
Mechanical values										
Possible bore diameter D1/D2 (H7)	[mm]	3-8	3-14	5-25	10-32	12-35	18-44	22-47	35-70	45-80
Overall length A	[mm]	23	38	47	65	79	91	101	112	168
Outer diameter B	[mm]	15	25	40.5	56	66	82	90	122	157
Fitting length of hub C	[mm]	6	11	13.5	29	29	33.5	38	42	55
Screws E ISO 4029 / 4762		M3		M4	M6	M8	M10	M12		2 x M20
Distance between centers F	[mm]	not necessary	9	15.5	20	23	28	31	42	55
Distance G	[mm]	2	3.5	5	7.5	10	11	13	15	22.5
Moment of inertia J	[gcm ²]	1.5	27	233	1500	3300	25000	33000	135000	577000
Torsional stiffness Cr	[N·m/ rad]	200	1300	8100	38000	75000	155000	175000	690000	1270000
Max. value axial	[±mm]	0.3	0.2	0.4	0.6		0.5		0.8	
Max. value lateral	[±mm]	0.15		0.2						
Max. value angular	[°]	1.5							1.8	
Environmental conditions										
Operating temperature range		-30 °C ... +120 °C								
Installation										
Tightening torque	[N·m]	0.5	2	4.5	15	40	84	125	145	470
Other										
Overload protection		briefly 150 % of nominal torque								
Material		hub: aluminium; bellows: steel				steel				
Max. speed	[min ⁻¹]	15000			10000	8000	7000	6000	5000	
Weight	[g]	4.5	32	86	300	500	2300	2600	5500	148000

Max. speed in finely balanced design on request

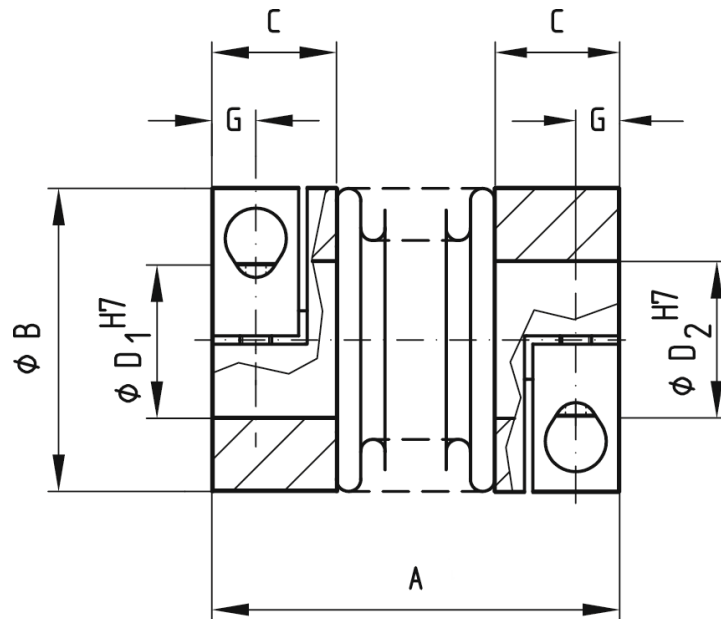
Dimensional drawing **Model 8695**

For detailed dimensions, you can find the CAD data of the sensor on our website www.burster.de

Mounting

Mounting instructions

The couplings have two different attachment systems:

Rated torque 0.5 N·m: The coupling has two radial set screws (ISO 4029). The screws are forming an angle of 120°. The screws are arranged at an angle of 120° to each other and press directly on the shaft. With integrated disassembly nut.

From rated torque 2 N·m: The connection between the shaft and coupling is made with a clamping hub. Only one radially arranged clamping screw (ISO 4762) needs to be tightened to fasten the coupling. First install the coupling on the 'Test Side' of the sensor, second the coupling on the 'Drive Side' of the sensor. Drive shaft and output shaft must be clean and free from burrs. Choose a clearance fit for the fit of the hub. We recommend to choose it similar to our sensor shaft as g6. The shaft surface should have an average roughness in accordance with Rz 6.3 (DIN). For the assembly and disassembly of the couplings a hexagon socket wrench (Allen key) is usually sufficient.

Mounting instructions

Rated torque 0.5 N·m

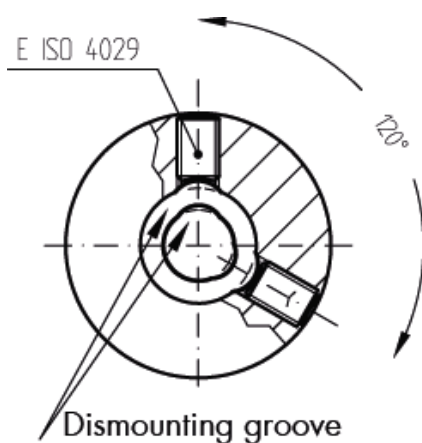

From rated torque 2 N·m

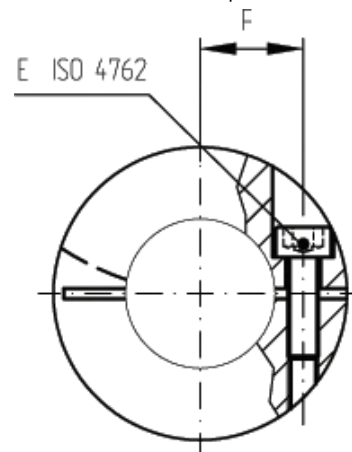

Order Code

Nominal torque		Code			
0 ...	0.5 N·m	4	5	0	0
0 ...	2 N·m	5	0	0	2
0 ...	10 N·m	5	0	1	0
0 ...	30 N·m	5	0	3	0
0 ...	60 N·m	5	0	6	0
0 ...	150 N·m	5	1	5	0
0 ...	200 N·m	5	2	0	0
0 ...	500 N·m	5	5	0	0
0 ...	1000 N·m	6	0	0	1

8	6	9	5	-					-	V					
■ Bore sensor-side D1, specify two digits in mm															
■ Bore facility-side diameter D2, specify two digits in mm															
■ Without keyway														0	
■ With keyway acc. DIN 6885														1	
■ Finely balanced design														5	

4139-008695EN-5699-0911530



Presented by: Absolute Gauge Technologies
 sales@absolutegauge.com; www.absolutegauge.com,
 Toronto: 416 754 3168, Montreal: 514 695 5147, Toll Free: 1 888 754 7008