

MARK	DATE	REVISION	CHA
△			
△			
△			

Around 10mm back and also 5mm forward from origin when origin searching  
Pay attention when mechanical design

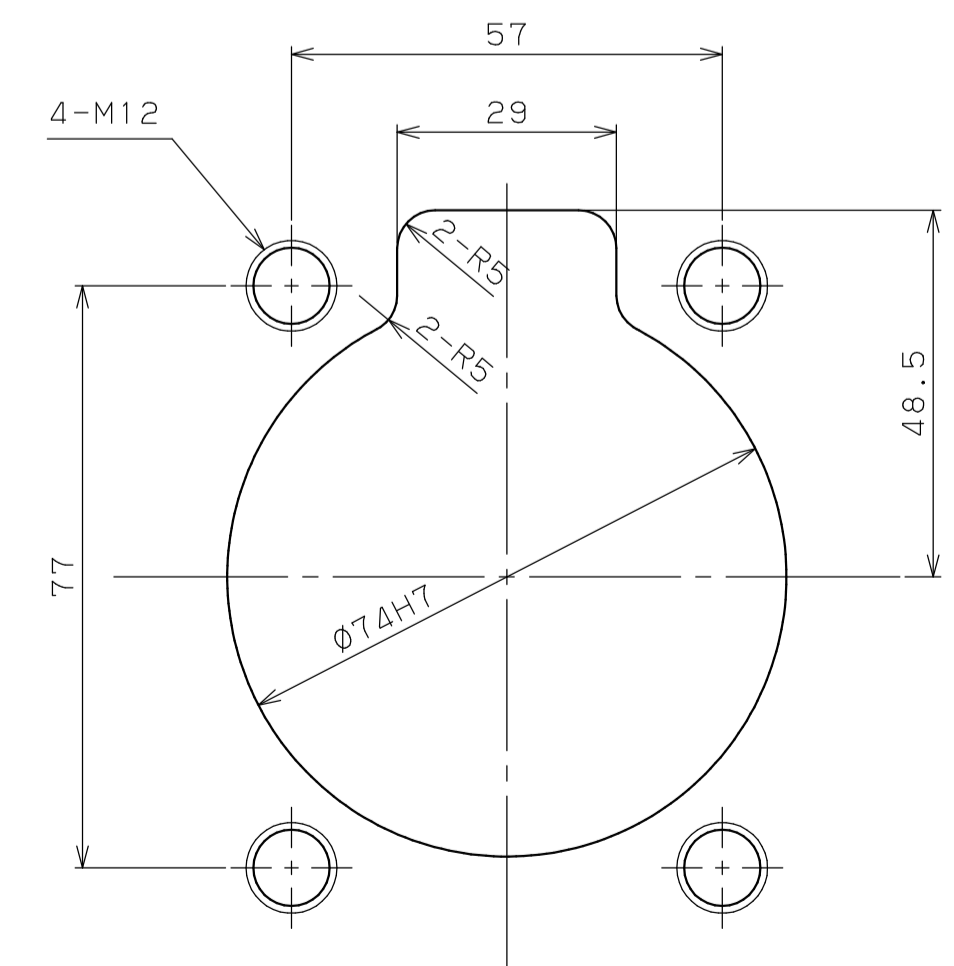
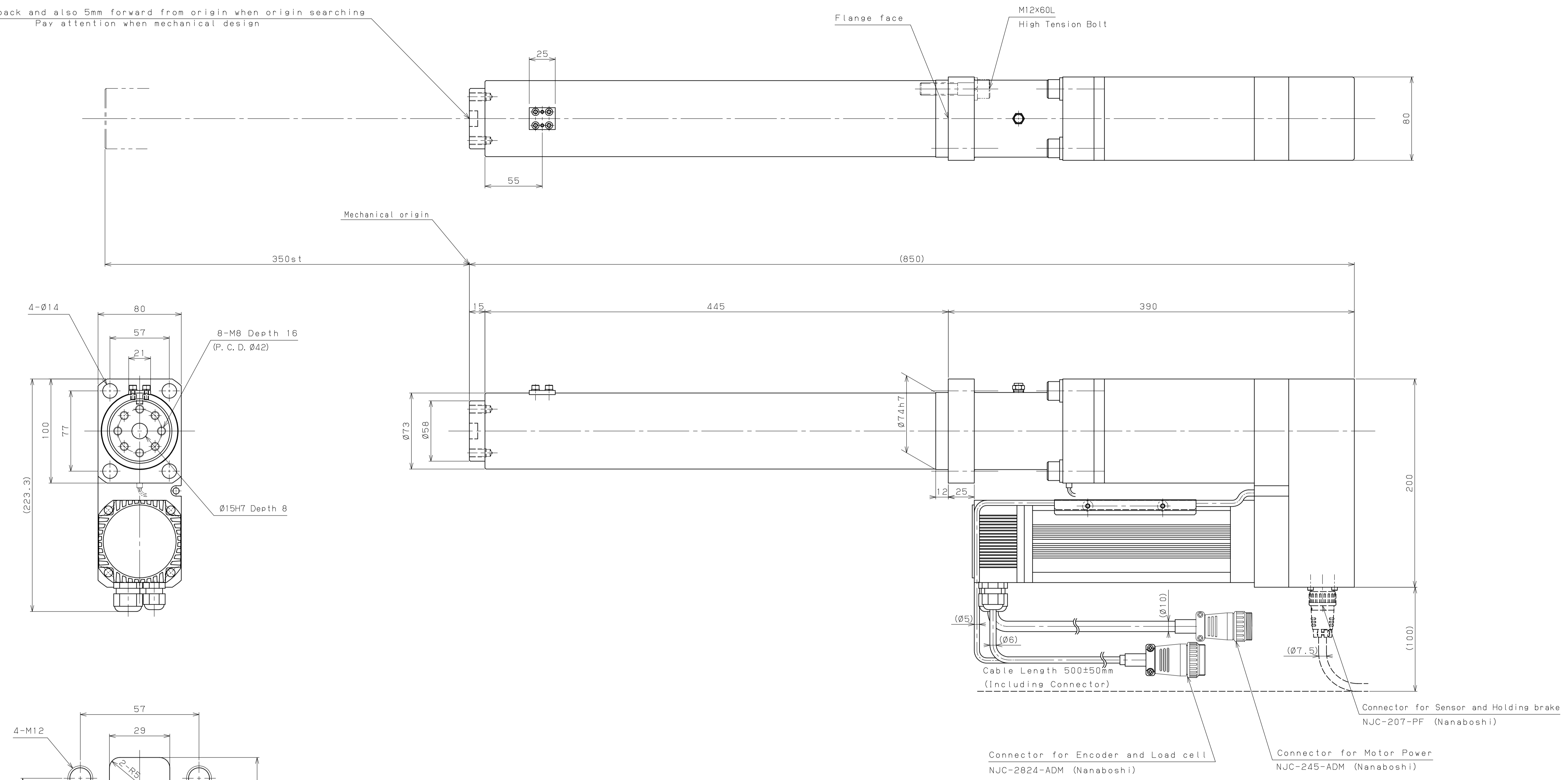

CS20 推奨取付寸法 (2倍図)

- Spec.
1. Normal Force 14kN
  2. Max. Force 20kN
  3. Max. Stroke 350mm
  4. Max. Travel Speed 270mm/sec
  5. Max. Press Speed 30mm/sec

Q'TY	仕様	SEMP. TRIM	納入先	USER
MATERIAL	材質	熱処理	名称	TITLE
FINISH	仕上	硬度	品名	SUB TITLE
WEIGHT	重量	CASE DEPT	品名	SUB TITLE
REMARKS	備考			
長	APPD.	検図	CHK.	設計
				DES.
				製図
				DFT.
				尺規
				SCL.
				日付
				DATE
				09.08.24
				3RD. ANG. PRO.
				三角法
				図番
				DWG. NO.
				CS20-350B ENG