

MARK	DATE	REVISION	CHA
△			
△			
△			

Around 10mm back and also 5mm forward from origin when origin searching
Pay attention when mechanical design

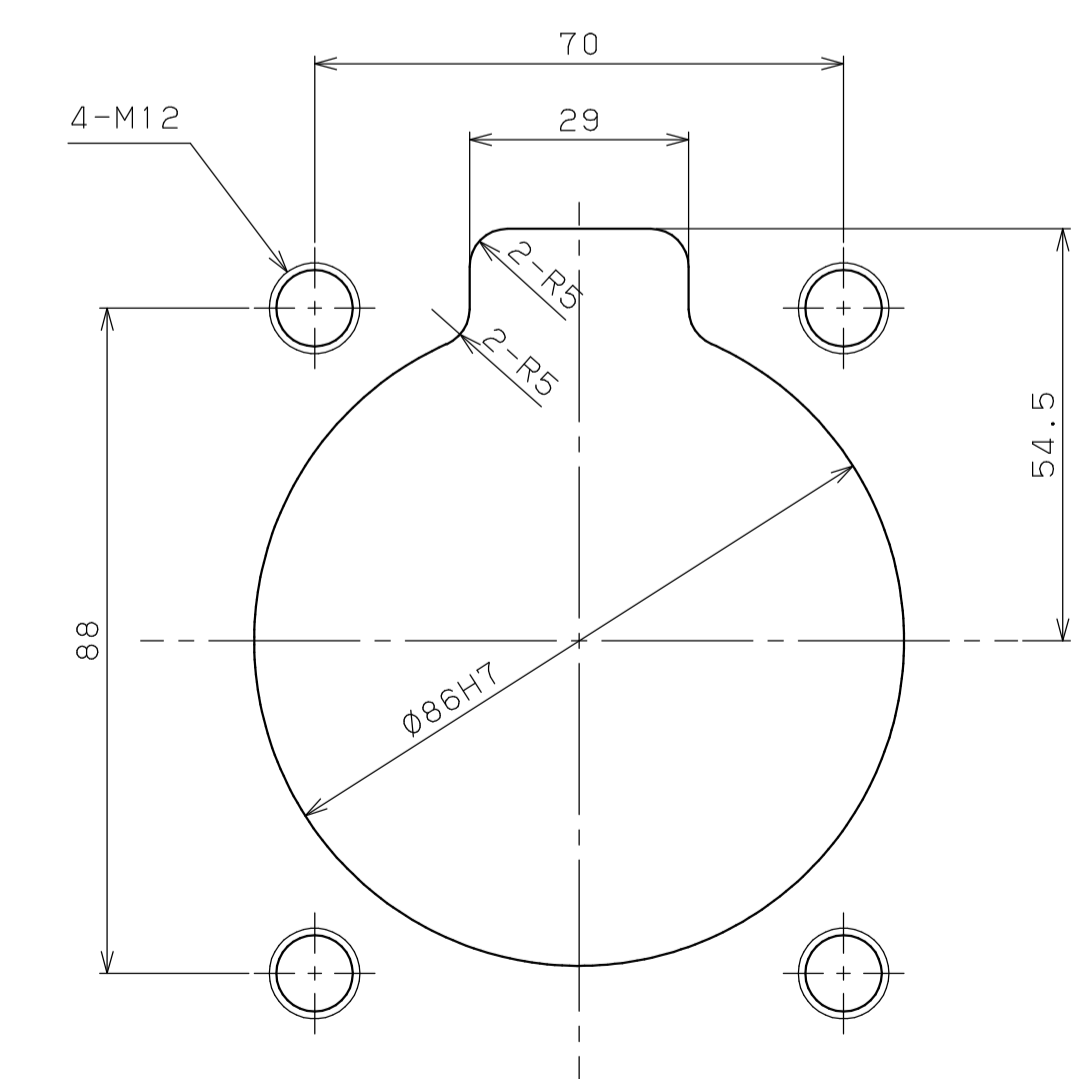
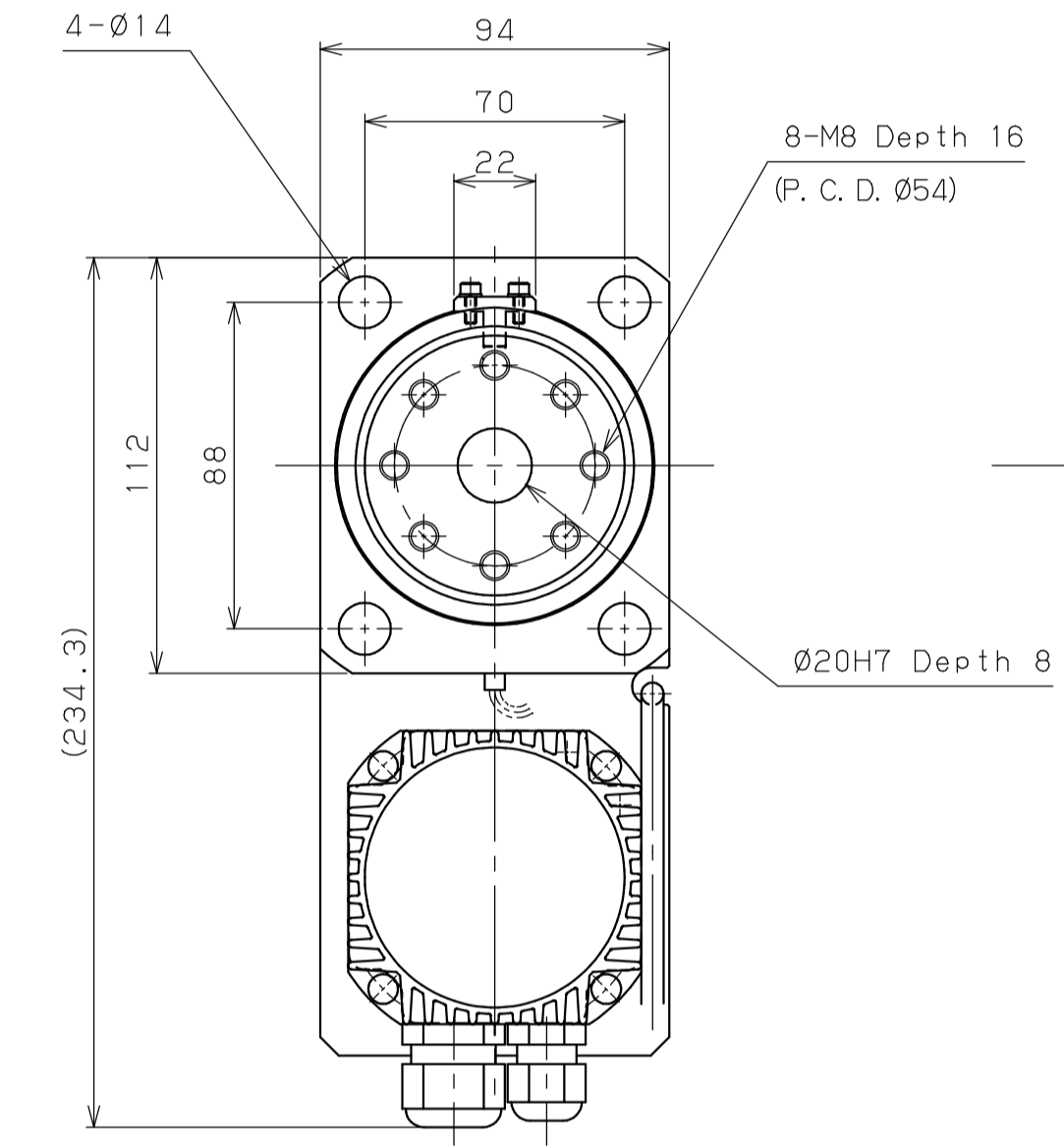
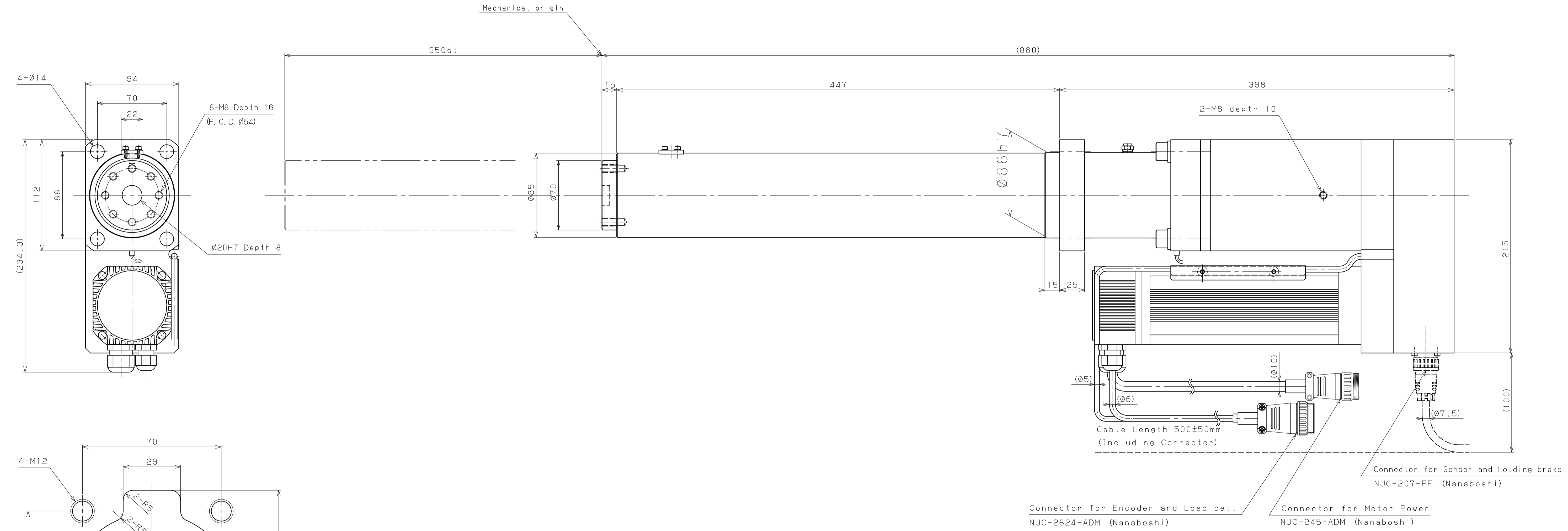
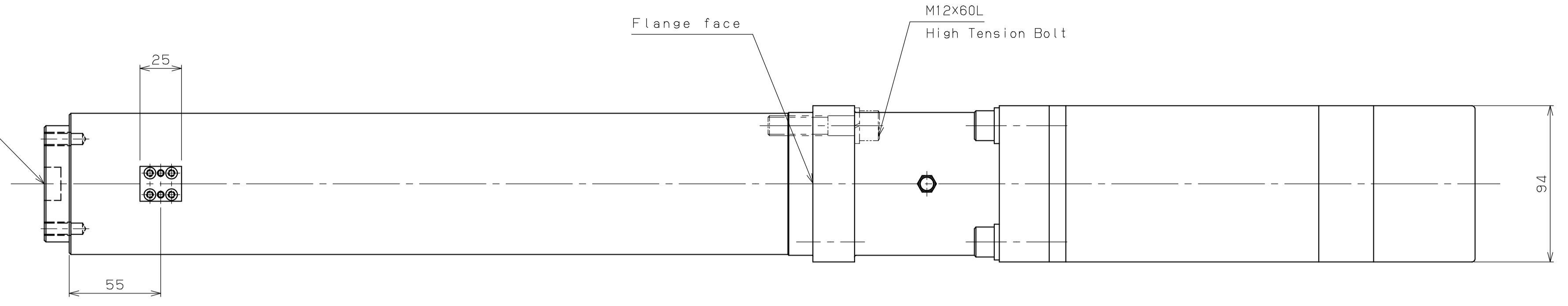

Mounting for CS30 (2:1)

- Spec.
- 1. Normal Force 21kN
 - 2. Max. Force 30kN
 - 3. Max. Stroke 350mm
 - 4. Max. Travel Speed 240mm/sec
 - 5. Max. Press Speed 30mm/sec

Q'TY	数量	SEMP. TITM	定額仕様	納入先	USER
MATERIAL	材質	HEAT. TITM	熱処理	名称	TITLE
FINISH	仕上	HARDNESS	硬度	品名	SUB TITLE
WEIGHT	重量	CASE DEPT	場合深さ	品名	SUB TITLE
REMARKS	備考			3-F CODE	
表	APPD.	検図	CHK.	設計	DES.
		製図	DFT.	尺規	SCL.
		日付	DATE	09.08.24	
		3RD. ANG. PRO.	三角法		
		製	DWG. NO.	CS30-350B ENG	