

MV-CS060-10GM/GC

6 MP 1/1.8" CMOS GigE Area Scan Camera



GEN<i>i>CAM

GIG E
VISION

Introduction

With GigE interface, MV-CS060-10GM/GC camera adopts Sony® IMX178 sensor to provide high-quality images and transmit images in real time, and its max. frame rate can reach 19.1 fps in full resolution.

Key Feature

- Adopts brand new design to reduce power consumption.
- Supports multiple ISP functions like CCM to provide high-quality images.
- Compact design with mounting holes on panels for flexible mounting from 4 sides.
- Adopts GigE interface and max. transmission distance of 100 meters without relay.
- Compatible with GigE Vision V2.0 Protocol, GenlCam Standard, and third-party software based on the protocol and standard.

Dimension

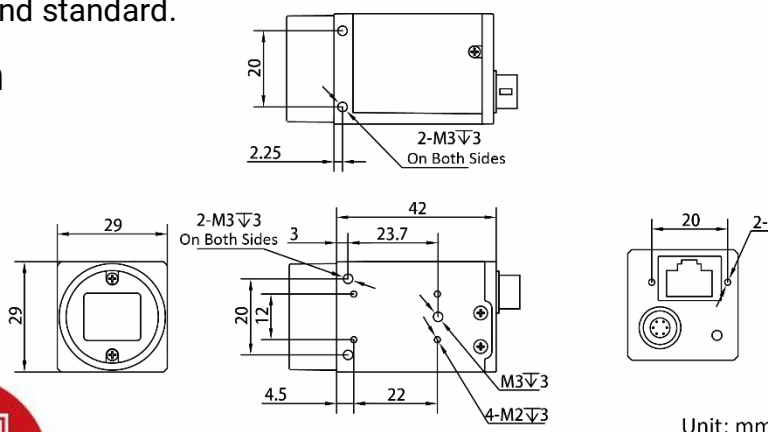

Available Model

- Mono camera: MV-CS060-10GM
- Color camera: MV-CS060-10GC

Applicable Industry

SMT/ PCB AOI, consumer electronics, electrical semiconductor, etc.

Sensor Quantum Efficiency

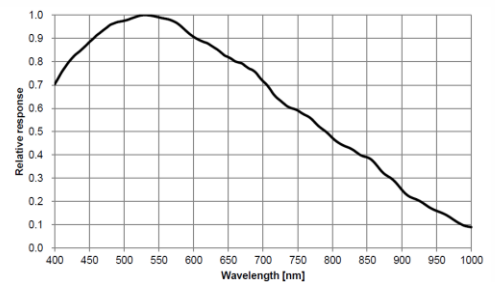

MV-CS060-10GM

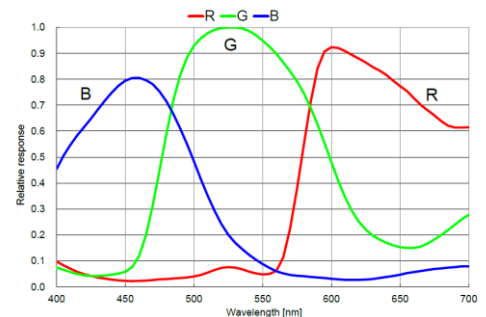

MV-CS060-10GC



Specification

Model	MV-CS060-10GM	MV-CS060-10GC
Camera		
Sensor type	CMOS, rolling shutter	
Sensor model	Sony® IMX178	
Pixel size	2.4 μm × 2.4 μm	
Sensor size	1/1.8"	
Resolution	3072 × 2048	
Max. frame rate	19.1 fps @3072 × 2048	
Dynamic range	71.3 dB	
SNR	41.3 dB	
Gain	0 dB to 24 dB	
Exposure time	25 μs to 2.5 sec	
Exposure mode	Off/Once/Continuous exposure mode, supports Global Reset, Trigger Rolling, and Rolling	
Mono/color	Mono	Color
Pixel format	Mono 8/10/10p/12/12p	Mono 8/10/12, Bayer RG 8/10/10p/12/12p, YUV422Packed, YUV422_YUYV_Packed, RGB 8, BGR 8
Binning	Supports 1 × 1, 2 × 2	
Decimation	Supports 1 × 1, 2 × 2, 4 × 4	
Reverse image	Supports horizontal and vertical reverse image output	
Electrical features		
Data interface	Gigabit Ethernet, compatible with Fast Ethernet	
Digital I/O	6-pin Hirose connector provides power and I/O, including opto-isolated input × 1 (Line 0), opto-isolated output × 1 (Line 1), bi-directional non-isolated I/O × 1 (Line 2).	
Power supply	9 VDC to 24 VDC, supports PoE	
Power consumption	Typ. 2.4 W@12 VDC	Typ. 2.5 W@12 VDC
Mechanical		
Lens mount	C-Mount	
Dimension	29 mm × 29 mm × 42 mm (1.1" × 1.1" × 1.2")	
Weight	Approx. 100 g (0.22 lb.)	
Ingress protection	IP40 (under proper lens installation and wiring)	
Temperature	Working temperature: -30 °C to 60 °C (-22 °F to 140 °F) Storage temperature: -30 °C to 70 °C (-22 °F to 158 °F)	
Humidity	20% to 95% RH, non-condensing	
General		
Client software	MVS or third-party software meeting with GigE Vision Protocol	
Operating system	32/64-bit Windows XP/7/10, 32/64-bit Linux and 64-bit MacOS	
Compatibility	GigE Vision V2.0, GenICam	
Certification	CE, RoHS, KC	



Hangzhou Hikrobot Co., Ltd.
 en.hikrobotics.com