

MV-CU050-30GM/GC

5 MP CMOS GigE Area Scan Camera



GEN*i*CAM

GiGE
VISION

Introduction

MV-CU050-30GM/GC camera adopts AR0521 sensor to provide high-quality images. It uses GigE interface to transmit non-compressed images in real time, and its max. frame rate can reach 24 fps in full resolution.

Key Feature

- Adopts low power consumption design with stable performance.
- Supports auto and manual adjustment of gain, exposure time, etc.
- Supports hardware trigger, software trigger, free run, etc.
- Adopts GigE interface and max. transmission distance of 100 meters without relay.
- Compatible with GigE Vision V2.0 Protocol, GenICam Standard, and third-party software based on the protocol and standard.

Dimension

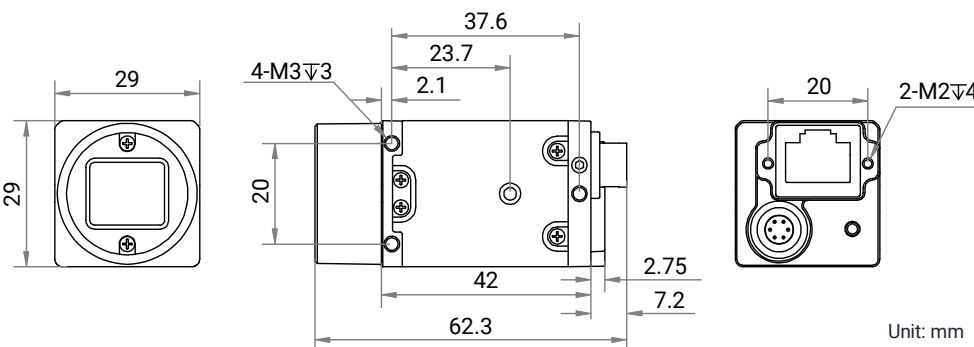

Available Model

- Mono camera: MV-CU050-30GM
- Color camera: MV-CU050-30GC

Applicable Industry

Electronics and semiconductor, factory automation, logistics and code reading, medicine package, etc.

Sensor Quantum Efficiency

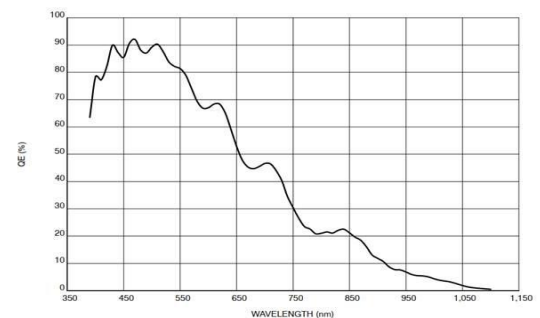

MV-CU050-30GM

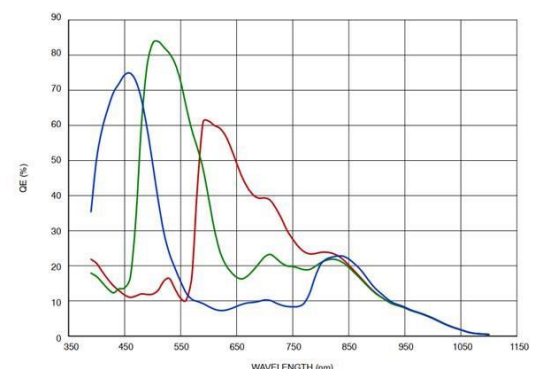

MV-CU050-30GC

Specification

Model	MV-CU050-30GM	MV-CU050-30GC
Performance		
Sensor type	CMOS, rolling shutter	
Sensor model	AR0521	
Pixel size	2.2 μm \times 2.2 μm	
Sensor size	1/2.5"	
Resolution	2592 \times 1944	
Max. frame rate	24 fps @ 2592 \times 1944 Mono 8	24 fps @ 2592 \times 1944 Bayer GR 8
Dynamic range	63 dB	
SNR	37 dB	
Gain	0 dB to 15 dB	
Exposure time	21 μs to 1 sec	
Exposure mode	Off/Once/Continuous exposure mode	
Mono/color	Mono	Color
Pixel format	Mono 8/10/10Packed/12/12Packed	Bayer GR 8/10/10Packed/12/12Packed
Binning	Supports 1 \times 1, 2 \times 2	
Decimation	Supports 1 \times 1, 2 \times 2	
Reverse image	Supports horizontal and vertical reverse image output	
Electrical features		
Data interface	Gigabit Ethernet (1000 Mbit/s), compatible with Fast Ethernet (100 Mbit/s)	
Digital I/O	6-pin P7 connector provides power and I/O, including opto-isolated input \times 1 (Line 0), opto-isolated output \times 1 (Line 1), bi-directional non-isolated I/O \times 1 (Line 2).	
Power supply	9 VDC to 24 VDC, supports PoE	
Power consumption	Typ. 1.78 W @ 12 VDC	Typ. 1.81 W @ 12 VDC
Mechanical		
Lens mount	C-mount	
Dimension	29 mm \times 29 mm \times 42 mm (1.1" \times 1.1" \times 1.7")	
Weight	Approx. 100 g (0.2 lb.)	
Ingress protection	IP30 (under proper lens installation and wiring)	
Temperature	Working temperature: 0 $^{\circ}\text{C}$ to 50 $^{\circ}\text{C}$ (32 $^{\circ}\text{F}$ to 122 $^{\circ}\text{F}$) Storage temperature: -30 $^{\circ}\text{C}$ to 80 $^{\circ}\text{C}$ (-22 $^{\circ}\text{F}$ to 176 $^{\circ}\text{F}$)	
Humidity	20% RH to 80% RH (no condensation)	
General		
Client software	MVS or third-party software meeting with GigE Vision Protocol	
Operating system	32/64-bit Windows XP/7/10/11, 32/64-bit Linux, and 64-bit MacOS	
Compatibility	GigE Vision V2.0, GenICam	
Certification	RoHS	